

1987 System Wiring Diagrams
Ford - Taurus

PAVLIN

Fig. 1: Cooling Fan Circuit
1987 Ford Taurus LX

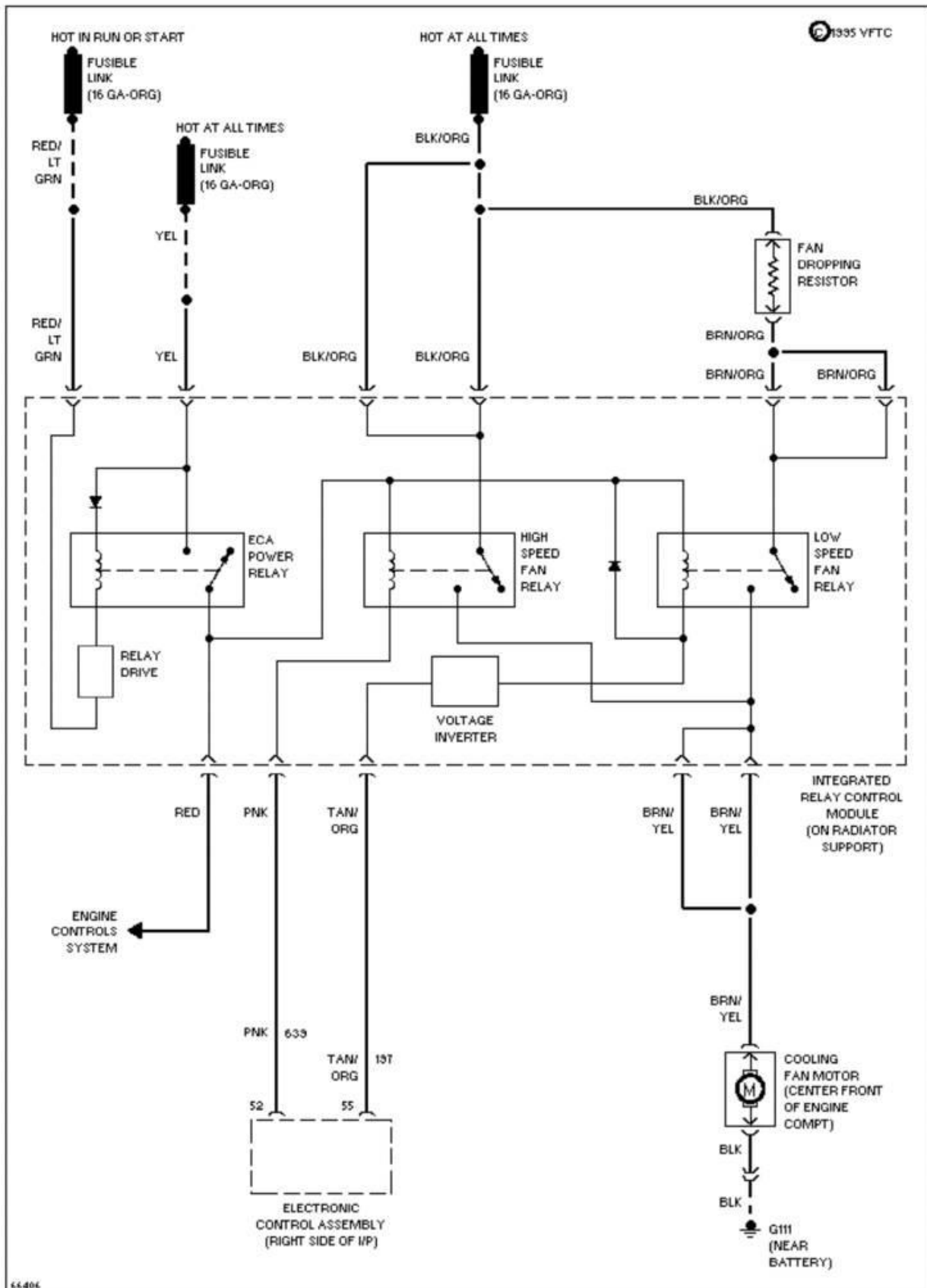

66406

1987 System Wiring Diagrams
Ford - Taurus

PAVLIN

Fig. 2: Defogger Circuit
1987 Ford Taurus LX

© 1995 VFTC

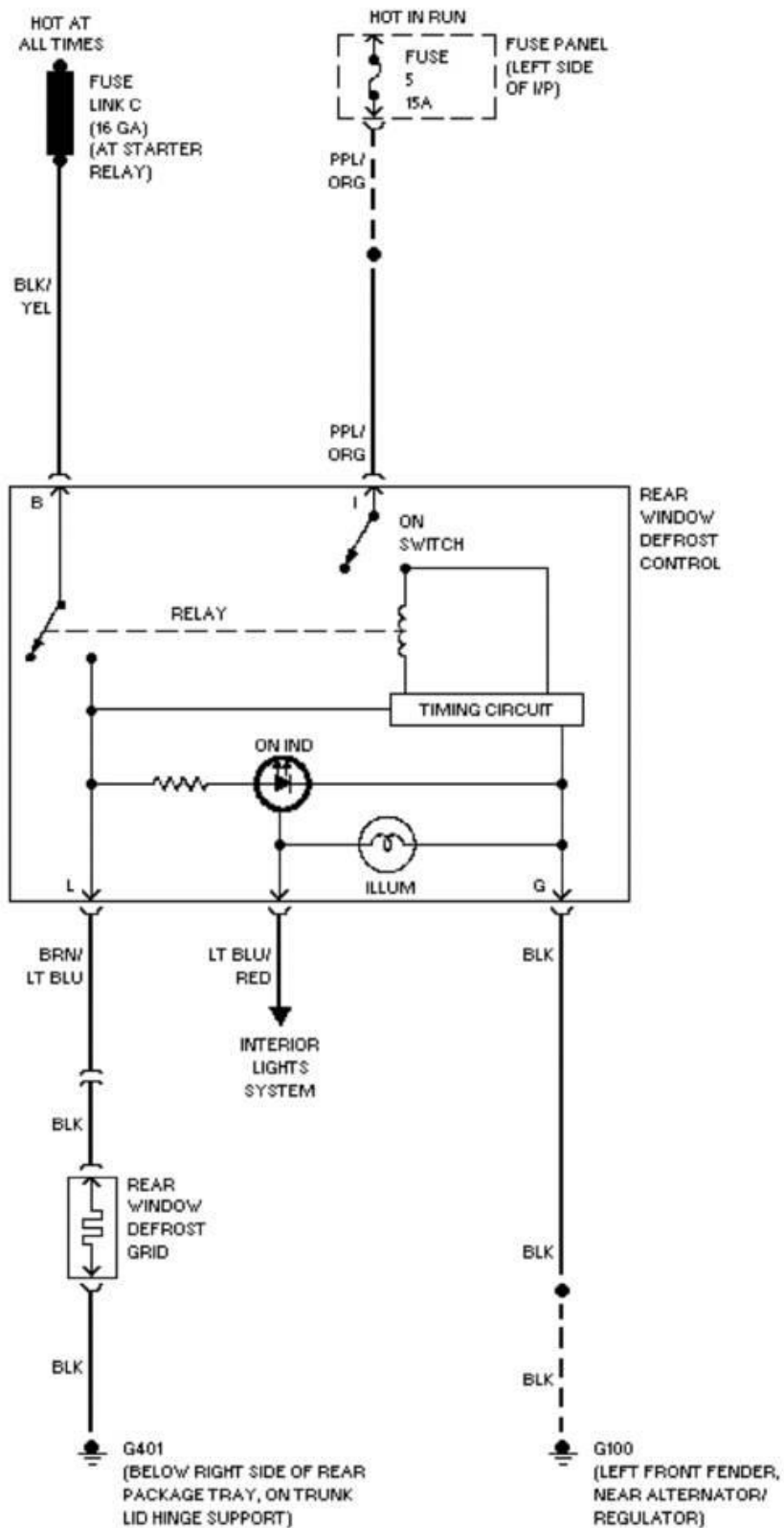

6.96.20

1987 System Wiring Diagrams
Ford - Taurus

PAVLIN

Fig. 3: Horn Circuit
1987 Ford Taurus LX

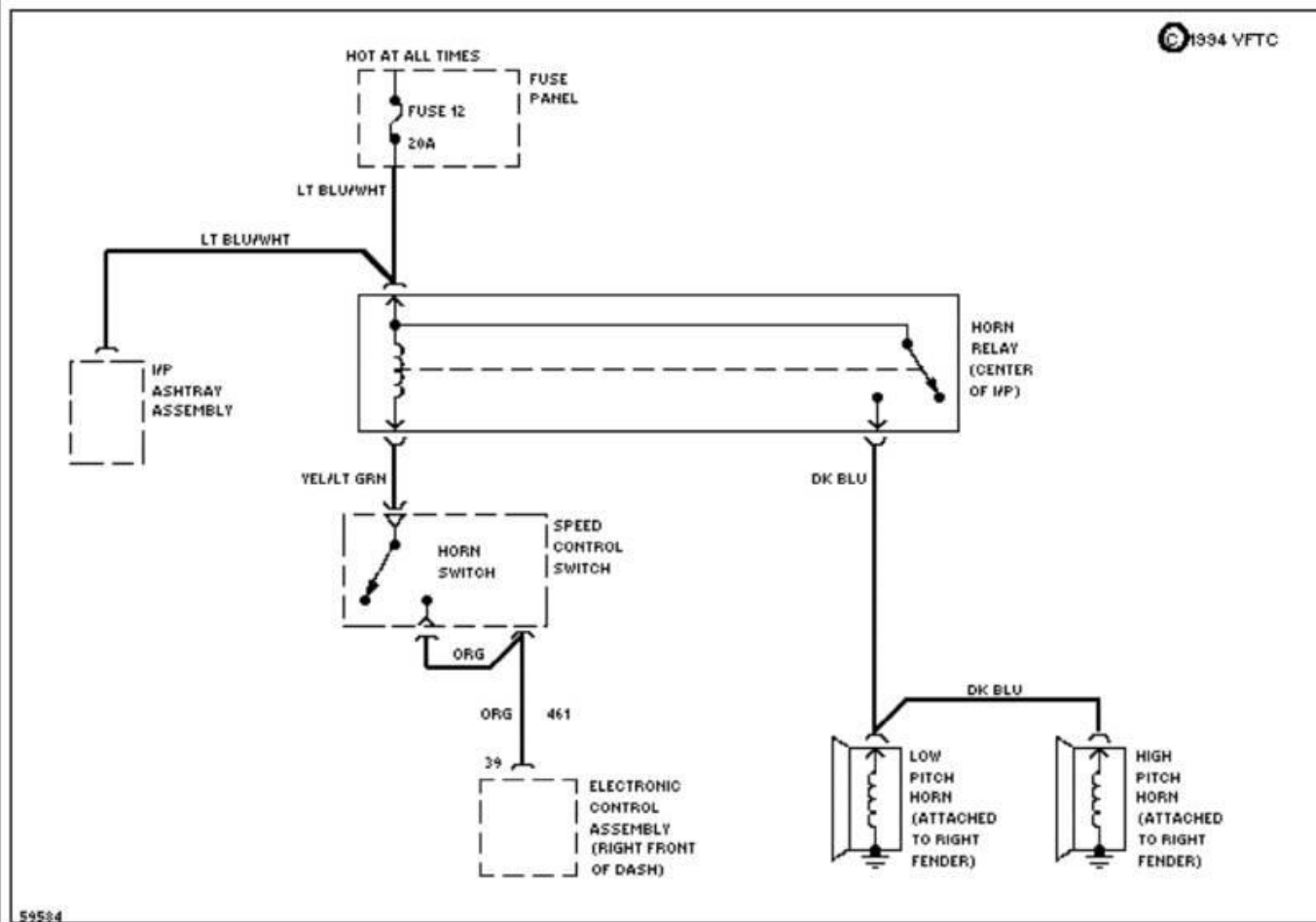

1987 System Wiring Diagrams
Ford - Taurus

PAVLIN

Fig. 4: Power Antenna Circuit
1987 Ford Taurus LX

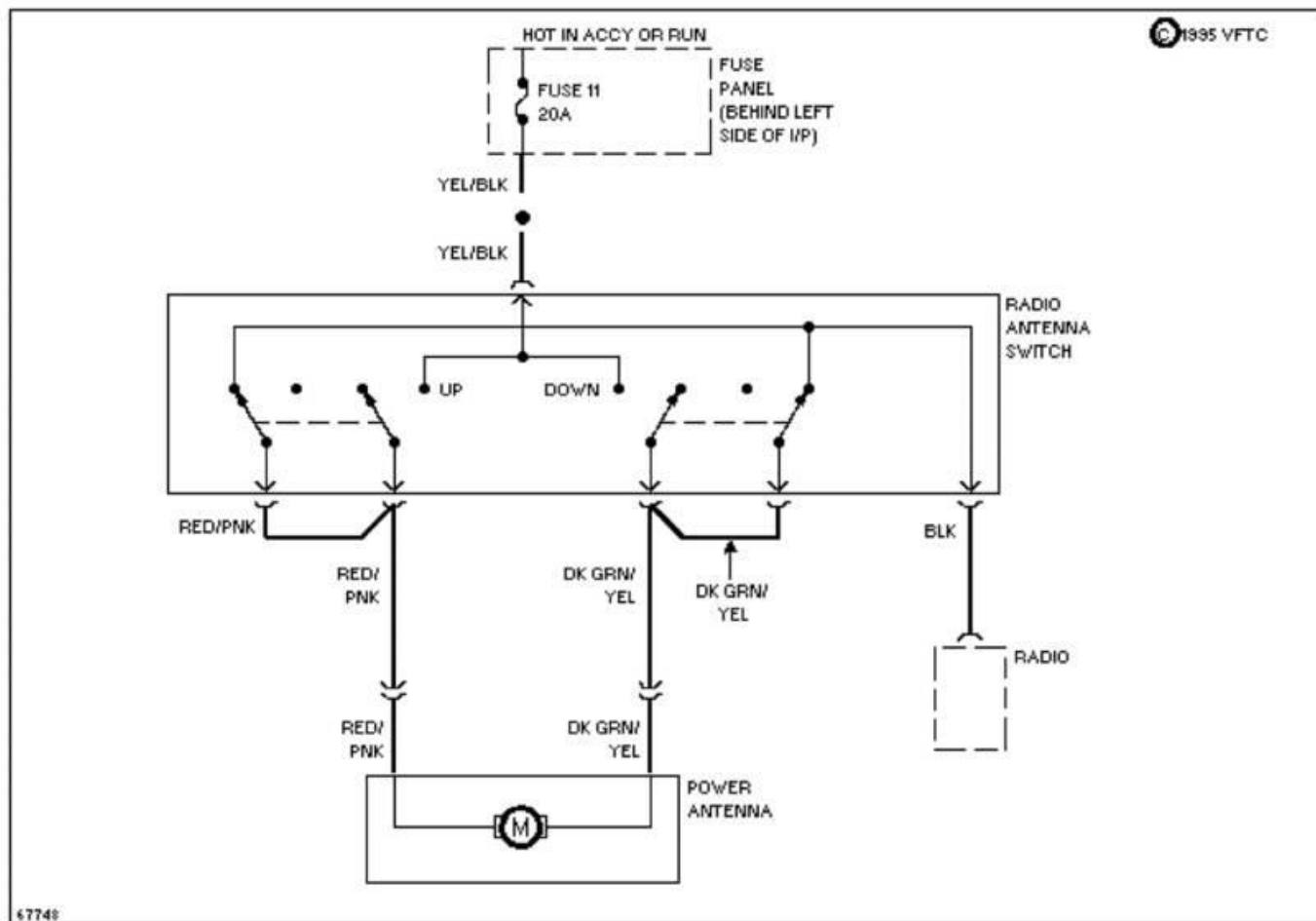

1987 System Wiring Diagrams
Ford - Taurus

PAVLIN

Fig. 5: Power Door Lock Circuit
1987 Ford Taurus LX

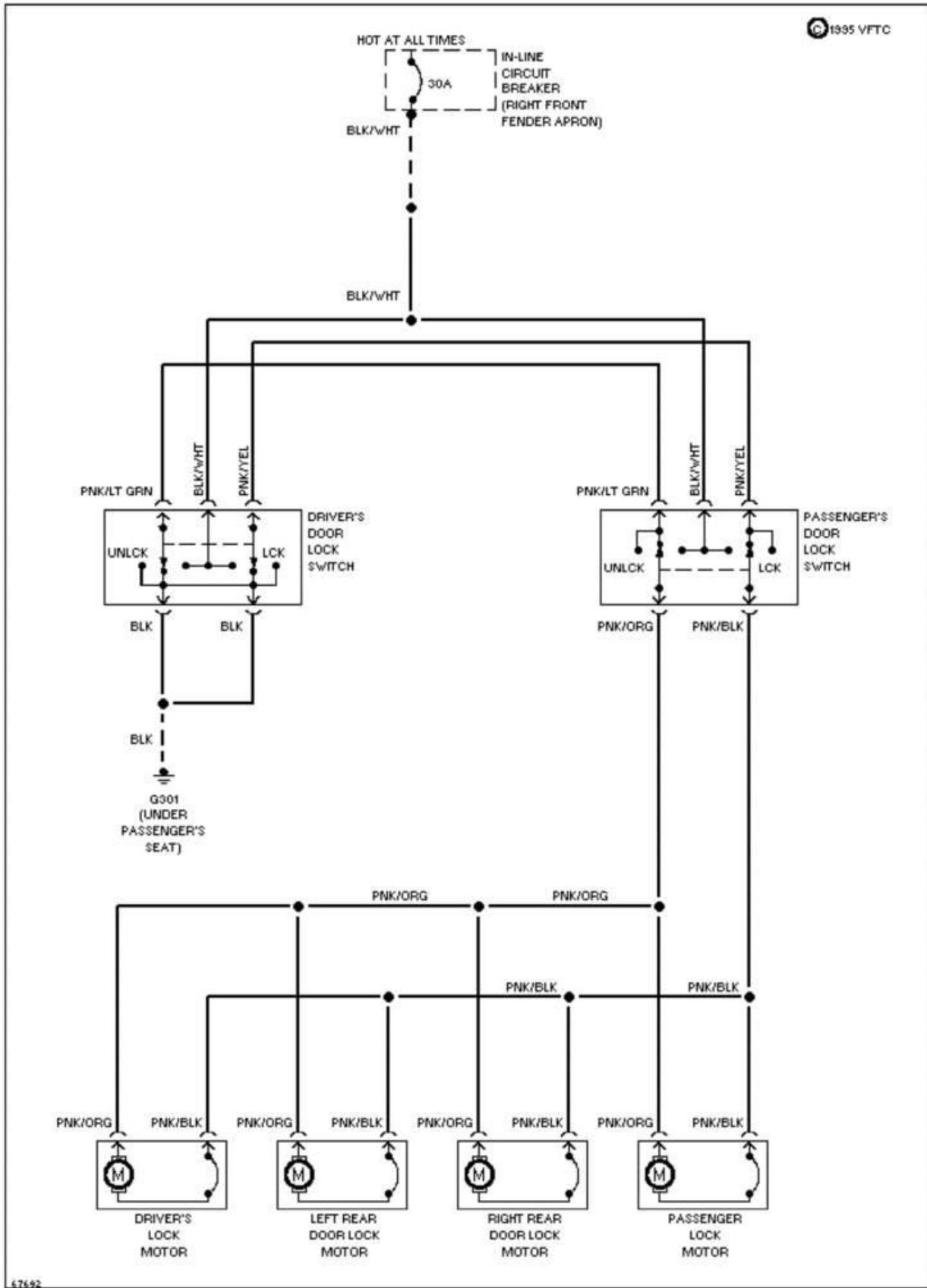

1987 System Wiring Diagrams
Ford - Taurus

PAVLIN

Fig. 6: Power Mirror Circuit
1987 Ford Taurus LX

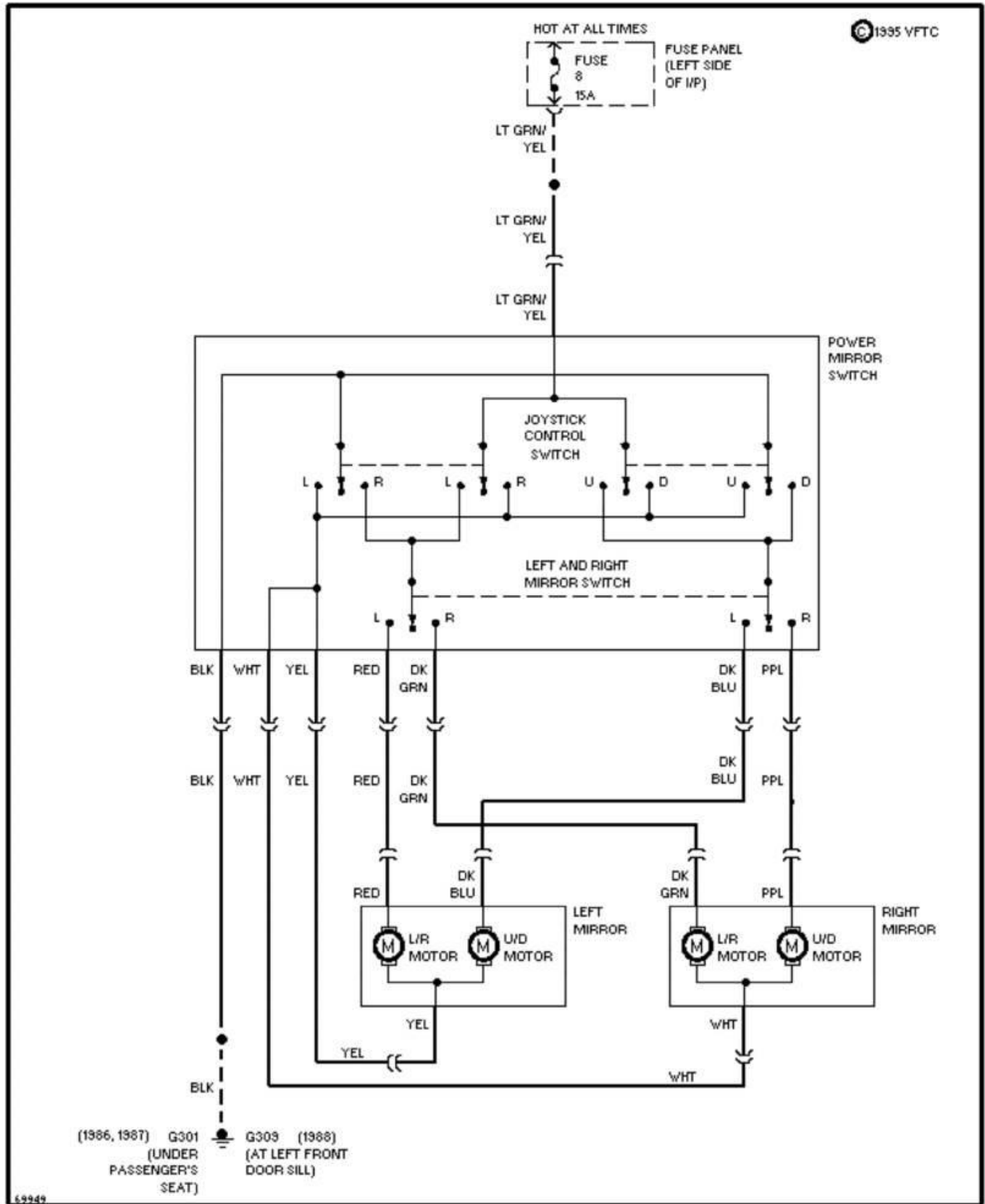

1987 System Wiring Diagrams
Ford - Taurus

PAVLIN

Fig. 7: Lumbar Circuit
1987 Ford Taurus LX

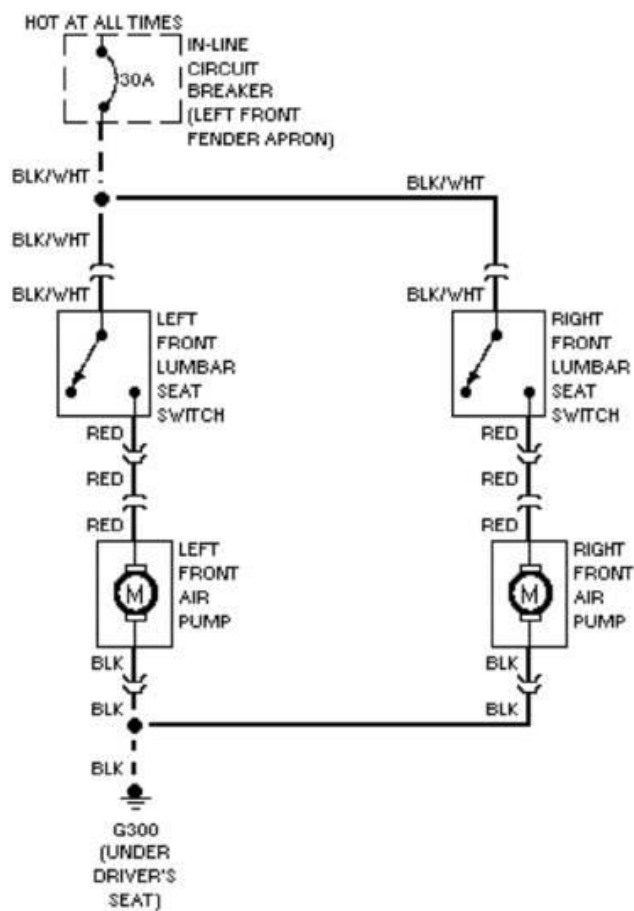

66511

1987 System Wiring Diagrams
Ford - Taurus

PAVLIN

Fig. 8: Power Seat Circuit
1987 Ford Taurus LX

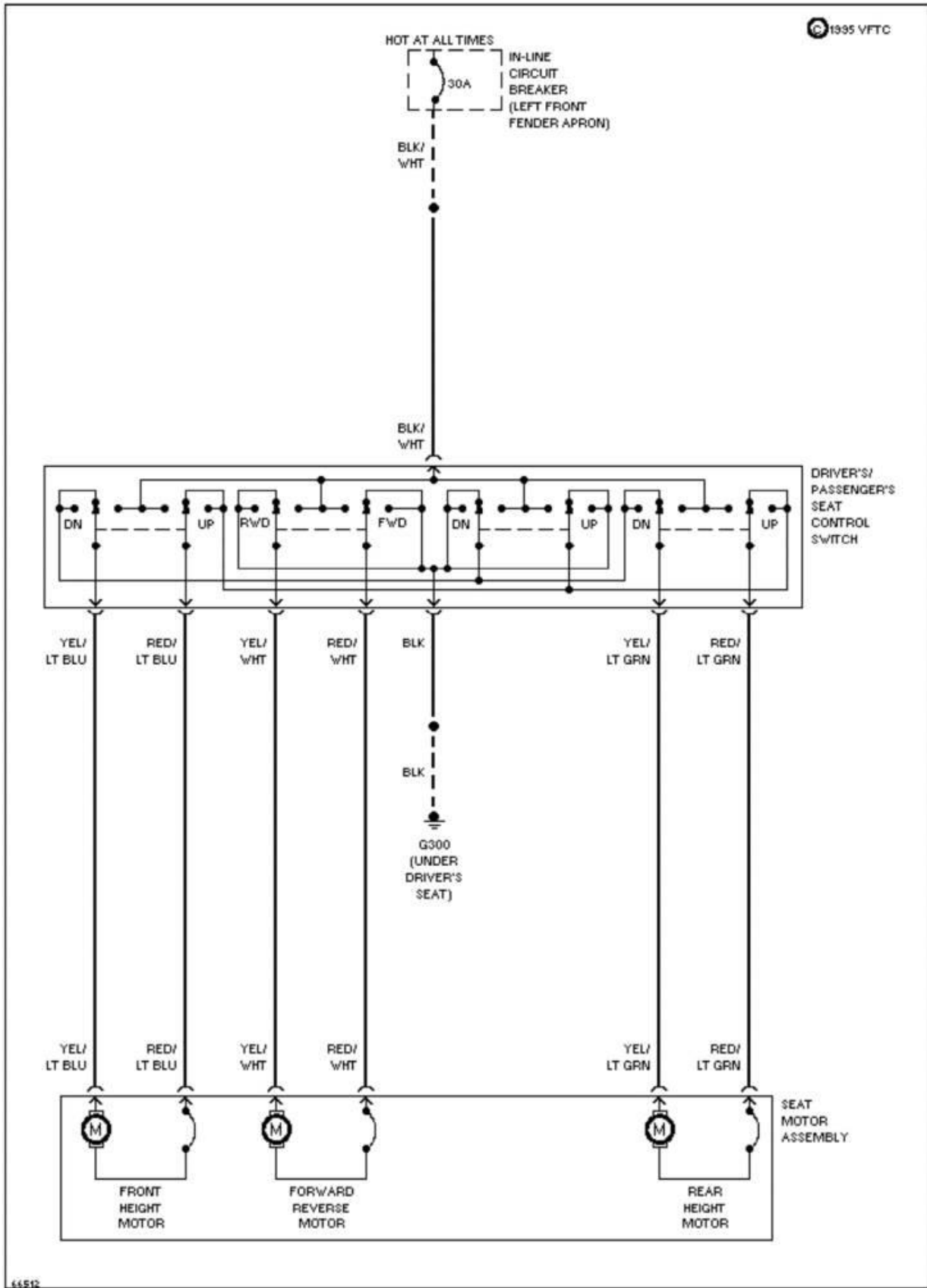

1987 System Wiring Diagrams Ford - Taurus

PAVLIN

Fig. 9: Power Window Circuit
1987 Ford Taurus LX

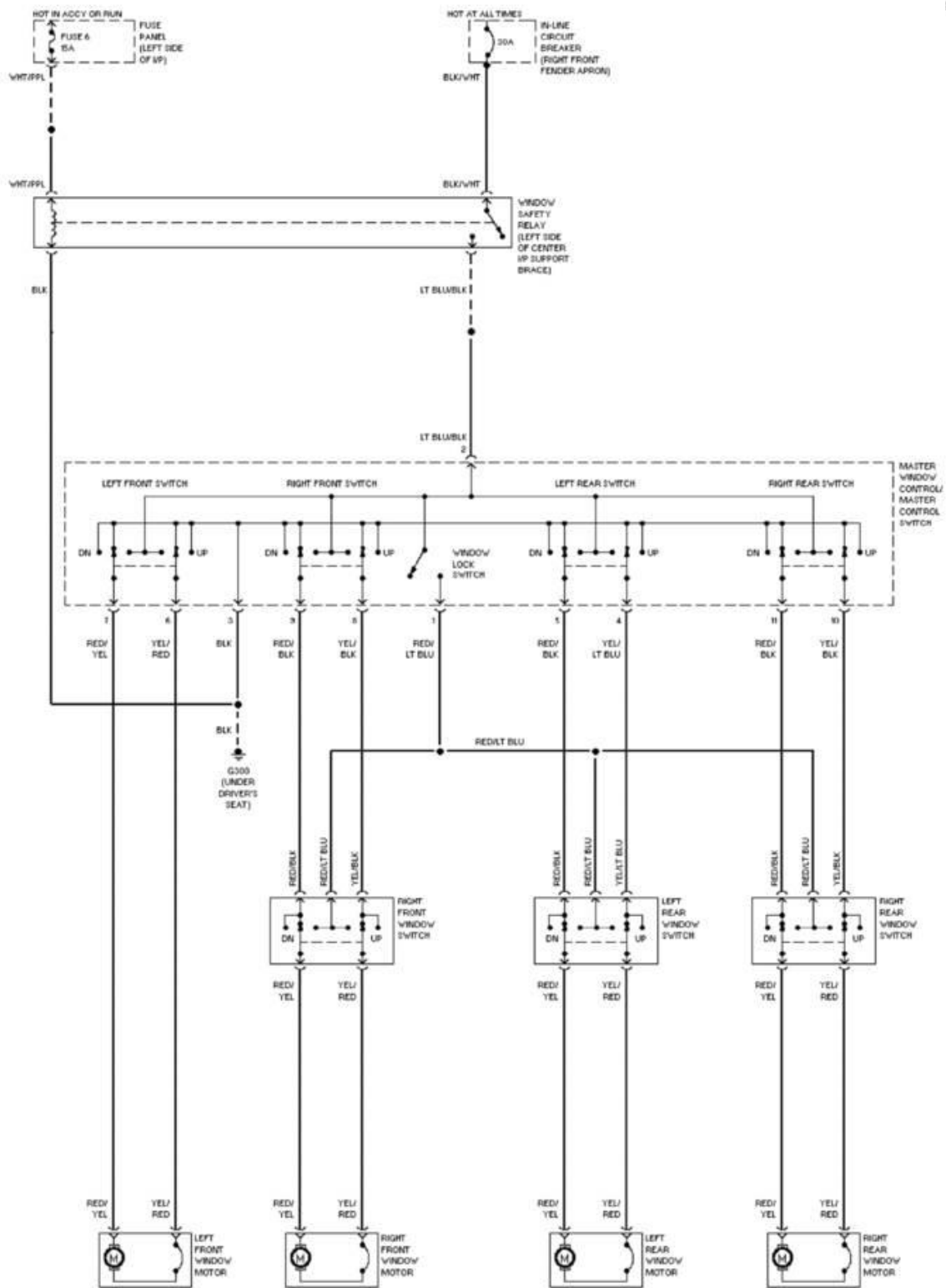

1987 System Wiring Diagrams
Ford - Taurus

PAVLIN

Fig. 10: Radio Circuits
1987 Ford Taurus LX

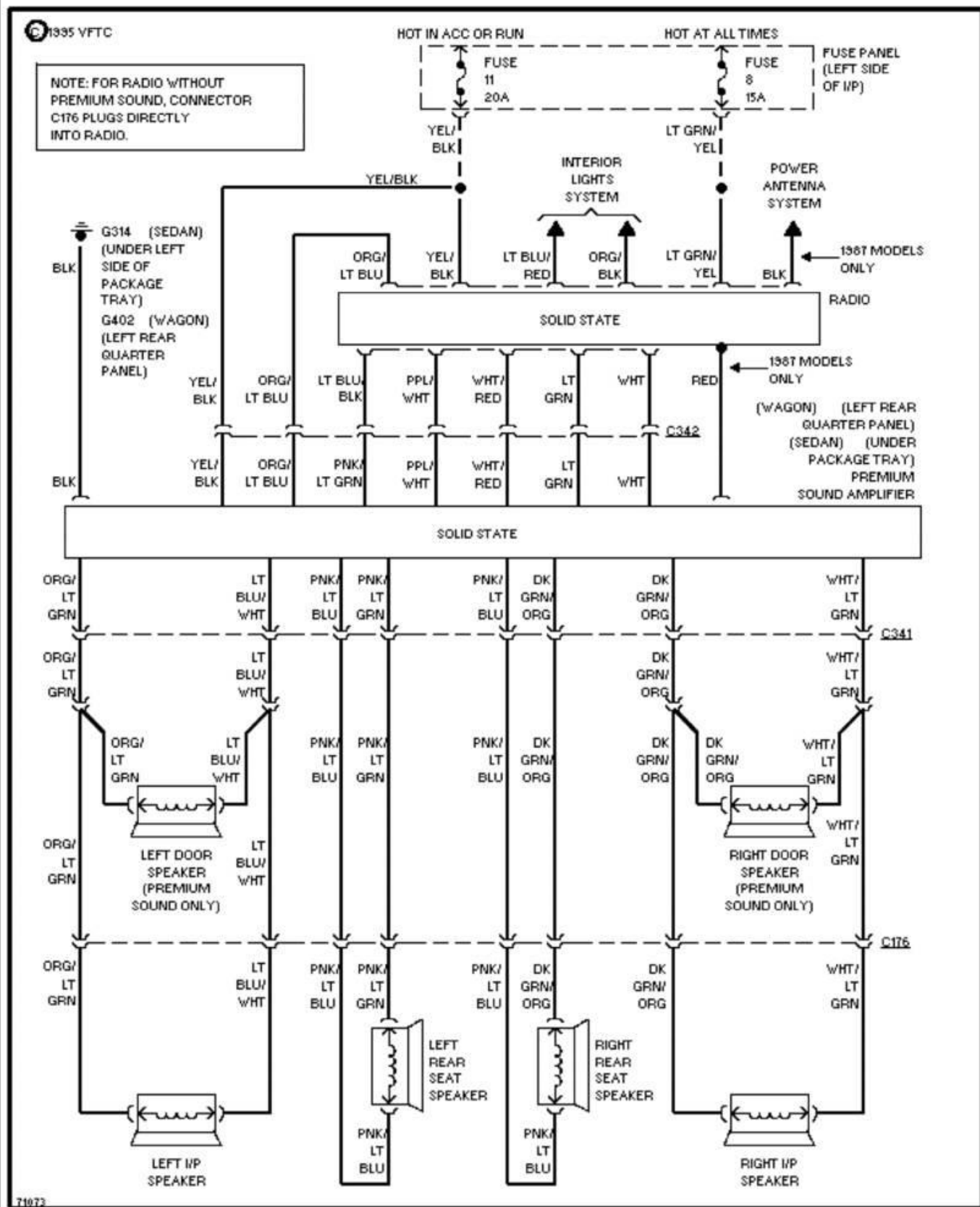

1987 System Wiring Diagrams
Ford - Taurus

PAVLIN

Fig. 11: 2.5L, Charging Circuit
1987 Ford Taurus LX

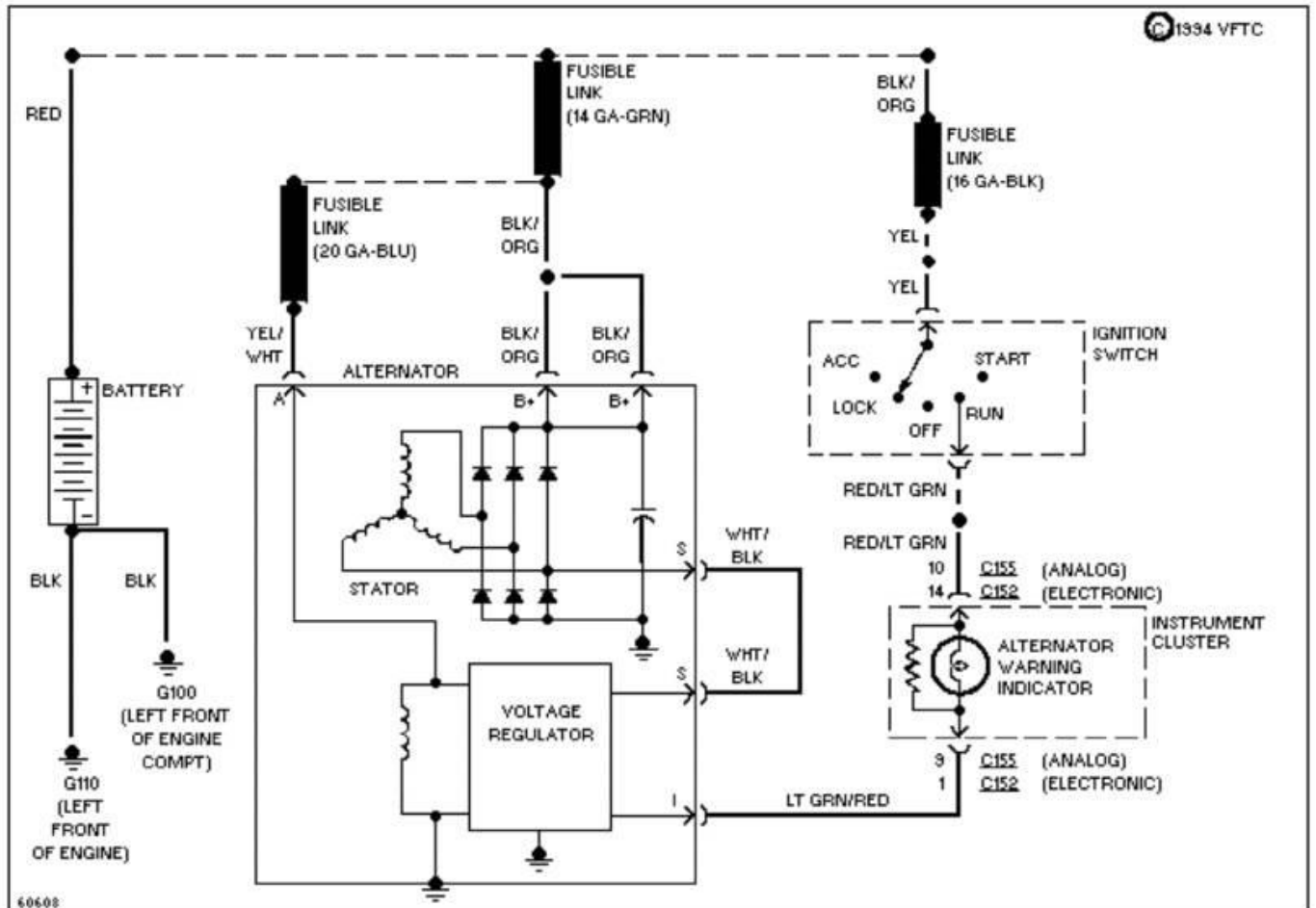

1987 System Wiring Diagrams
Ford - Taurus

PAVLIN

Fig. 12: Starting Circuit
1987 Ford Taurus LX

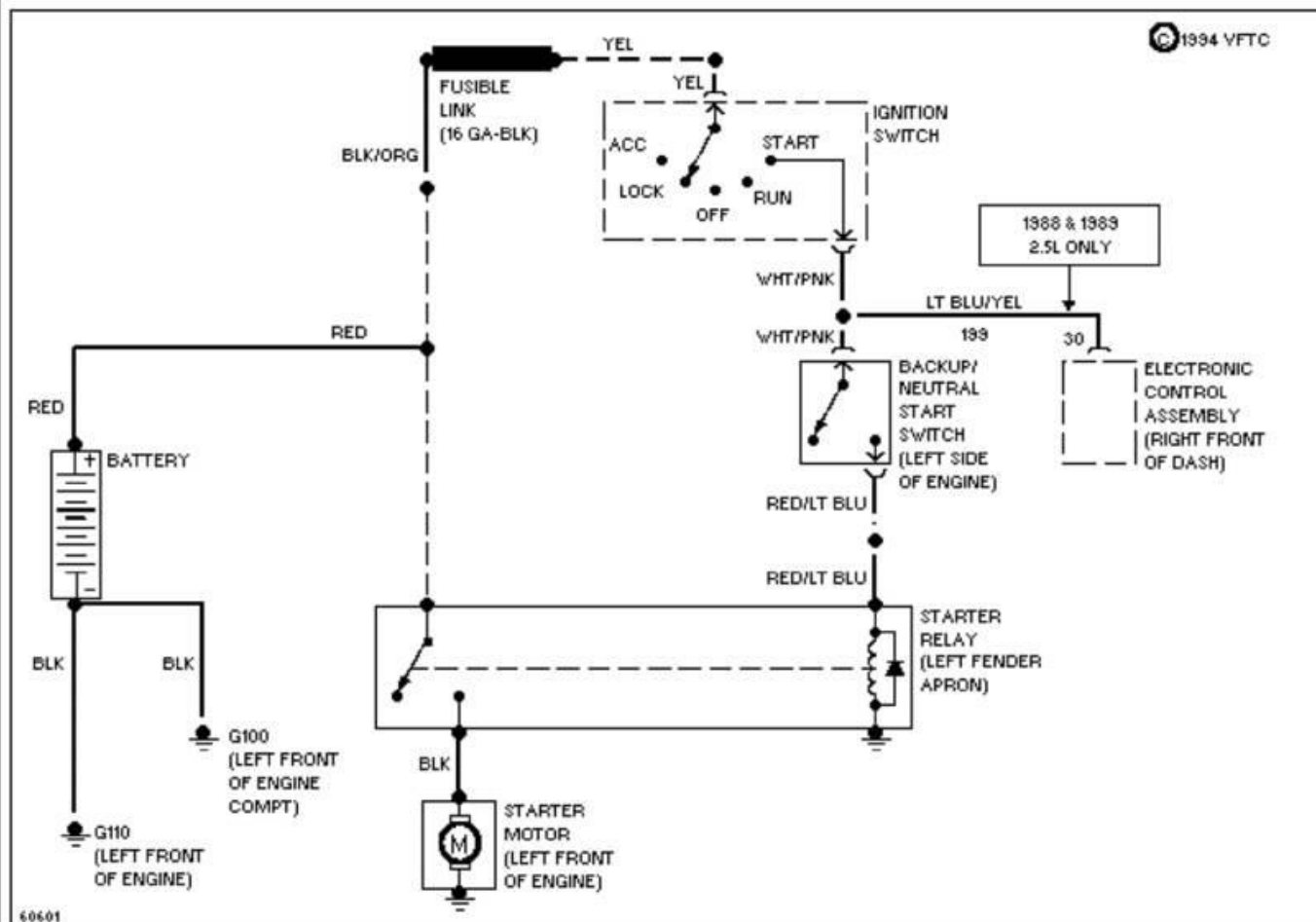

1987 System Wiring Diagrams
Ford - Taurus

PAVLIN

Fig. 13: 3.0L, Charging Circuit, W/ Heated Windshield
1987 Ford Taurus LX

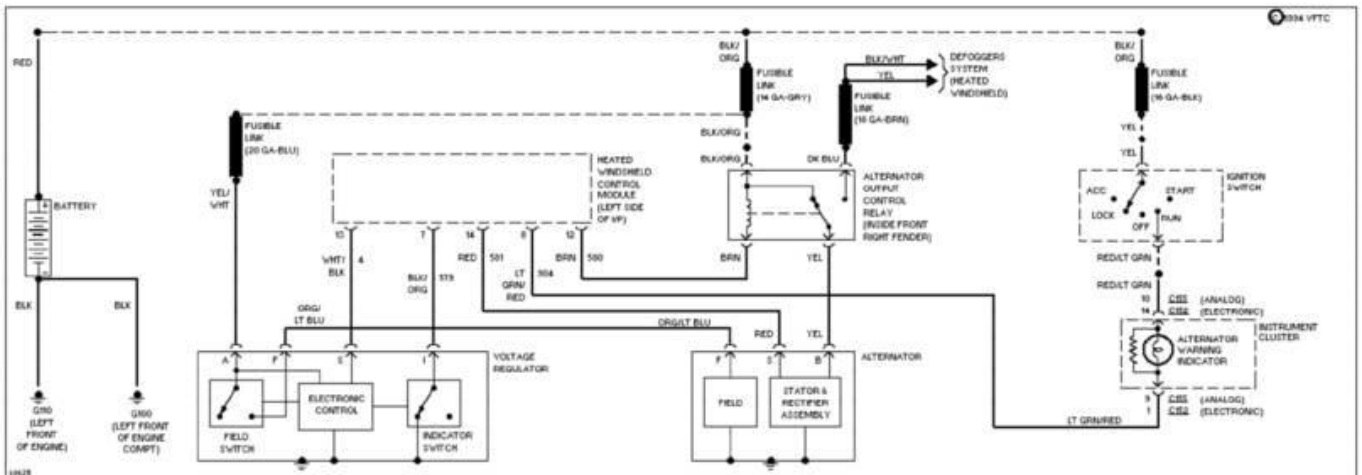

1987 System Wiring Diagrams
Ford - Taurus

PAVLIN

Fig. 14: 3.0L, Charging Circuit, W/O Heated Windshield
1987 Ford Taurus LX

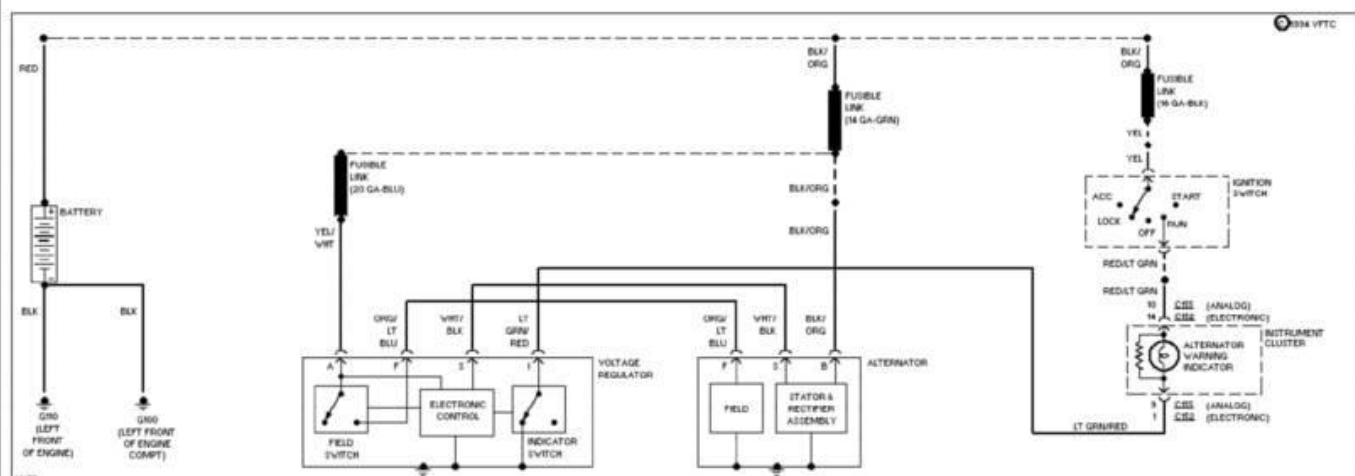

1987 System Wiring Diagrams
Ford - Taurus

PAVLIN

Fig. 15: Starting Circuit
1987 Ford Taurus LX

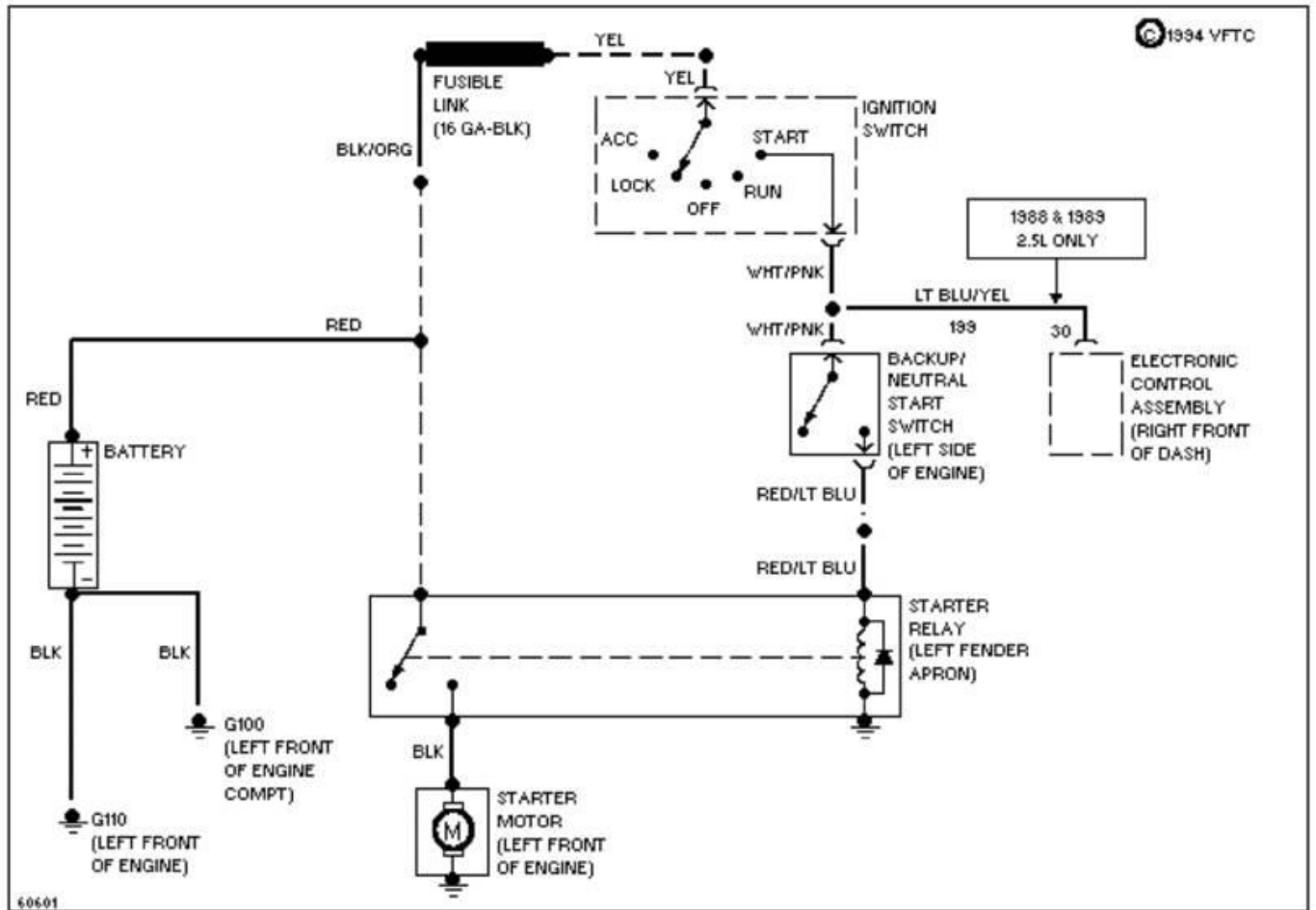

1987 System Wiring Diagrams
Ford - Taurus

PAVLIN

Fig. 16: 2-Speed Wiper/Washer Circuit
1987 Ford Taurus LX

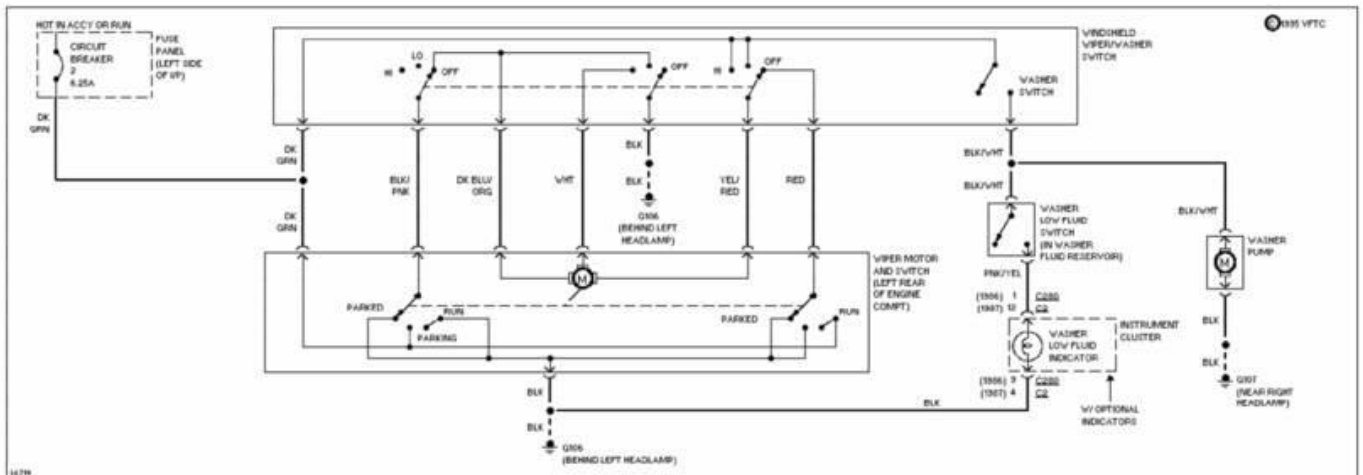

1987 System Wiring Diagrams
Ford - Taurus

PAVLIN

Fig. 17: Interval Wiper/Washer Circuit
1987 Ford Taurus LX

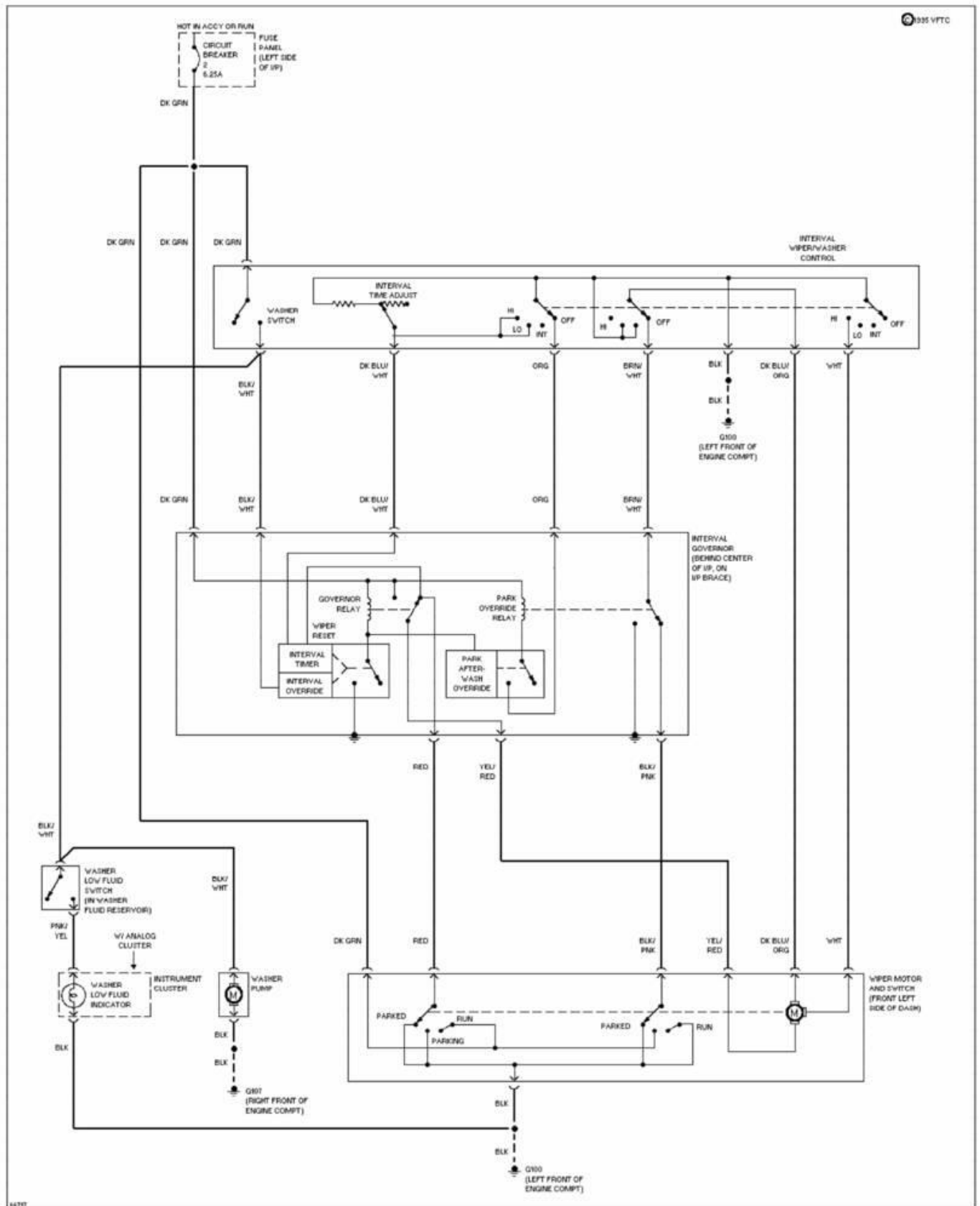

1987 System Wiring Diagrams
Ford - Taurus

PAVLIN

Fig. 18: Rear Wiper/Washer Circuit
1987 Ford Taurus LX

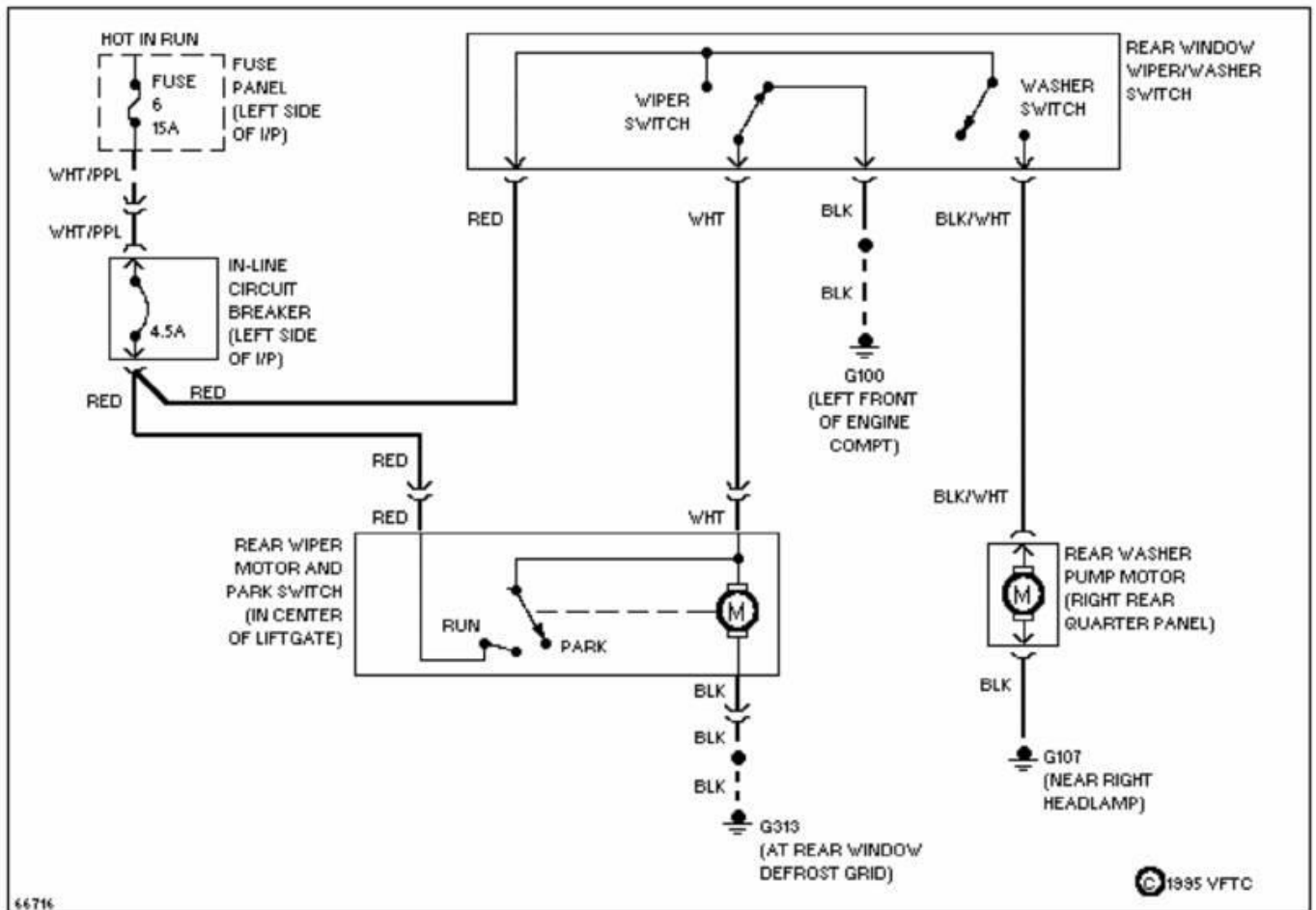

WIRING DIAGRAMS

1987 Wiring Diagrams Ford Motor Co.

PAVLIN

Fig. 1: Engine Compartment
1987 Ford Taurus LX

COMPONENT LOCATOR:

A/C CLUTCH CYCLE	PRES SW	C 29, B 30
A/C COMP CLUTCH		B 4, B 9
A/C SEL SW (MANUAL)		B 28
ALTERNATOR		D 4, F 4
ALT OUTPUT CTRL RLY		F 3
AUTO LAMP RLYS		B-C 23
AUTO LAMP TIME CTRL SW		A-B 28
BACK-UP LTS		D 48
BATTERY		A 2
BLOWER MTR		A 32
CIG LTR		D 26, A 33
CLOCK		A 33
COURTESY/DOME LTS		A-C 43-45
CRUISE CTRL SERVO		A 14
CRUISE CTRL SWS		B 33
DEFOGGER SWITCH		C-D 33
DIAG WARN MOD		A 19, C 19, E 19
DOOR AJAR SWS		A-B 48
DOOR SWITCHES		A 42-44
DUAL BRAKE WARN SW		B 18
EATC CTRL HEAD		A 30-32
ELECT CTRL ASSY (2.0L)		A-E 8-9
ELECT CTRL ASSY (3.0L)		A-E 13
ELECT FLASHER		D 16
ENG COMPT LT		F 2
FRONT DOOR CTSY LTS		C 43
FUEL PUMP		E 5, E 10
FUSE BLOCK		C 16
GLOVE COMPT LT		D 46
GEAR SEL SWITCH		B 18
HEATED W/SHIELD CTRL		
MODULE		E-F 27
HEATER SEL SW		A 28-29
HI-LEVEL STOP LTS		E-F 48
HORN RLY		D 17
IGN COIL		C 4
IGN KEY WARN SW		F 14, F 17
IGN MODULE		B 4
IGN SWITCH		A 16-18
ILLUM ENTRY TIMER		A-B 46
INST CLUSTERS		A-F 34-37
INST ILLUM LT		B-O 25-27
INST PNL DIMMER SW		A 26
INTEGRATED CTRLLR		
MODULE		B-E 5, B-E 9
INTERVAL GOVERNOR		F 29-30
KEYLESS ENTRY MOD		E-F 42-43
LCD DIMMING RLY		C 23
LEFT FRNT DOOR SW		A 43
LICENSE LTS		D 48
LIGHT SWITCH		A 25
LT SENSOR AMP		A 27
LOW OIL LEVEL RLY		D 14
LOW WSRH FLUID SW		D 34, C 36
LUMBAR SEATS		A 41
MOON ROOF		A-C 42
MULTI-FUNCTION SW		D 32
O ₂ SENSOR		F 6, F 11
PARK BRAKE SW		B 18
PWR ANTENNA SW		B 40-41
PWR DOOR LOCKS		D-F 38-39
PWR MIRROR SW		B-C 38
PWR SEAT SW		A-B 38-39
PWR WDOOS		D-E 40-42
RADIO		D 23
RADIO NOISE CAP		C 3
REAR WIPER CIRC BRKR		F 40
SEAT BELT SW		F 15, F 16
SPEED SENSOR		A 7-A 12
STARTER CIRC BRKR		A 3
STARTER FUS LINKS		A-B 2-3
STARTER RLY		A 3
STOP LT SW		E 31, F 31, F 32
UPSHIFT DIMMER RLY		E 14
VOLT REGULATOR		E 4
WARN BUZZER		F 14
WARN CHIME		F 15
WASHER MTR		D 2
WDO SAFETY RLY		A 40-41
WIPER MTR		C 2
WIPER/WASHER SW		E 29, F 29

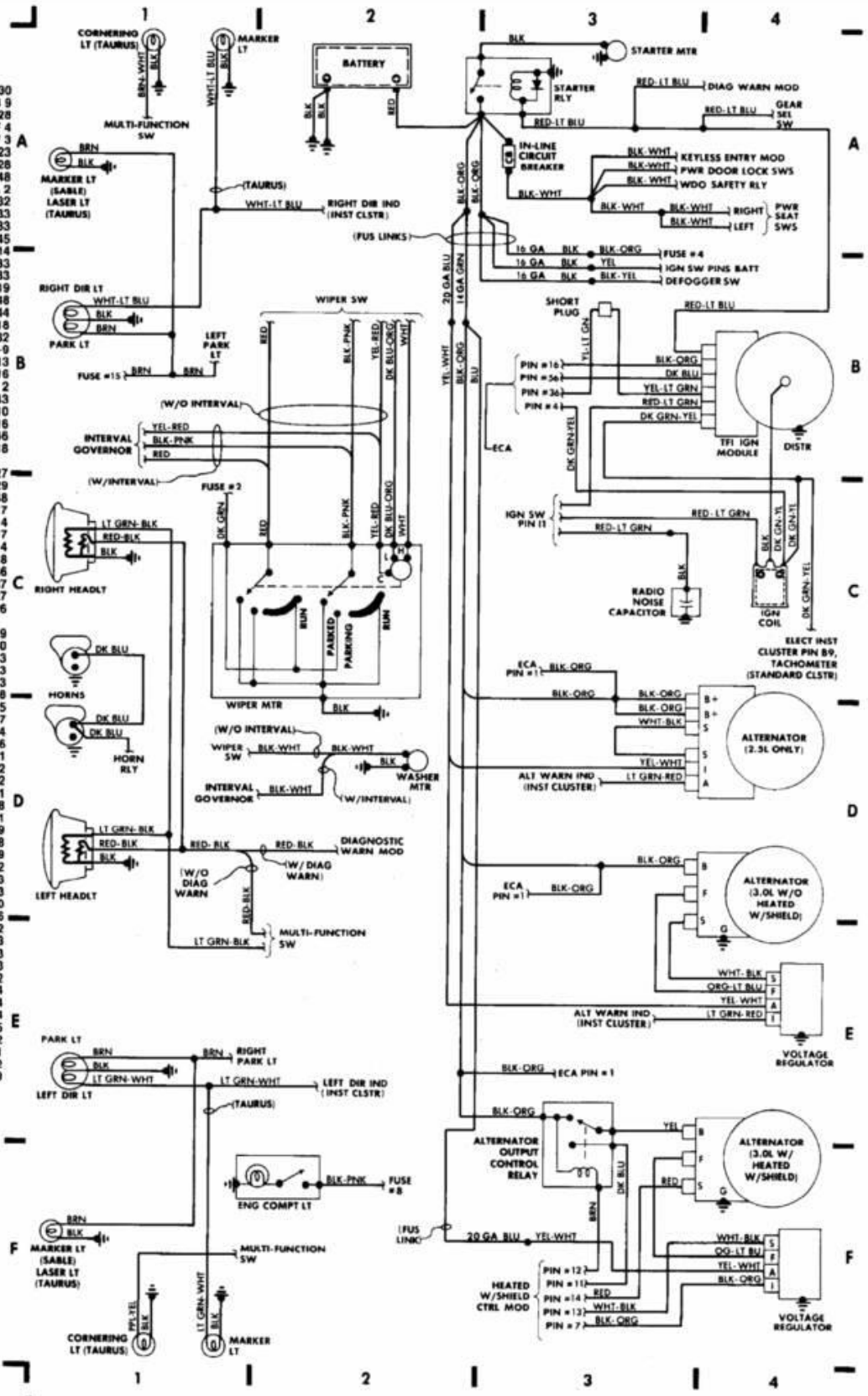

ENGINE COMPARTMENT

97968

WIRING DIAGRAMS

1987 Wiring Diagrams Ford Motor Co.

PAVLIN

Fig. 2: Engine Compartment (Cont.)
1987 Ford Taurus LX

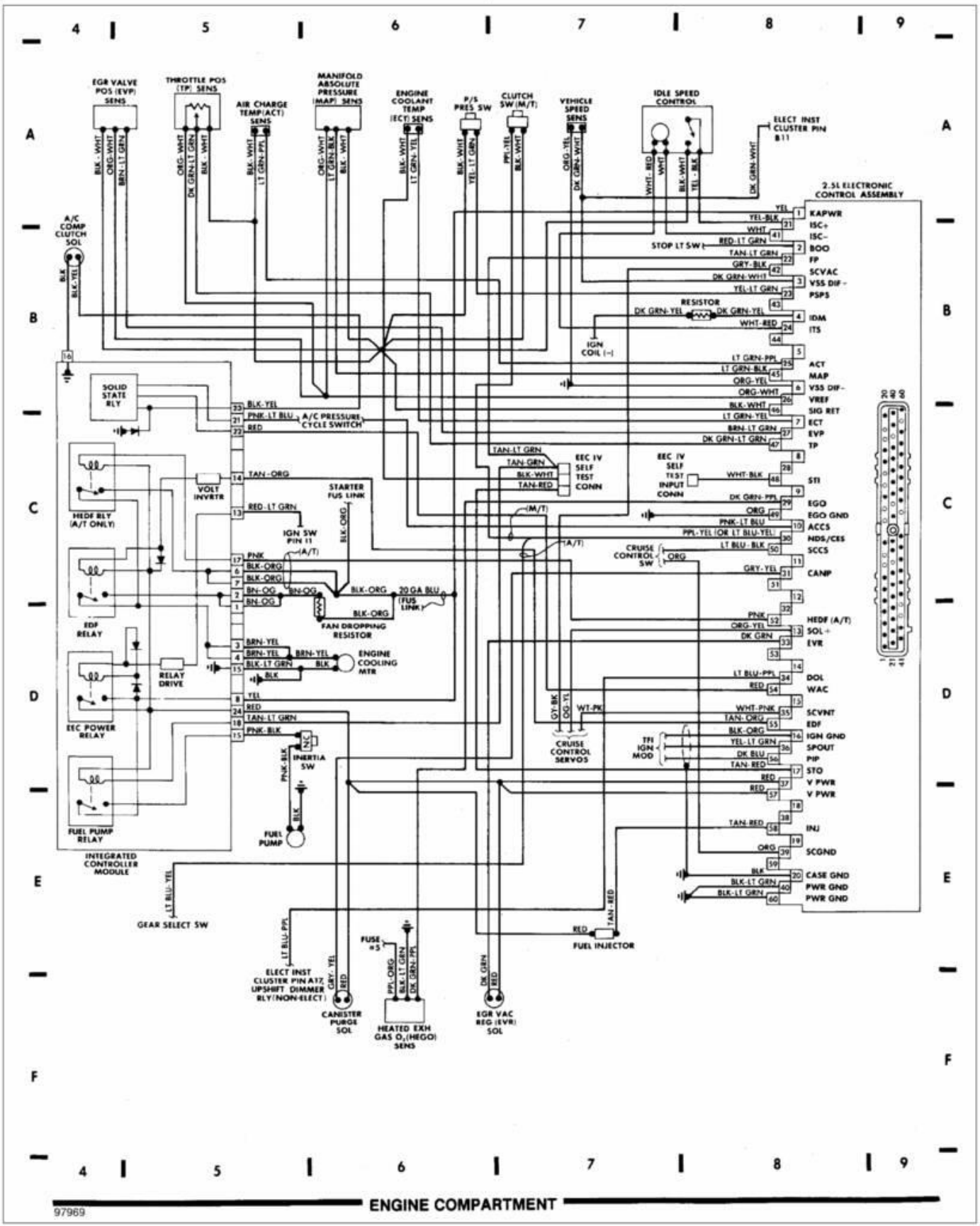

97969

ENGINE COMPARTMENT

WIRING DIAGRAMS
1987 Wiring Diagrams Ford Motor Co.

PAVLIN

Fig. 3: Engine Compartment (Cont.)
1987 Ford Taurus LX

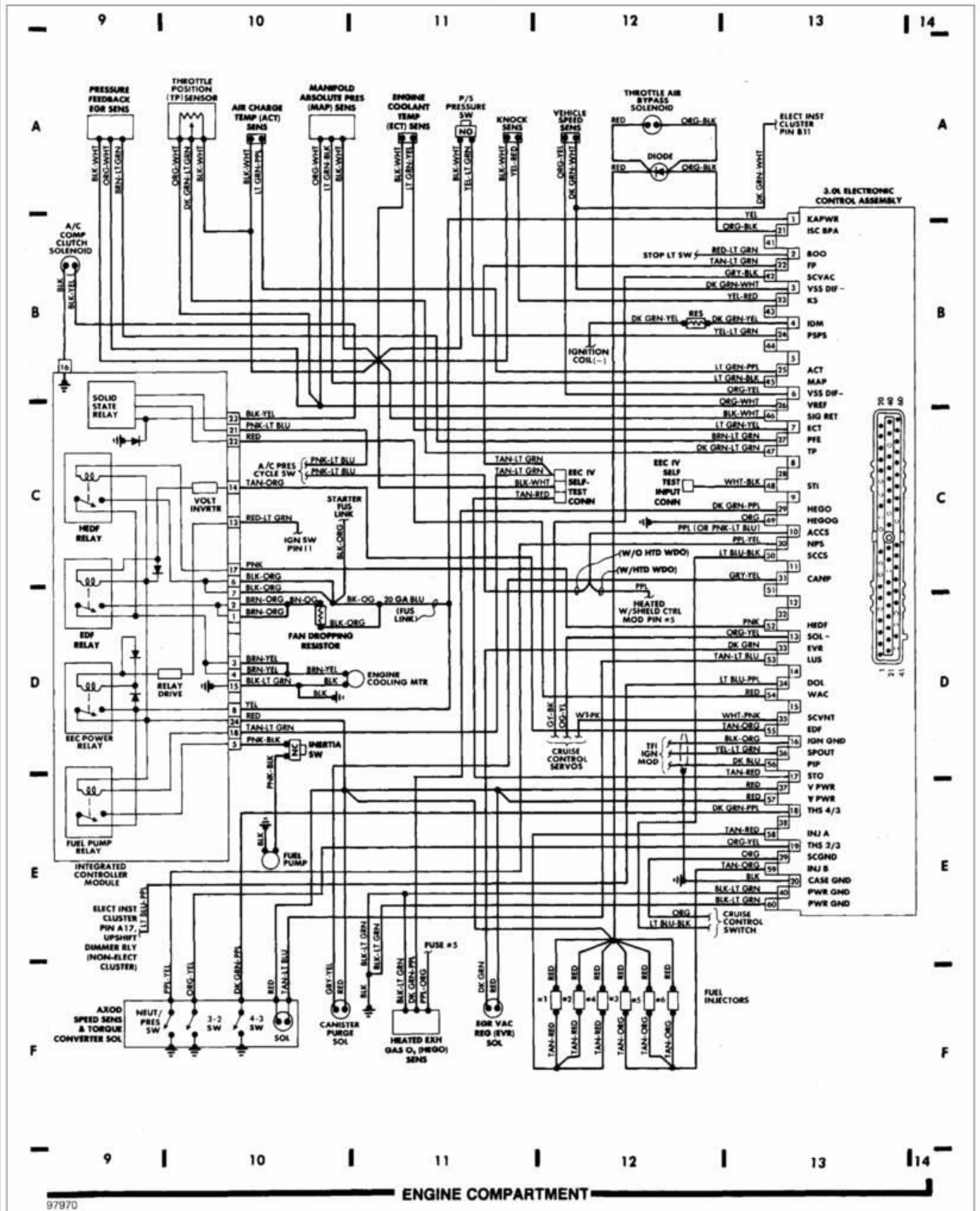

WIRING DIAGRAMS

1987 Wiring Diagrams Ford Motor Co.

PAVLIN

Fig. 4: Fuse Block & Underdash
1987 Ford Taurus LX

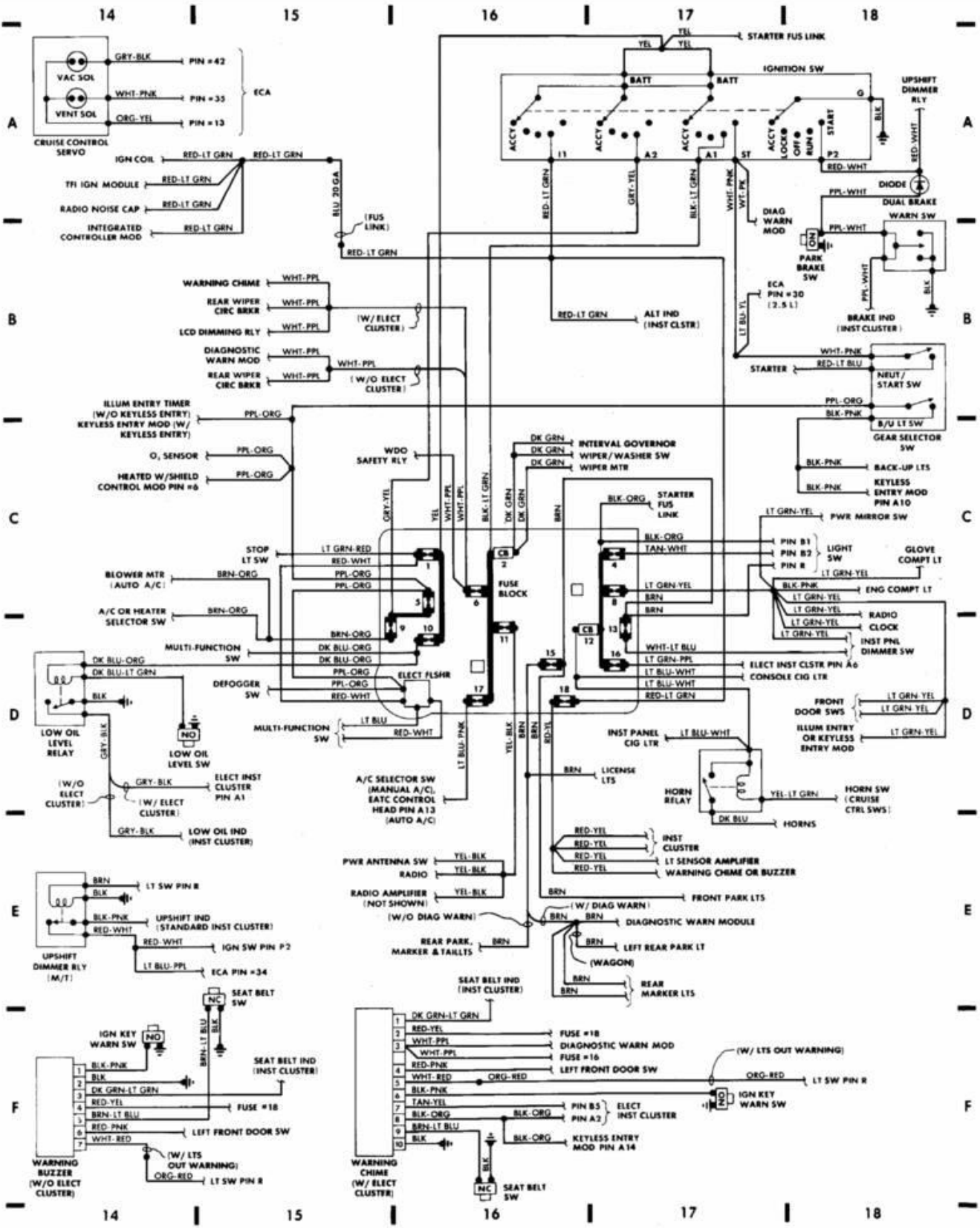

FUSE BLOCK & UNDERDASH

97371

WIRING DIAGRAMS

1987 Wiring Diagrams Ford Motor Co.

PAVLIN

Fig. 5: Underdash (Cont.)
1987 Ford Taurus LX

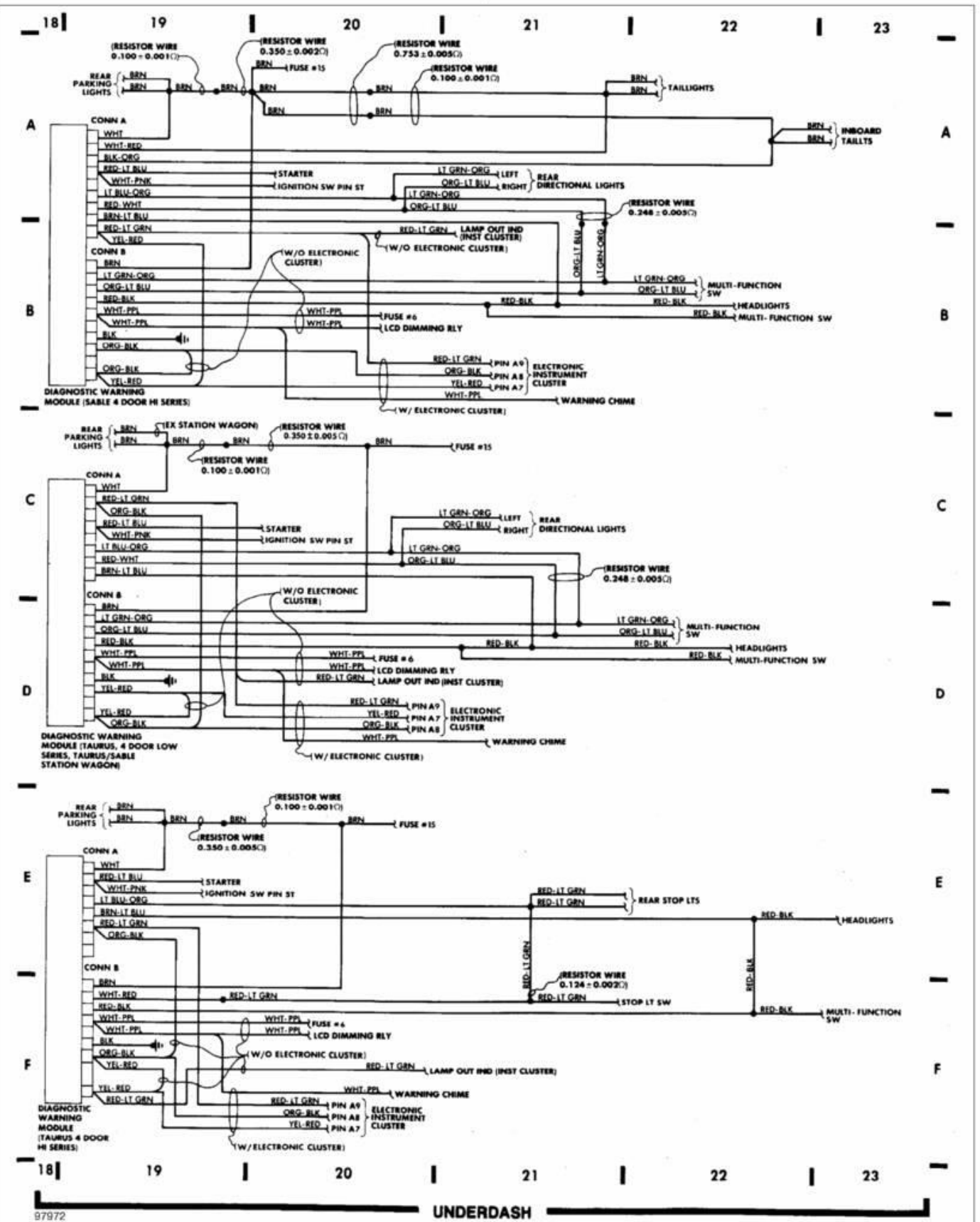

97972

UNDERDASH

WIRING DIAGRAMS

1987 Wiring Diagrams Ford Motor Co.

PAVLIN

Fig. 6: Underdash (Cont.) & Instrument Panel
1987 Ford Taurus LX

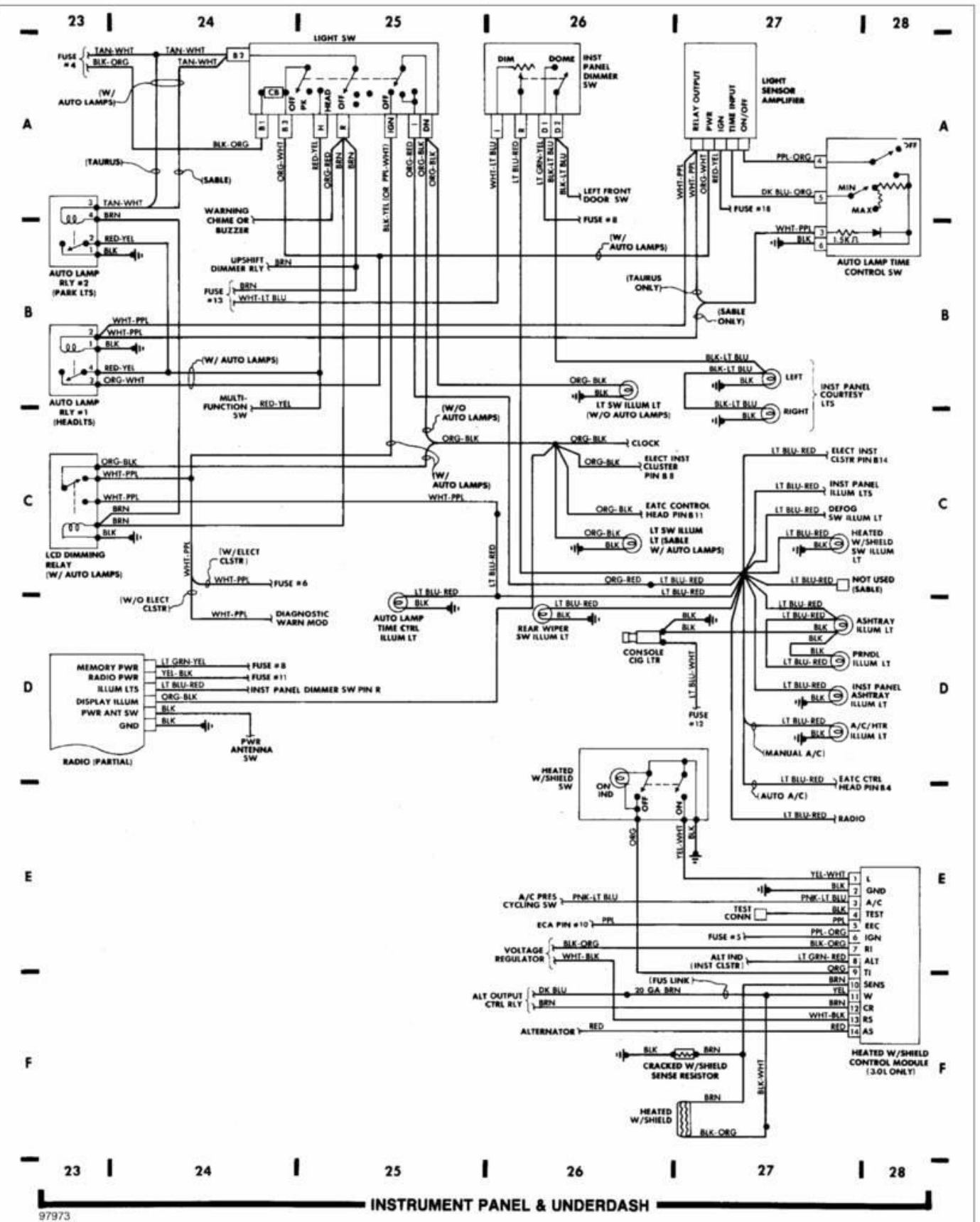

WIRING DIAGRAMS
1987 Wiring Diagrams Ford Motor Co.

PAVLIN

Fig. 7: Instrument Panel (Cont.)
1987 Ford Taurus LX

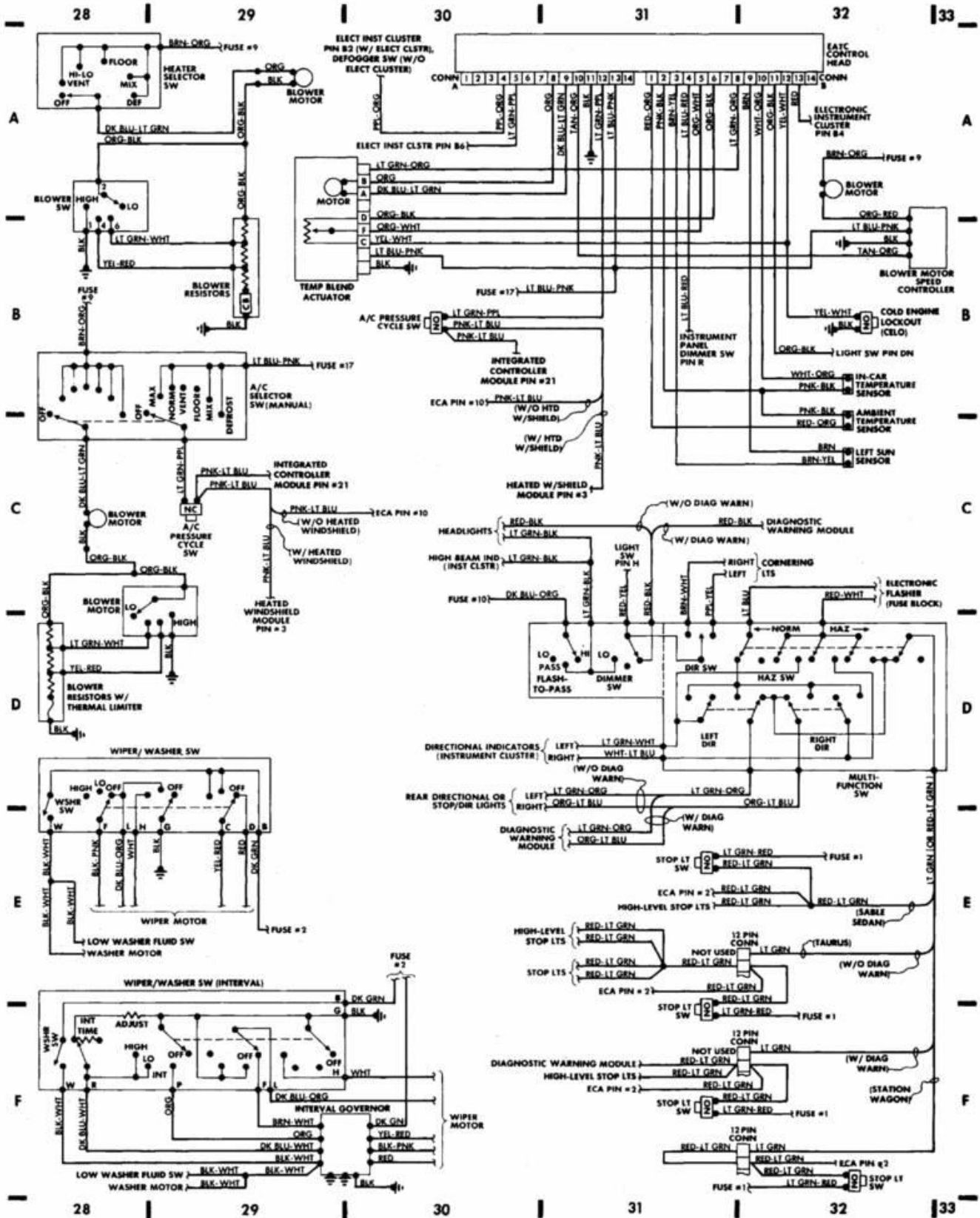

97974

INSTRUMENT PANEL

WIRING DIAGRAMS

1987 Wiring Diagrams Ford Motor Co.

PAVLIN

Fig. 8: Instrument Panel (Cont.)
1987 Ford Taurus LX

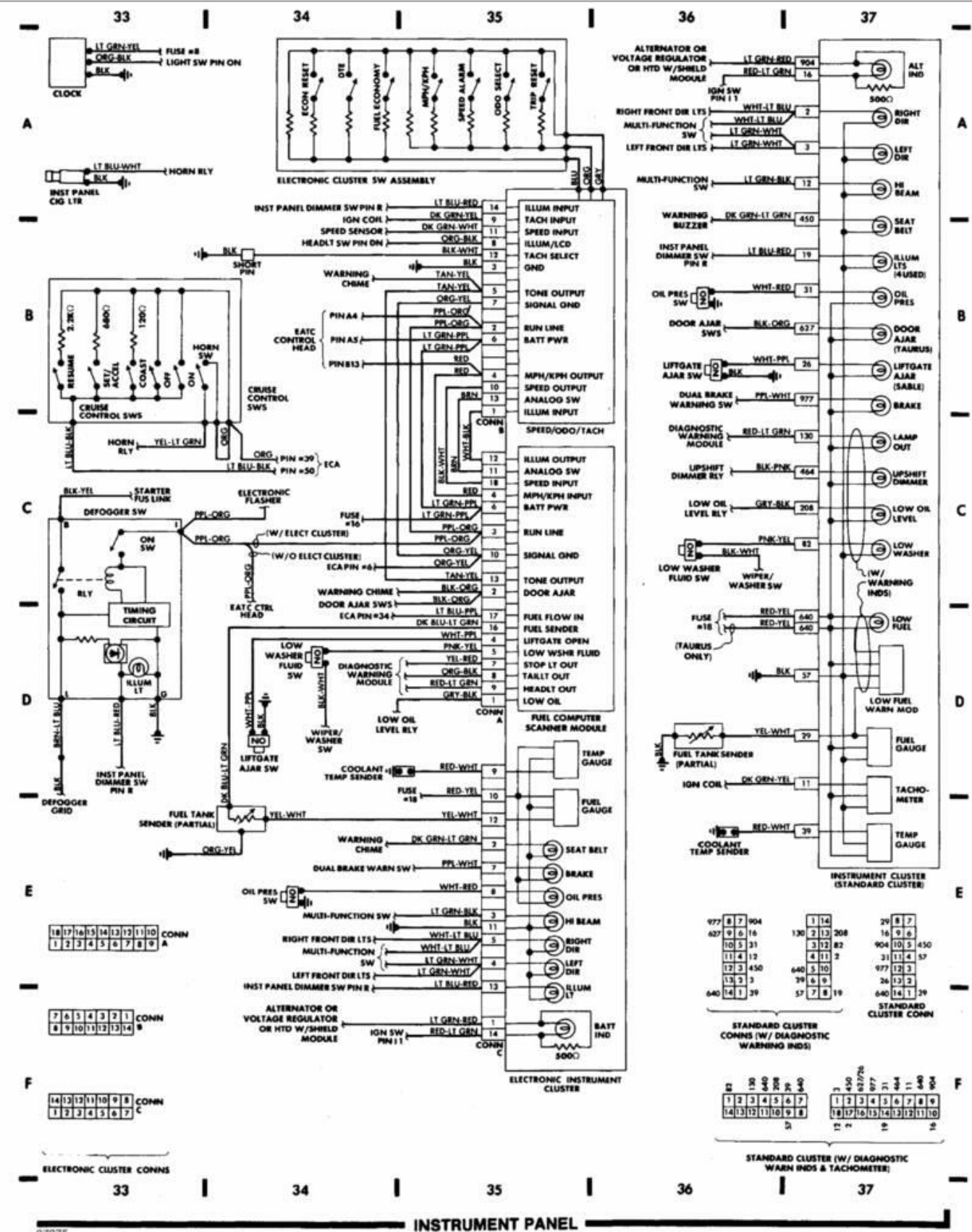

WIRING DIAGRAMS

1987 Wiring Diagrams Ford Motor Co.

PAVLIN

Fig. 9: Rear Compartment & Accessories
1987 Ford Taurus LX

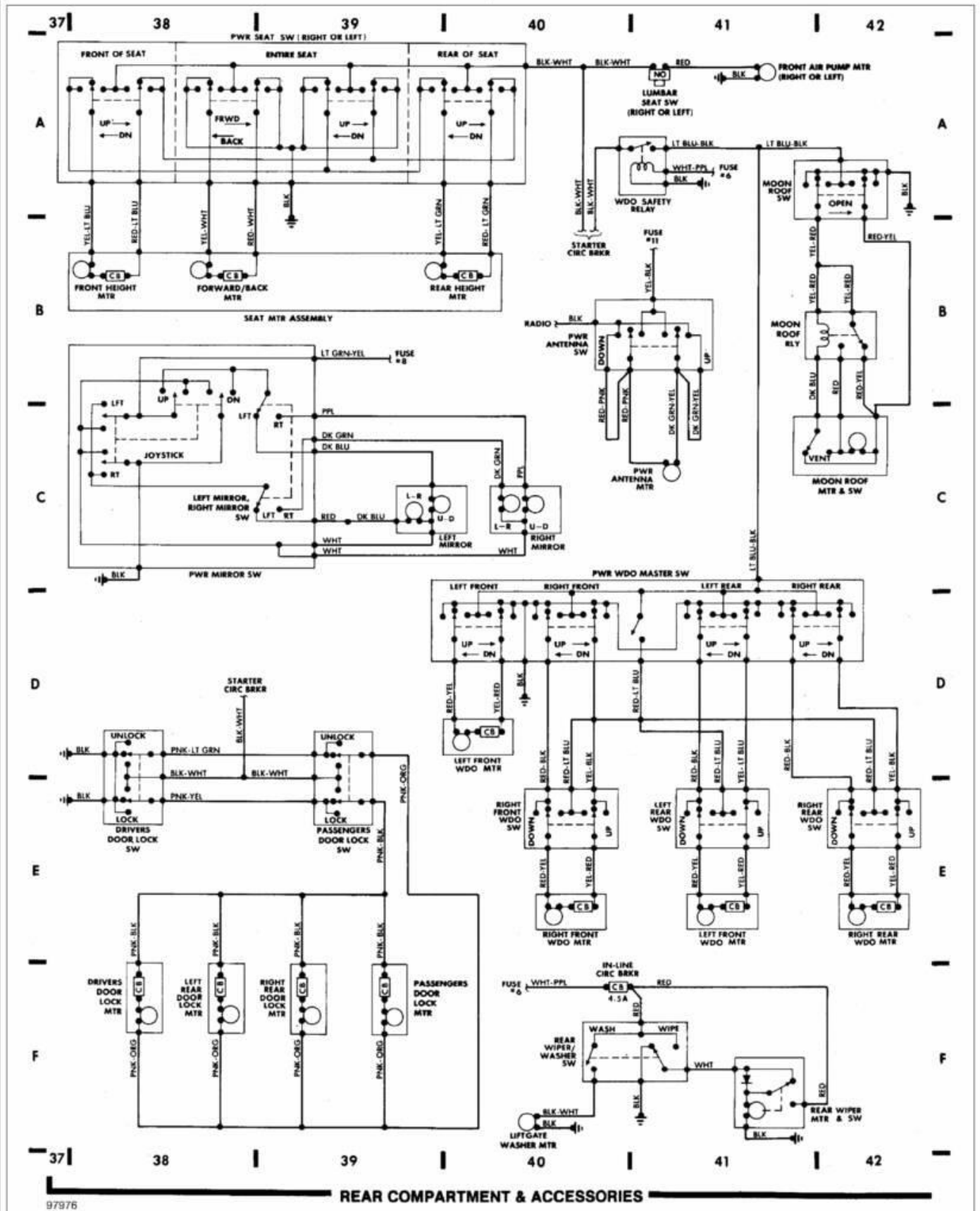

WIRING DIAGRAMS
1987 Wiring Diagrams Ford Motor Co.

PAVLIN

Fig. 10: Rear Compartment & Accessories (Cont.)
1987 Ford Taurus LX

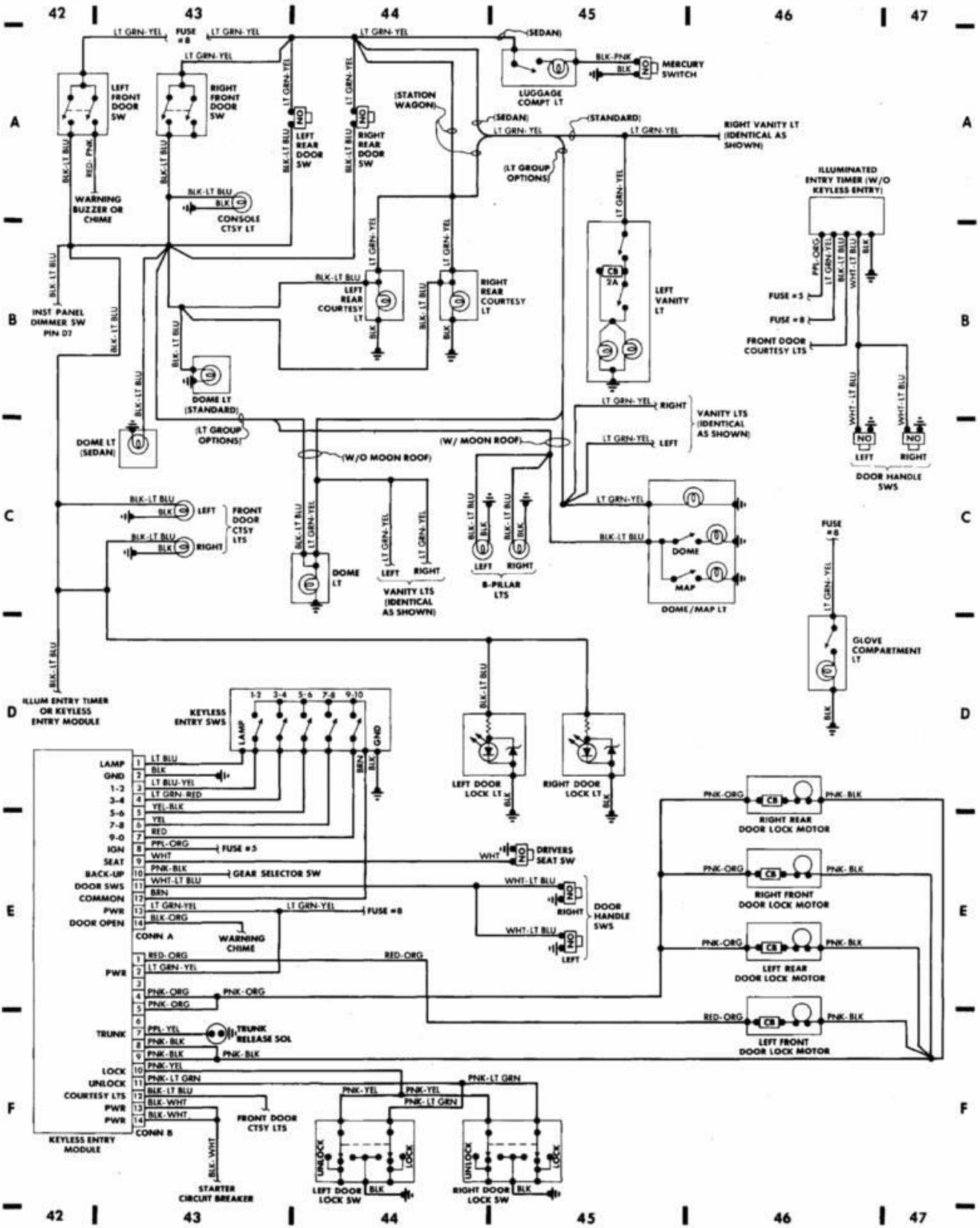

REAR COMPARTMENT & ACCESSORIES

97977

WIRING DIAGRAMS

1987 Wiring Diagrams Ford Motor Co.

PAVLIN

Fig. 11: Rear Compartment & Accessories (Cont.)
1987 Ford Taurus LX

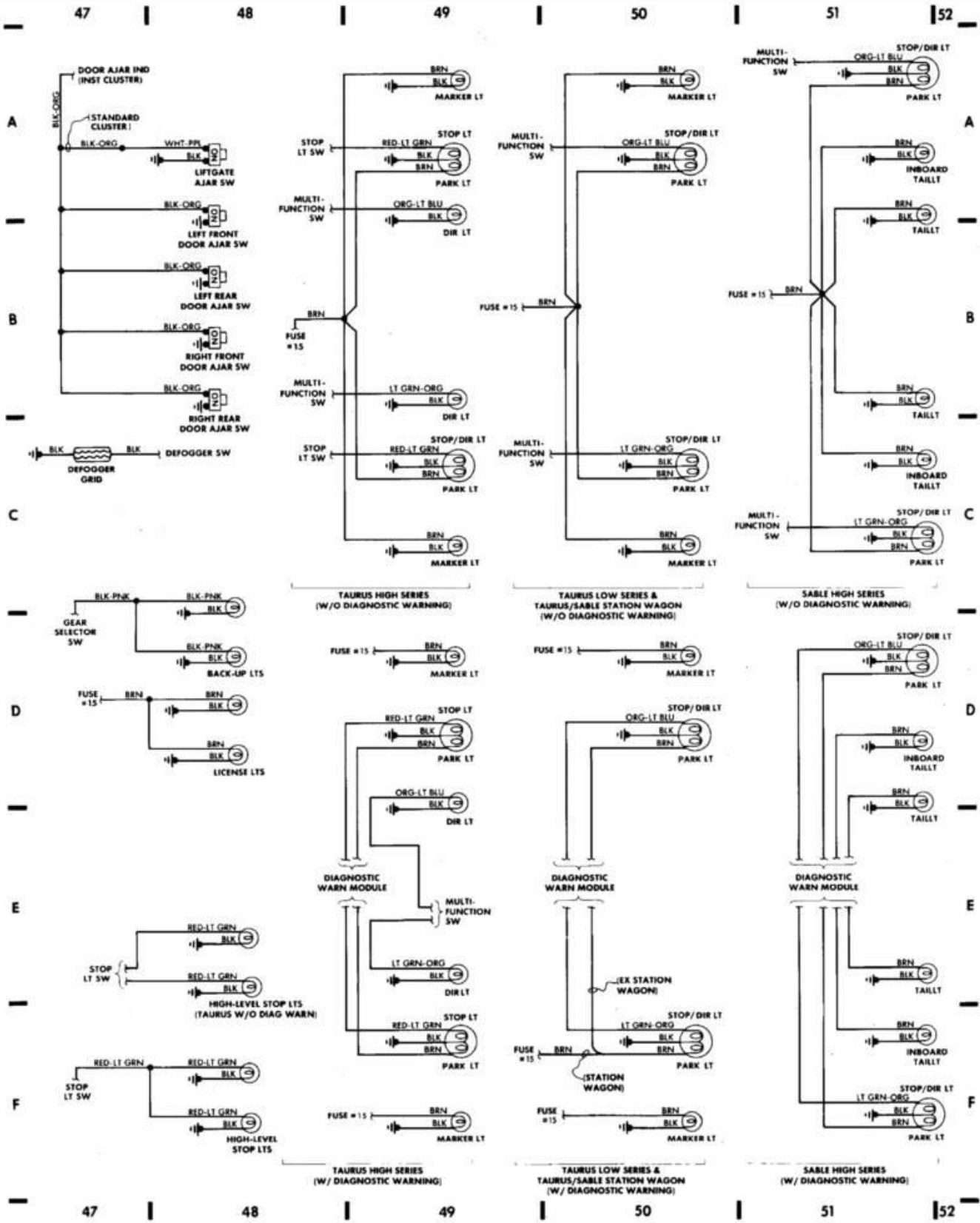

REAR COMPARTMENT & ACCESSORIES

97978