

**1989 System Wiring Diagrams
Ford - Taurus**

PAVLIN

Fig. 1: 2.5L, Cooling Fan Circuit
1989 Ford Taurus LX

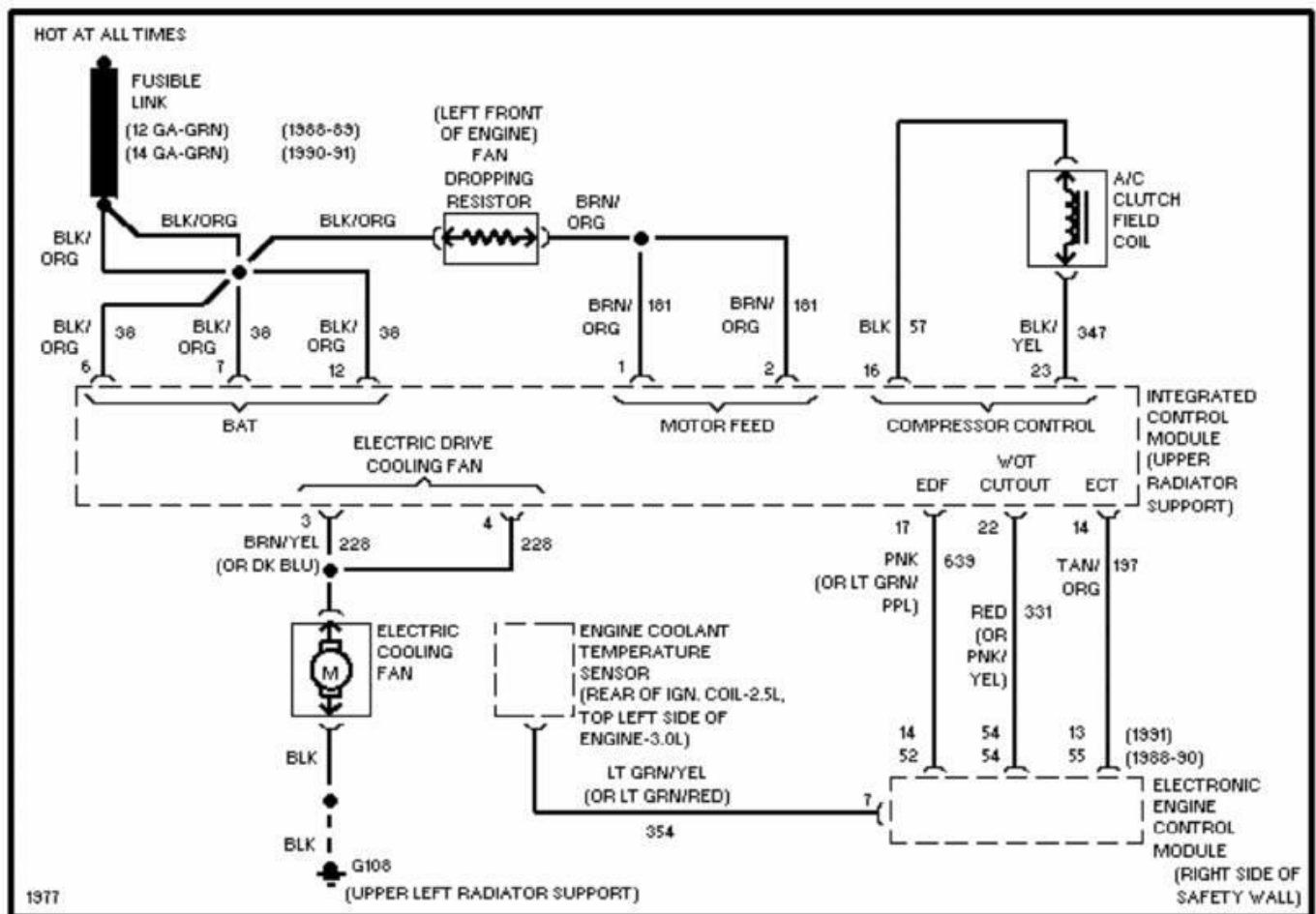

1977

1989 System Wiring Diagrams
Ford - Taurus

PAVLIN

Fig. 2: 3.0L SHO, Cooling Fan Circuit
1989 Ford Taurus LX

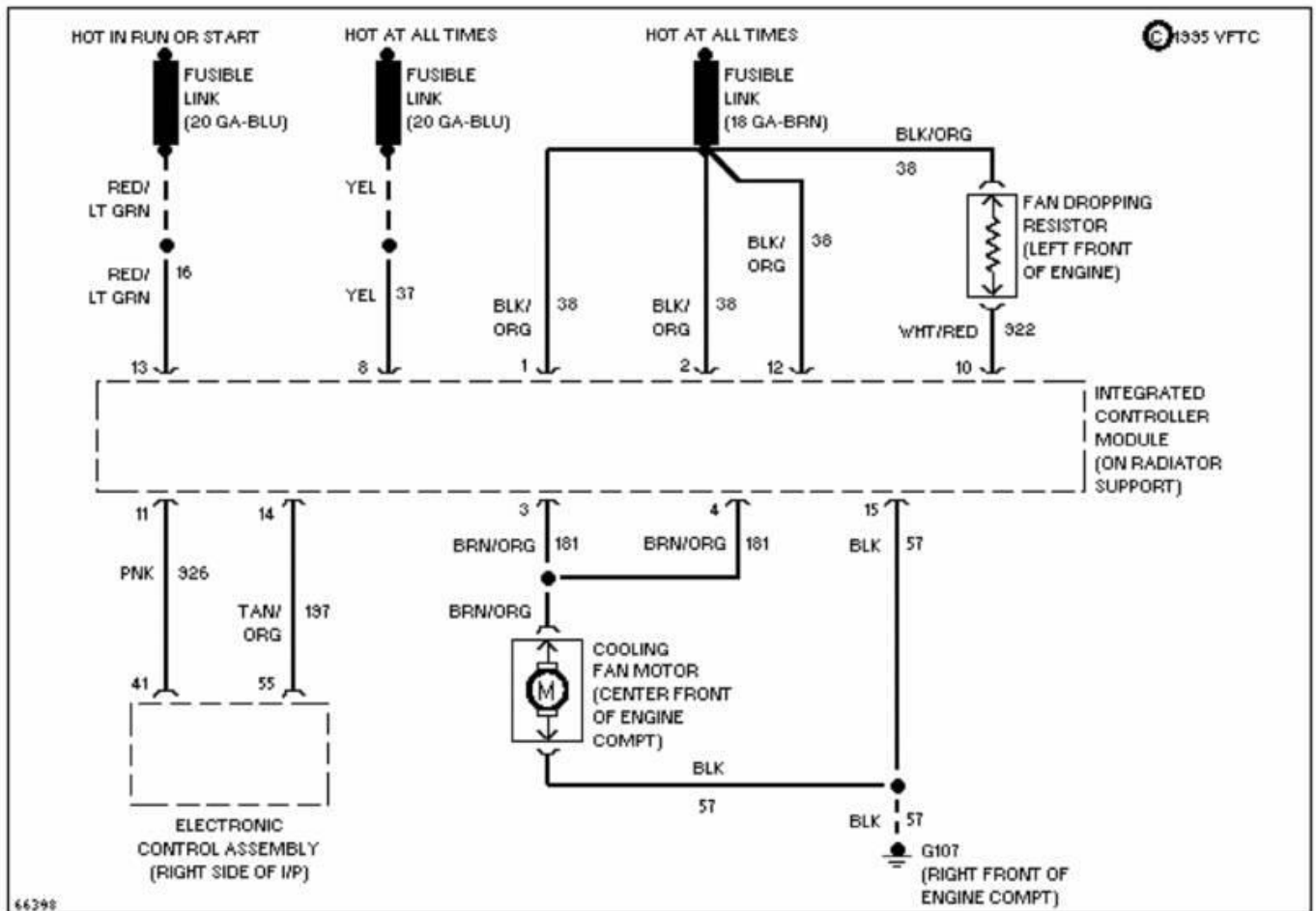

**1989 System Wiring Diagrams
Ford - Taurus**

PAVLIN

Fig. 3: 3.0L, Cooling Fan Circuit
1989 Ford Taurus LX

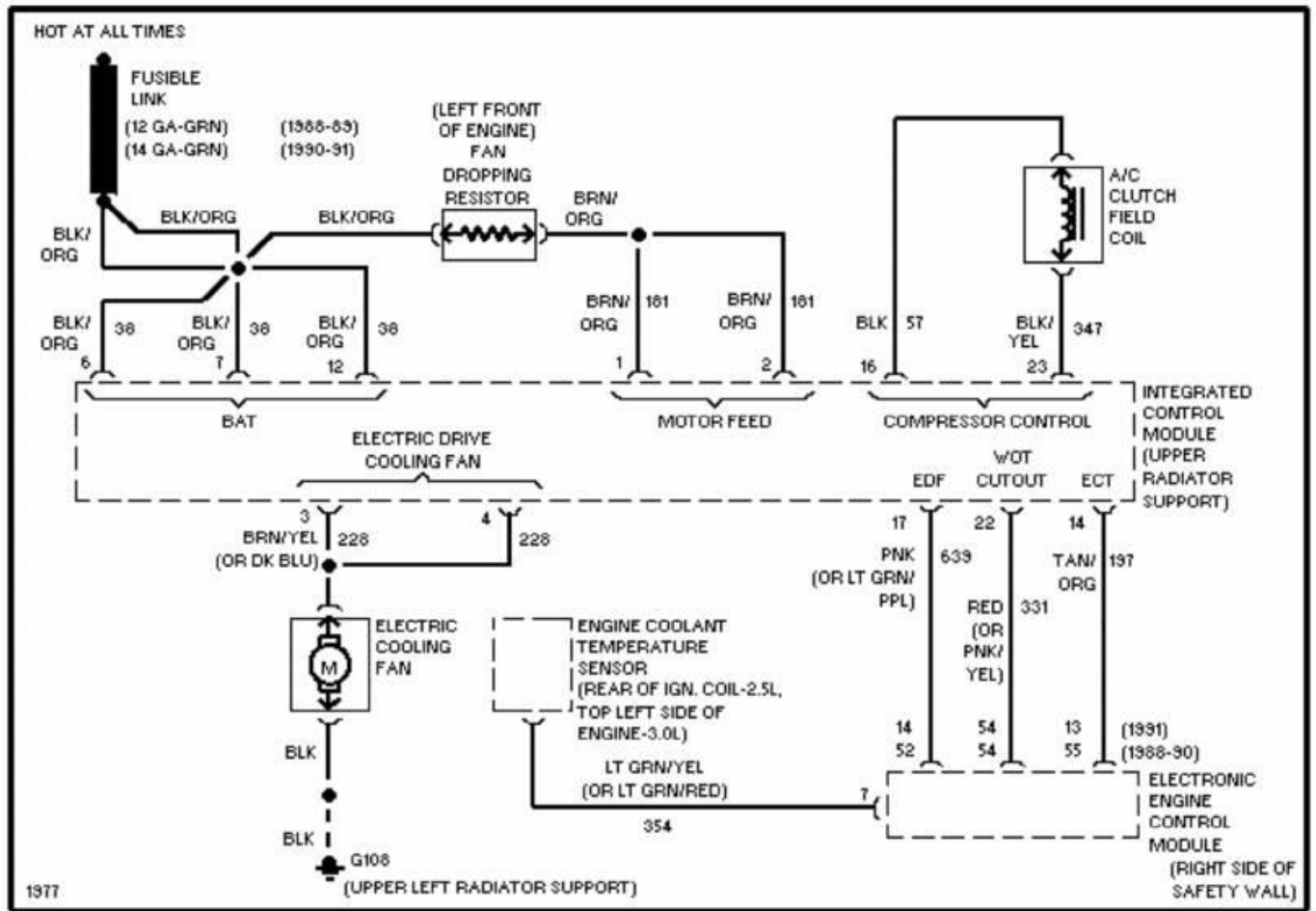

1977

1989 System Wiring Diagrams
Ford - Taurus

PAVLIN

Fig. 4: 3.8L, Cooling Fan Circuit
1989 Ford Taurus LX

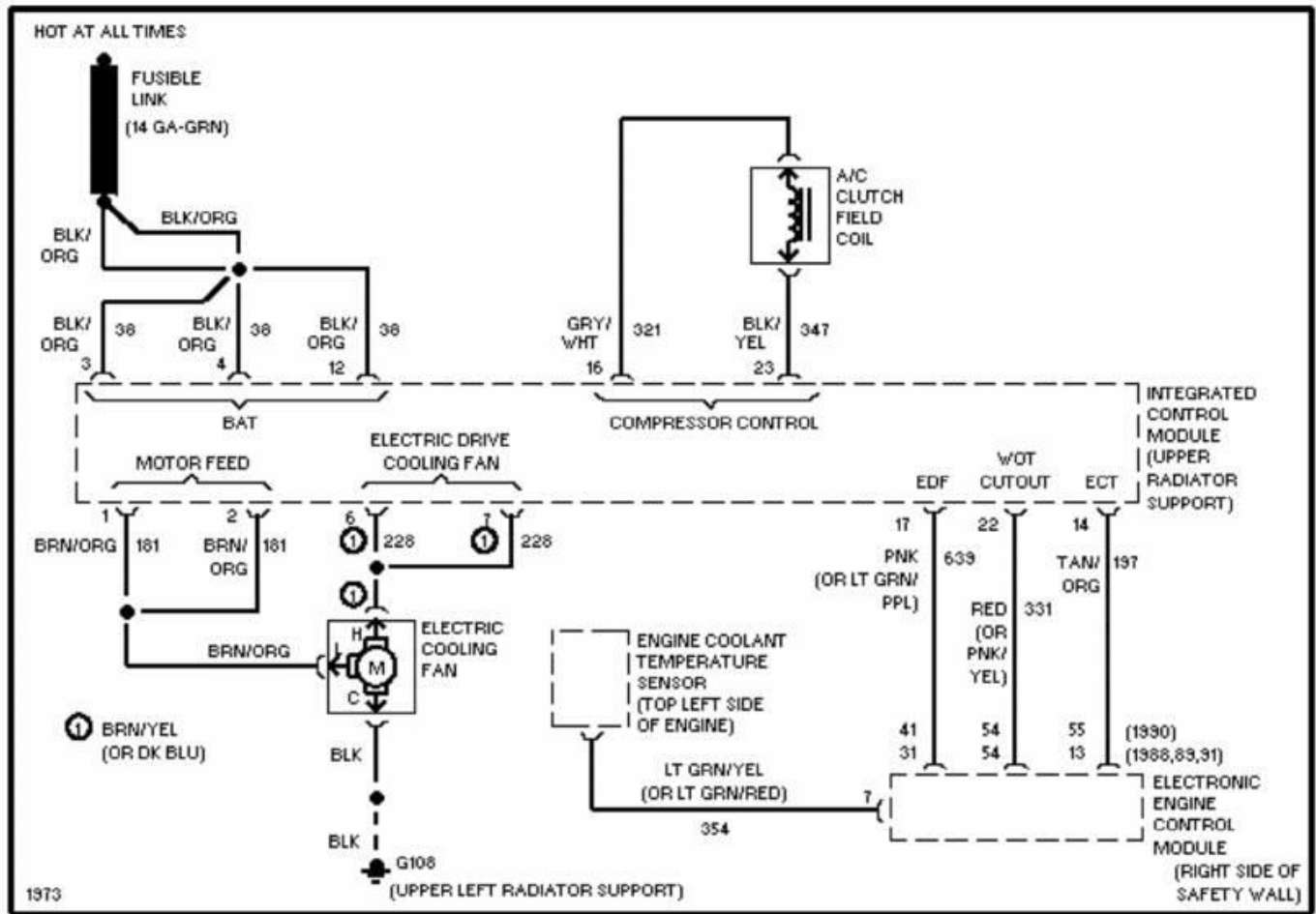

1989 System Wiring Diagrams
Ford - Taurus

PAVLIN

Fig. 5: Defogger Circuit
1989 Ford Taurus LX

© 1985 VFTC

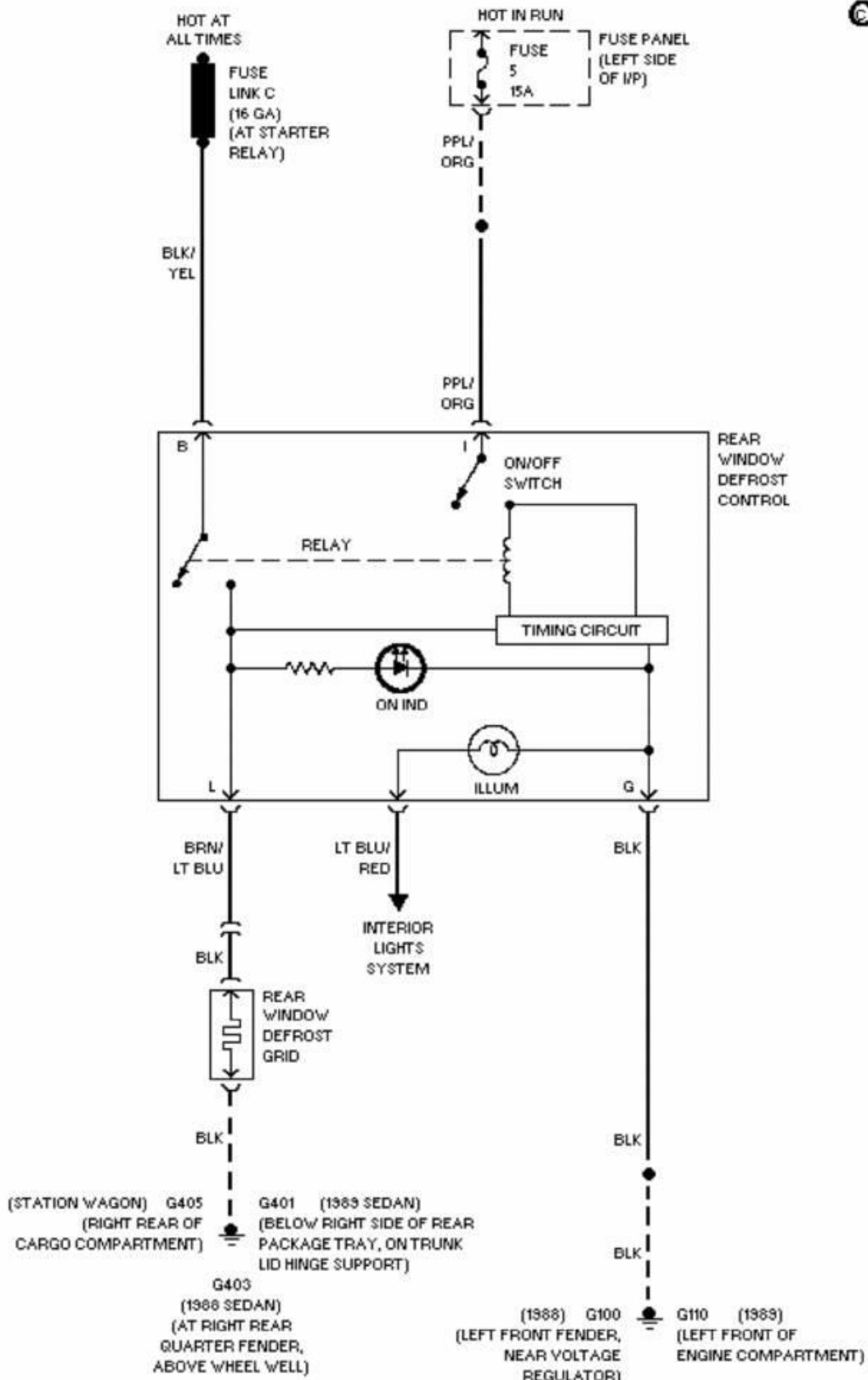

59621

1989 System Wiring Diagrams
Ford - Taurus

PAVLIN

Fig. 6: Horn Circuit
1989 Ford Taurus LX

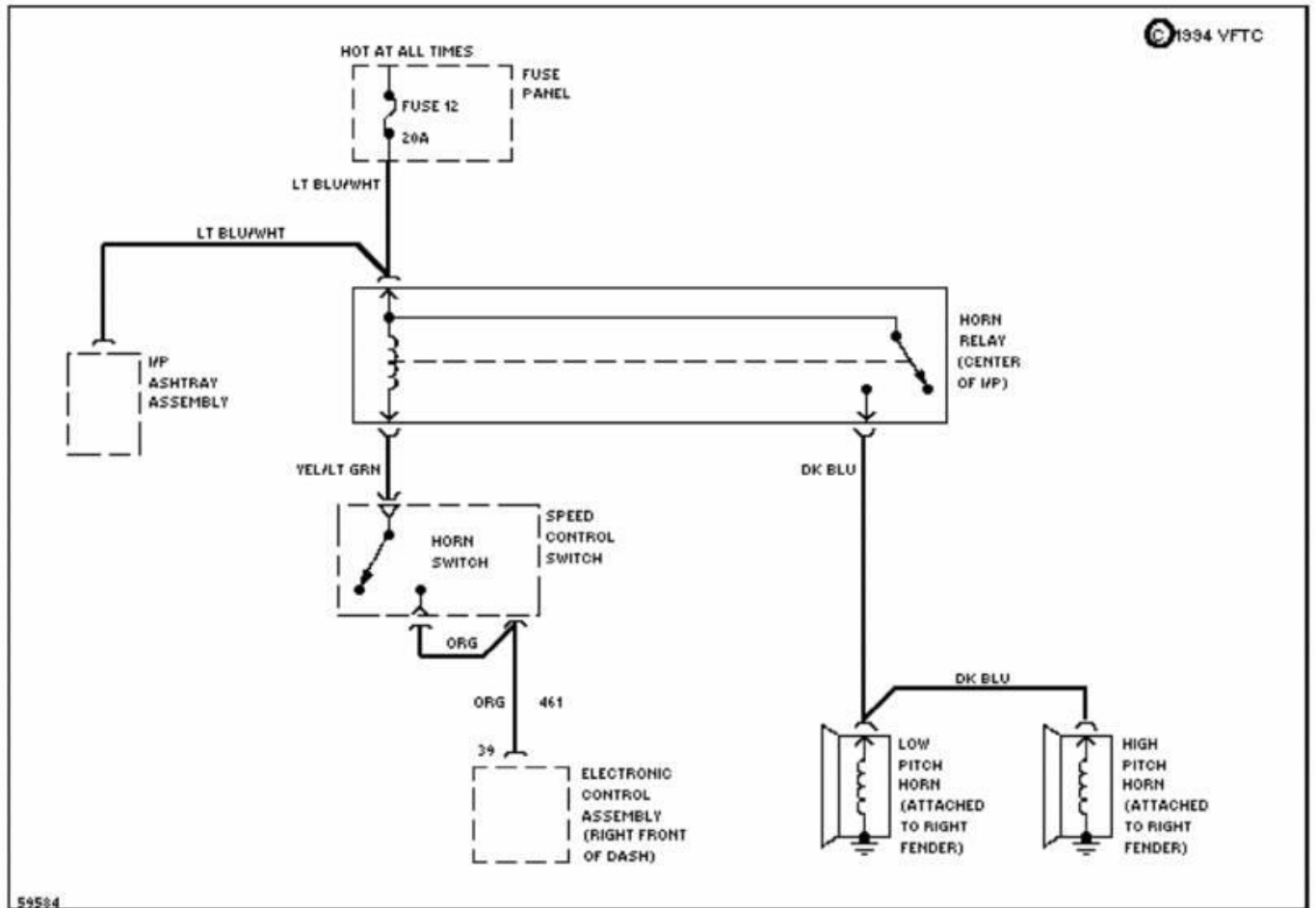

1989 System Wiring Diagrams
Ford - Taurus

PAVLIN

Fig. 7: Power Antenna Circuit
1989 Ford Taurus LX

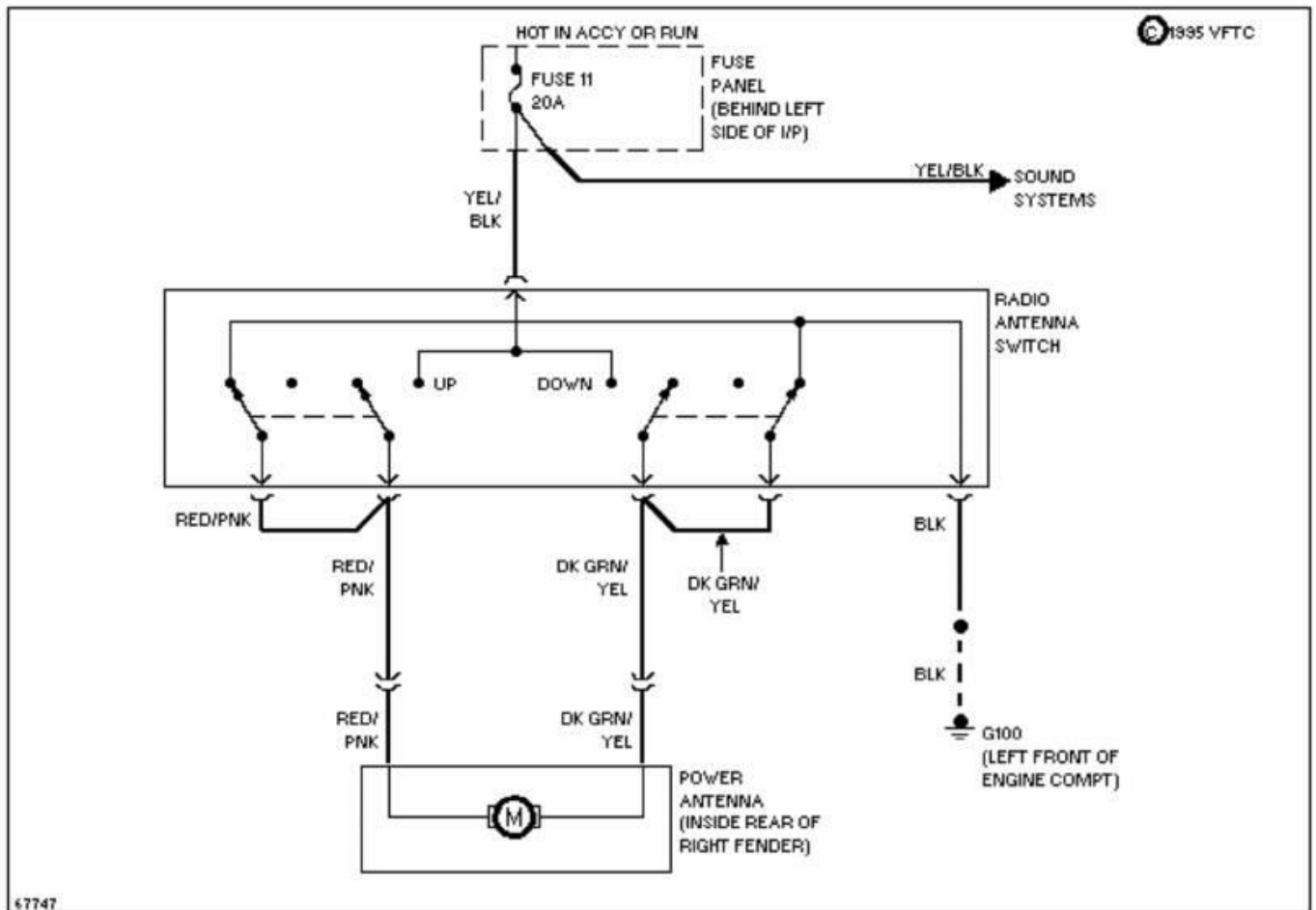

1989 System Wiring Diagrams
Ford - Taurus

PAVLIN

Fig. 8: Door Lock Circuit
1989 Ford Taurus LX

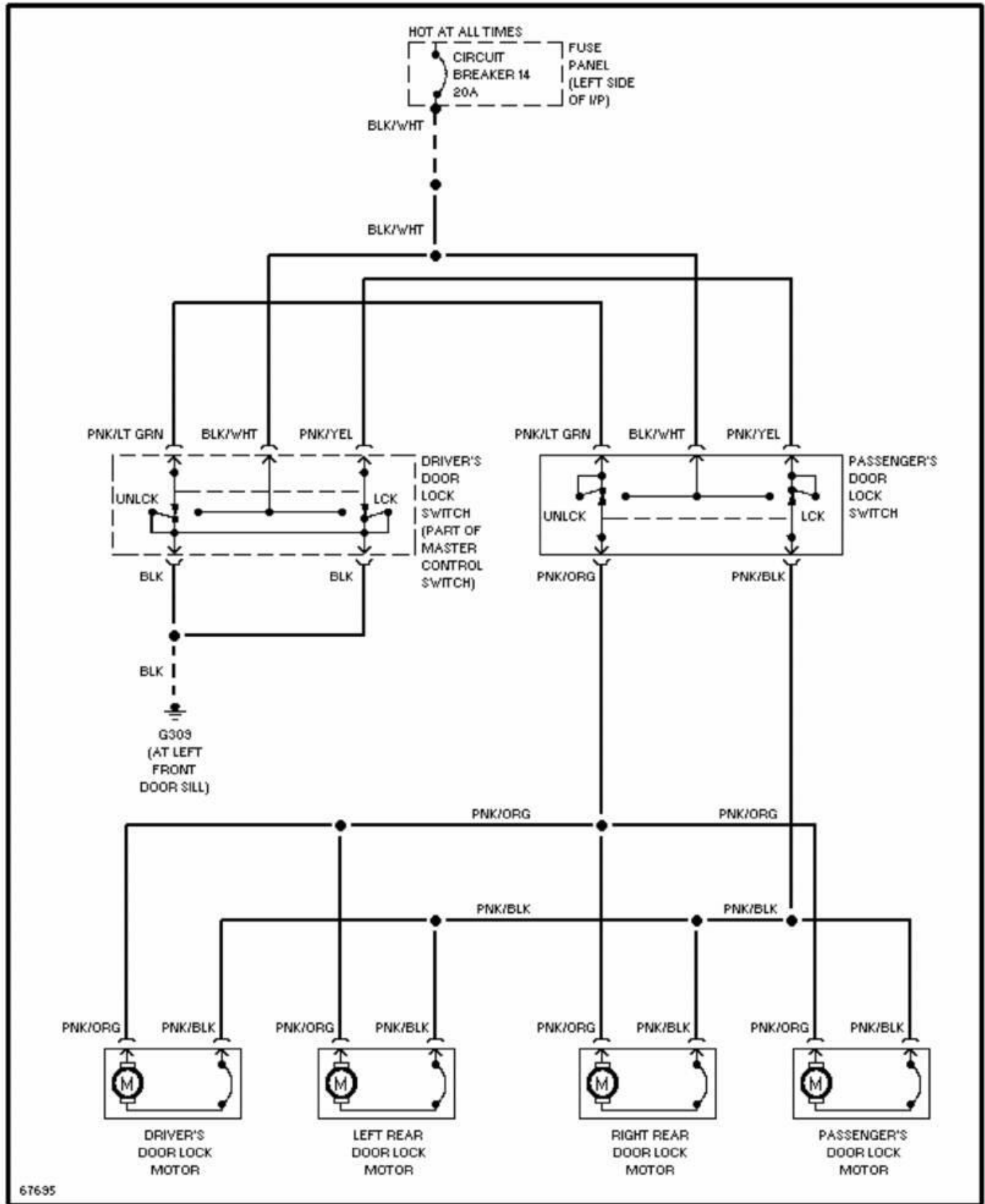

1989 System Wiring Diagrams Ford - Taurus

PAVLIN

Fig. 9: Keyless Entry Circuit
1989 Ford Taurus LX

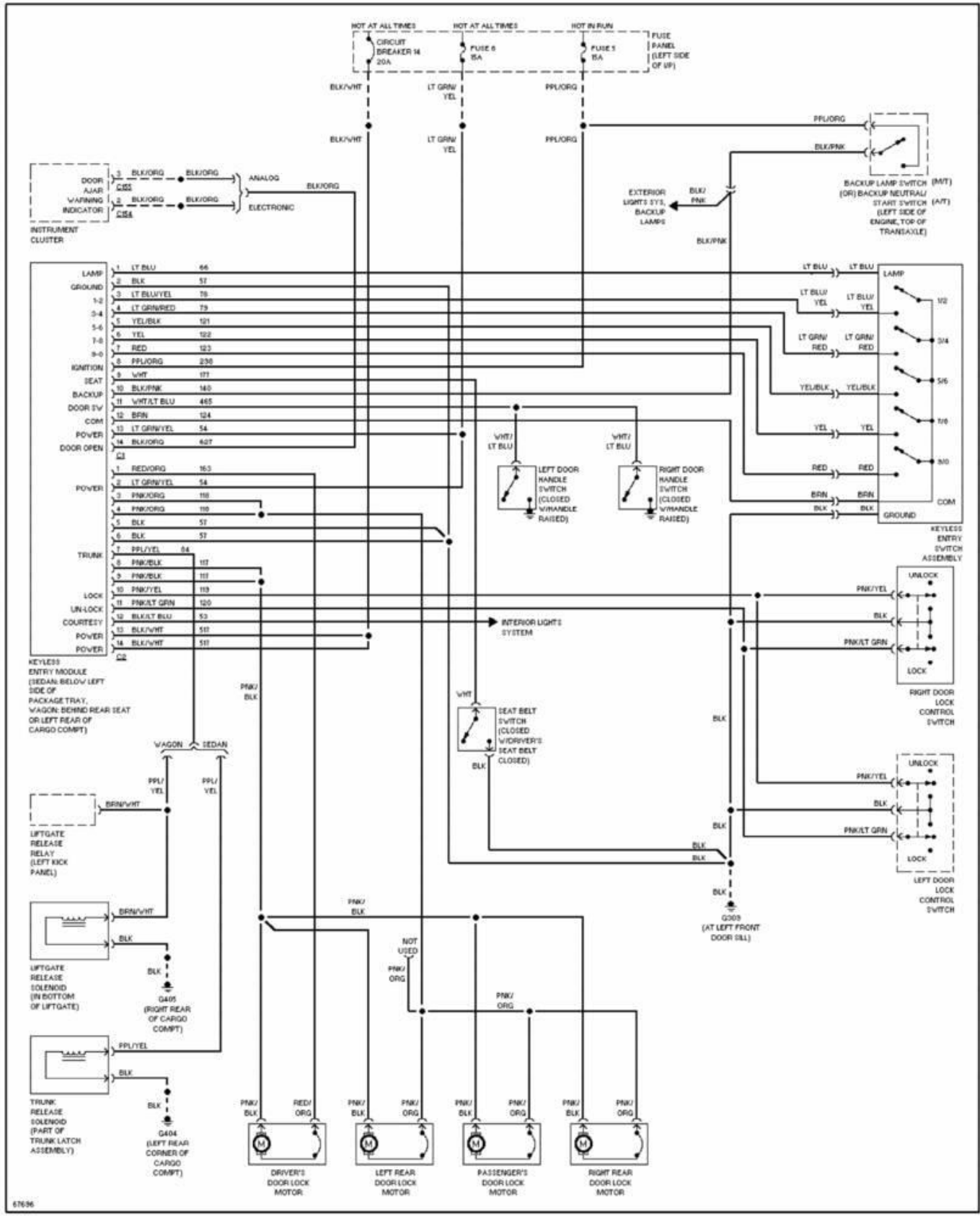

67636

1989 System Wiring Diagrams
Ford - Taurus

PAVLIN

Fig. 10: Power Mirror Circuit
1989 Ford Taurus LX

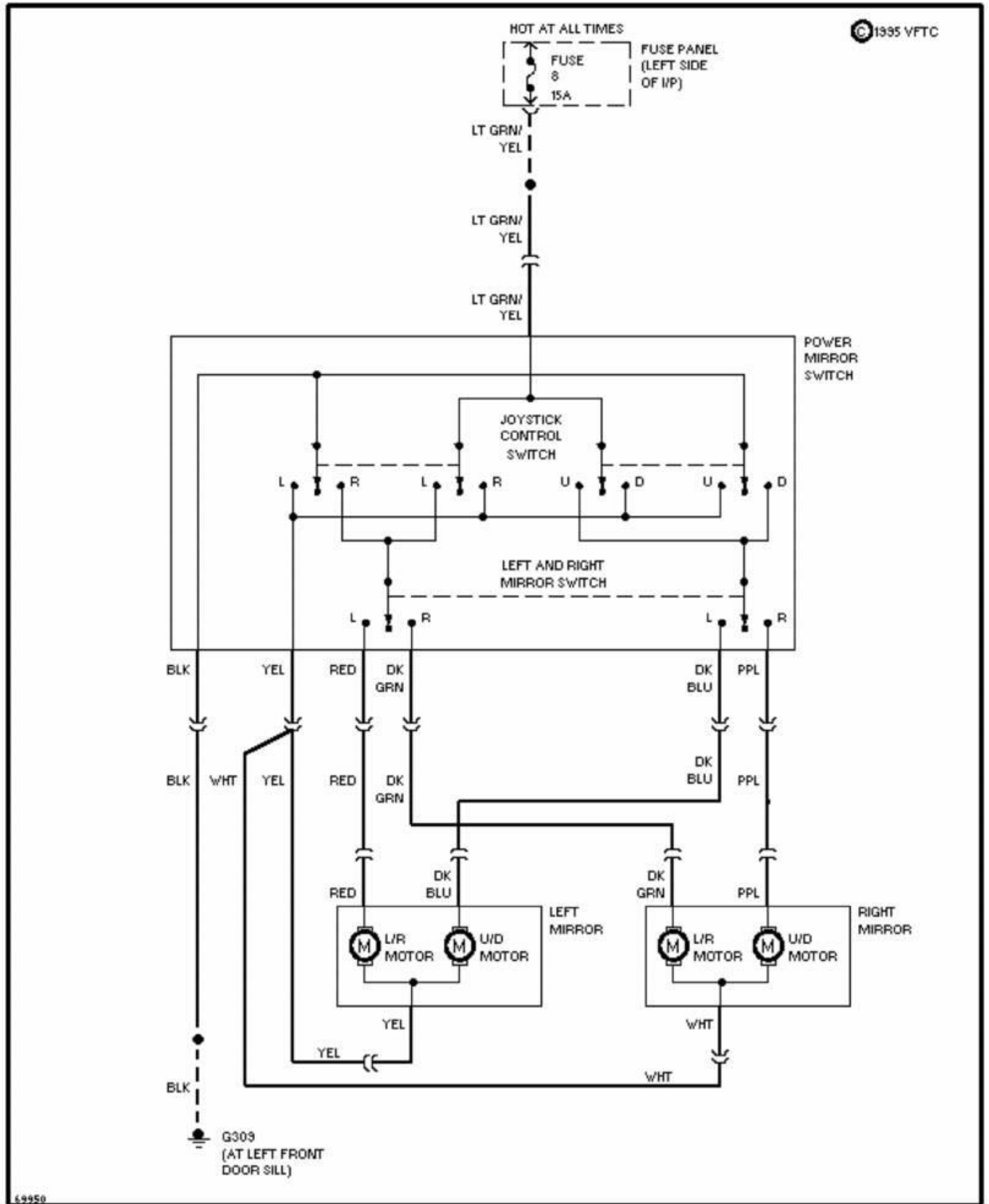

1989 System Wiring Diagrams
Ford - Taurus

PAVLIN

Fig. 11: Lumbar Circuit
1989 Ford Taurus LX

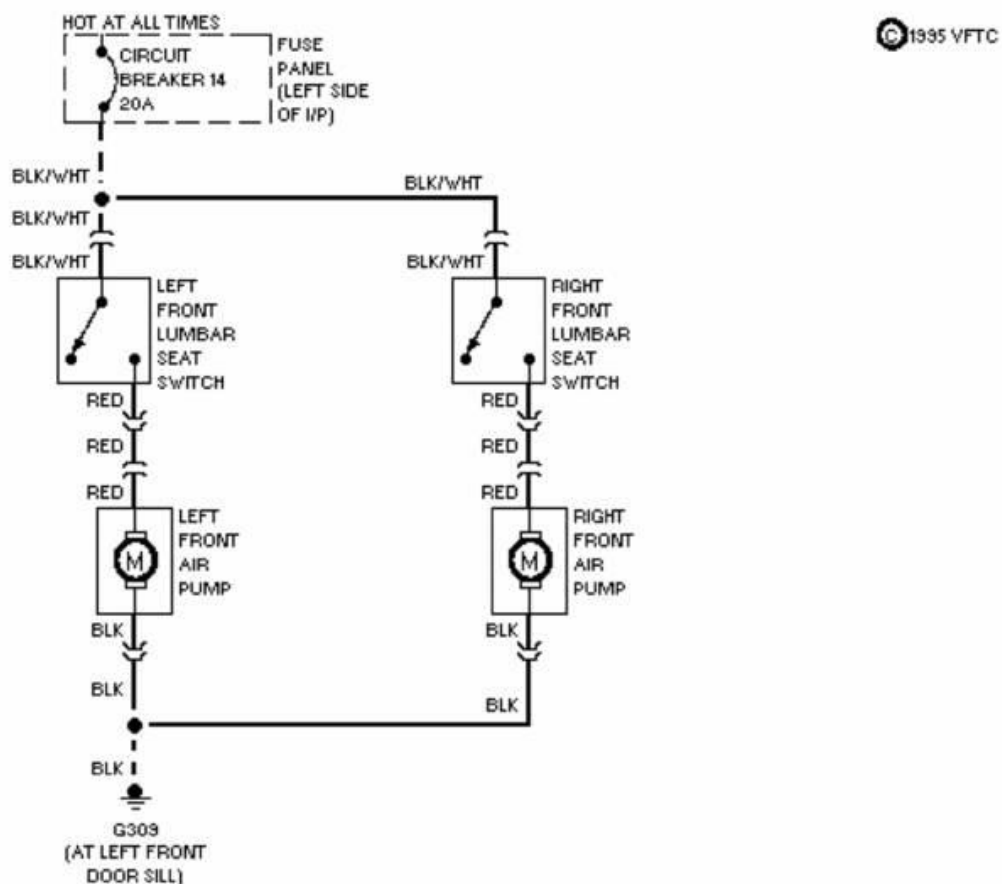

66515

1989 System Wiring Diagrams
Ford - Taurus

PAVLIN

Fig. 12: Power Seat Circuit
1989 Ford Taurus LX

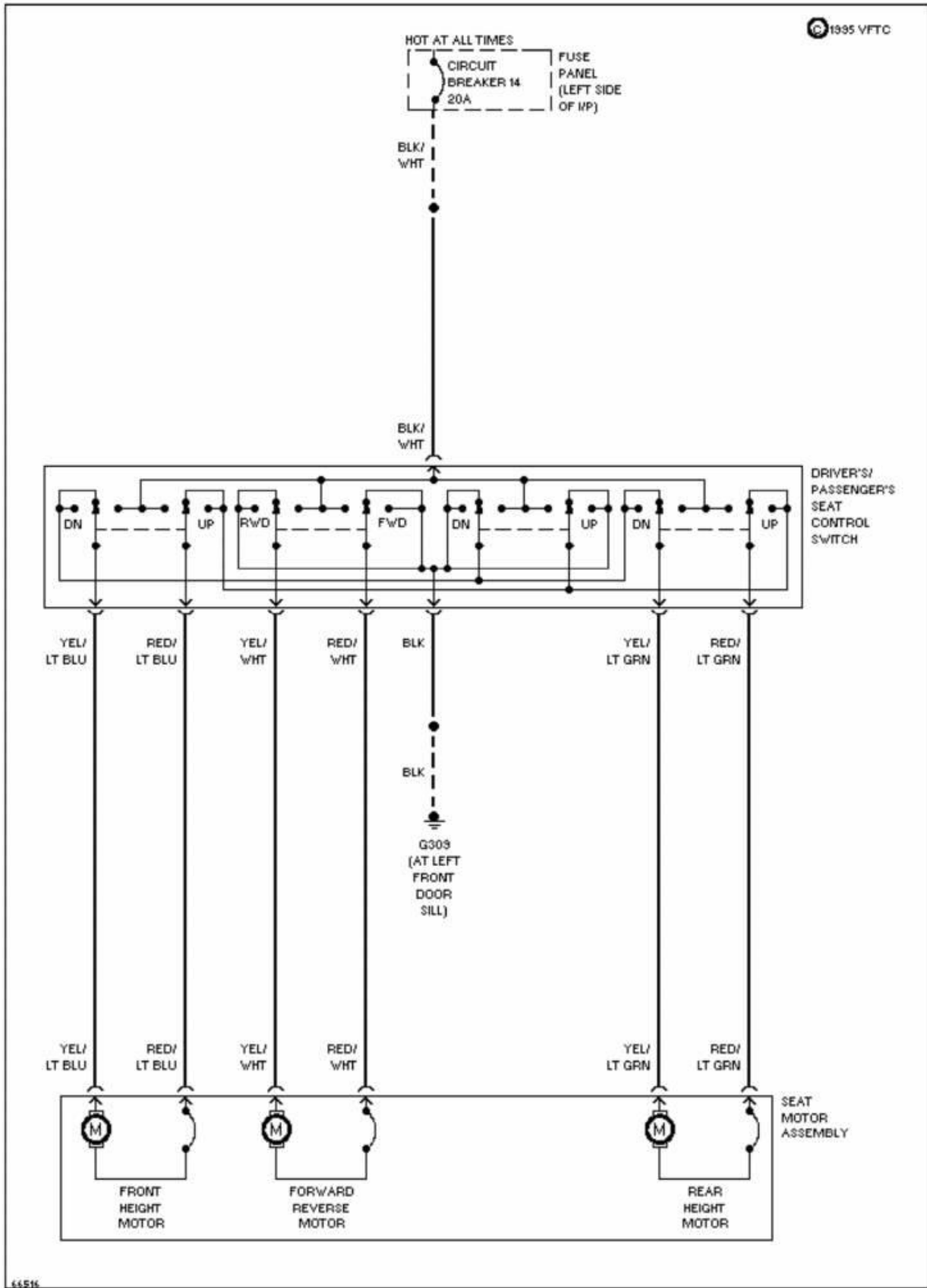

1989 System Wiring Diagrams
Ford - Taurus

PAVLIN

Fig. 13: Power Window Circuit
1989 Ford Taurus LX

1989 VFTC

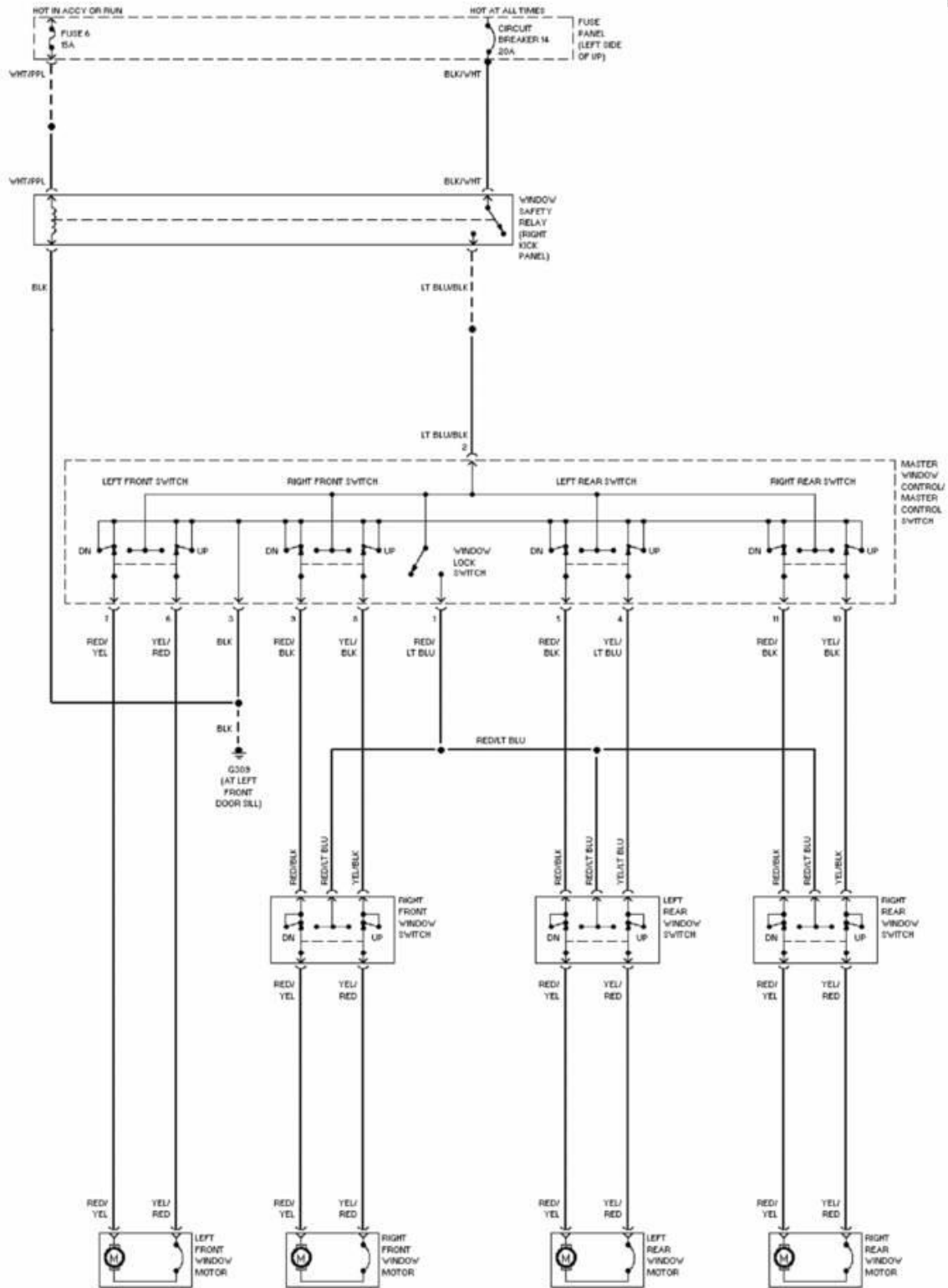

LSM1

1989 System Wiring Diagrams
Ford - Taurus

PAVLIN

Fig. 14: Premium Sound Radio Circuit, Standard/AAV
1989 Ford Taurus LX

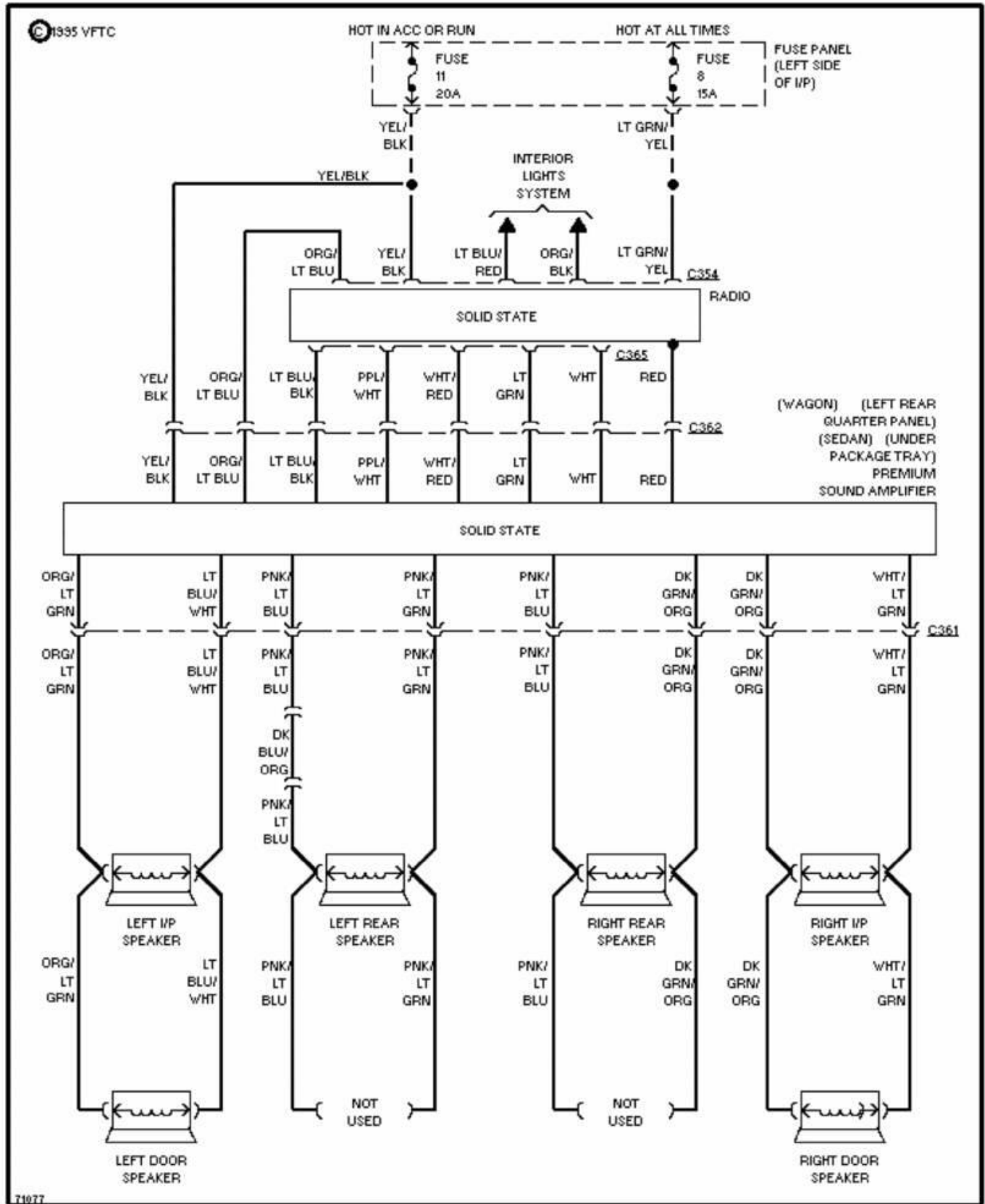

1989 System Wiring Diagrams
Ford - Taurus

PAVLIN

Fig. 15: Premium Sound Radio Circuit, W/ EPC/JBL
1989 Ford Taurus LX

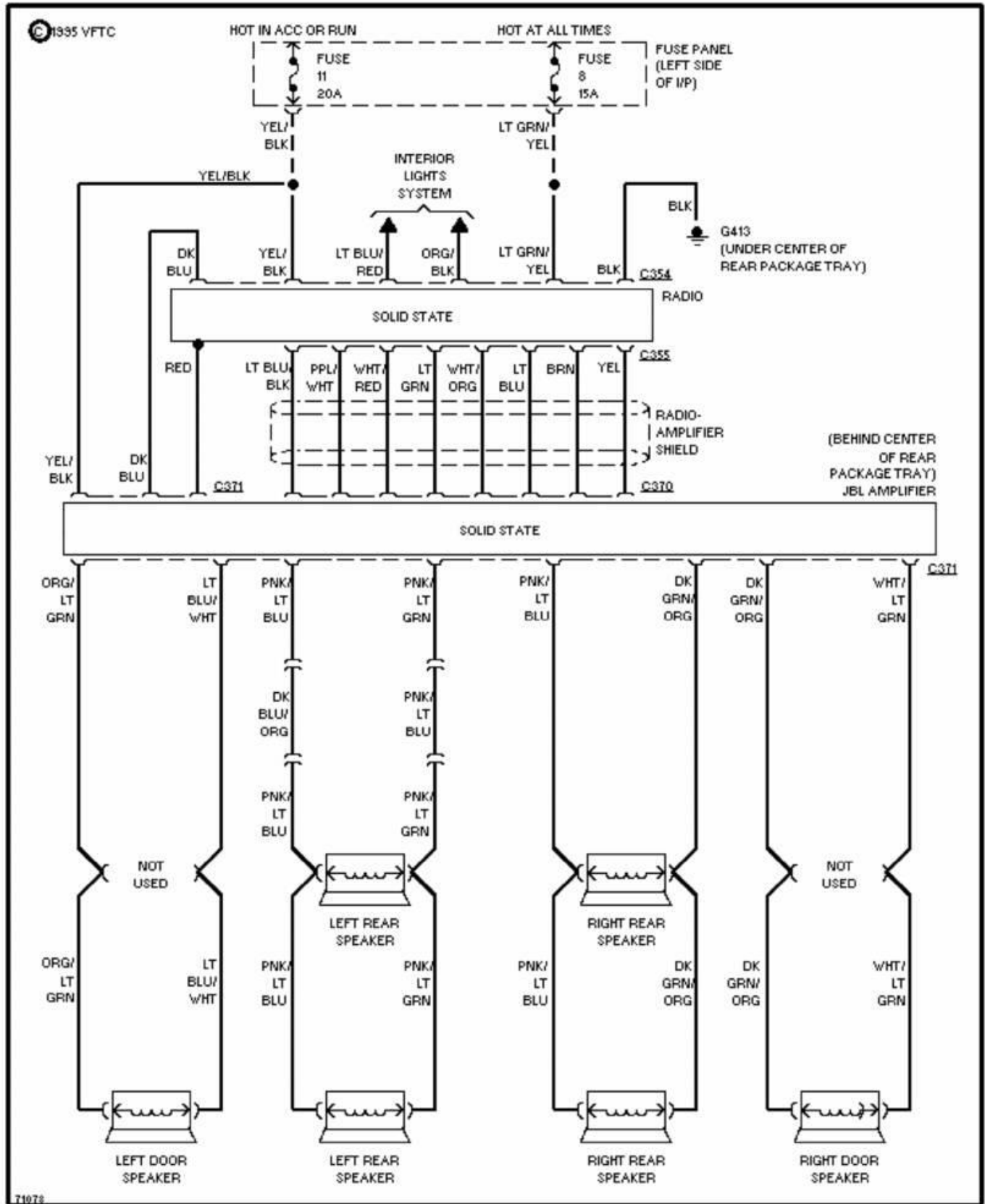

1989 System Wiring Diagrams
Ford - Taurus

PAVLIN

Fig. 16: Stereo Radio Circuit
1989 Ford Taurus LX

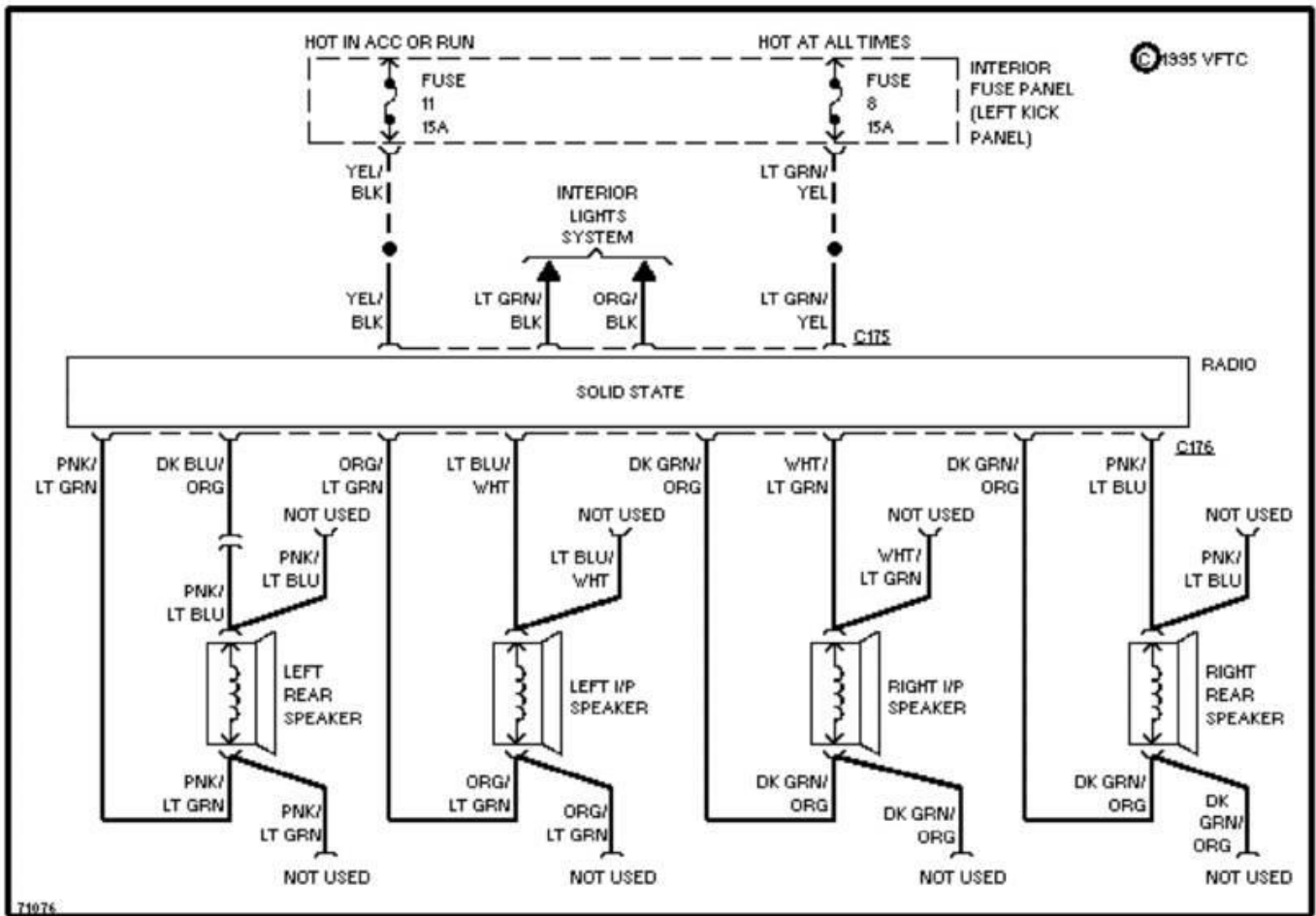

1989 System Wiring Diagrams
Ford - Taurus

PAVLIN

Fig. 17: 2.5L, Charging Circuit
1989 Ford Taurus LX

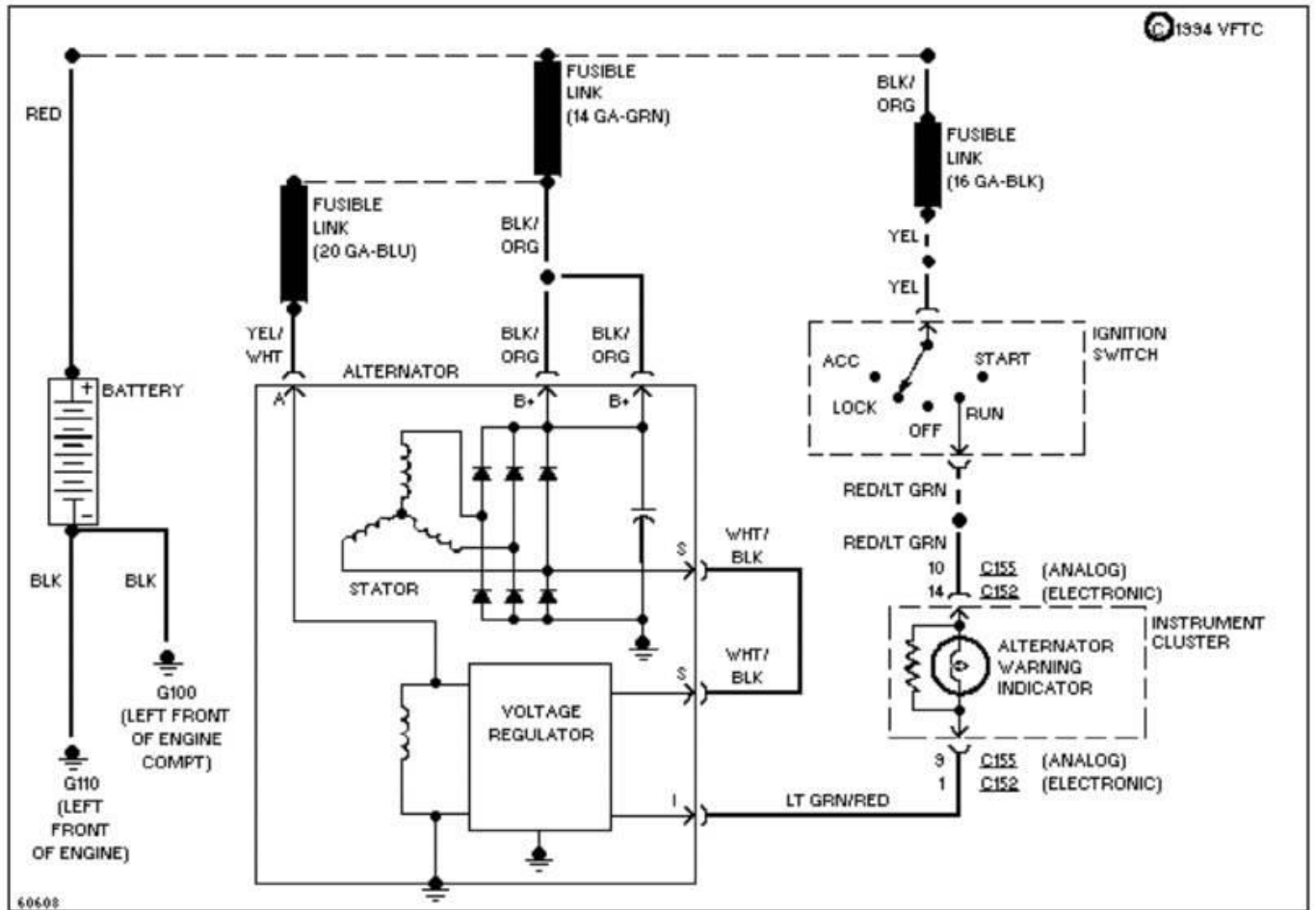

1989 System Wiring Diagrams
Ford - Taurus

PAVLIN

Fig. 18: Starting Circuit
1989 Ford Taurus LX

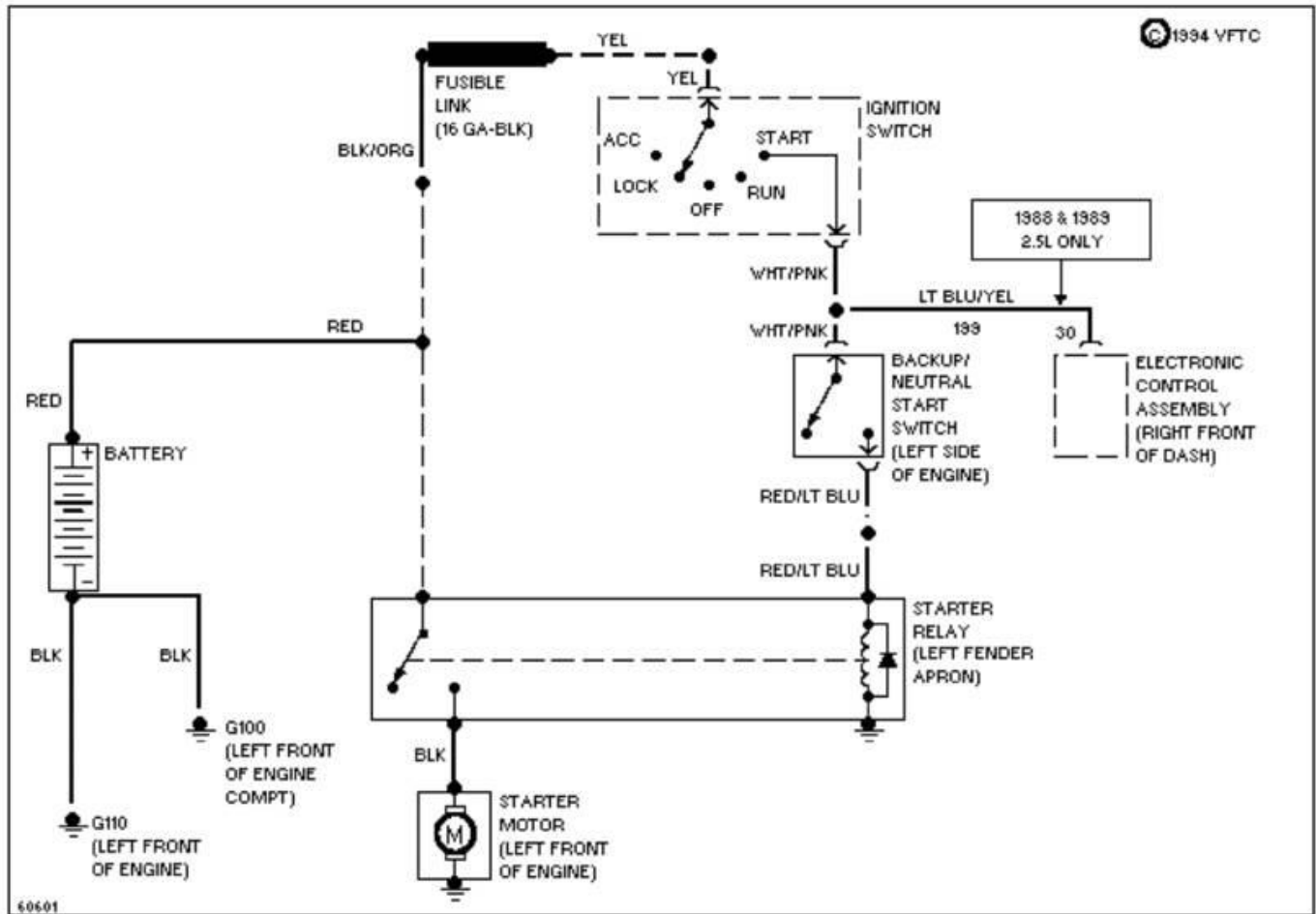

1989 System Wiring Diagrams
Ford - Taurus

PAVLIN

Fig. 19: 3.0L SHO, Charging Circuit
1989 Ford Taurus LX

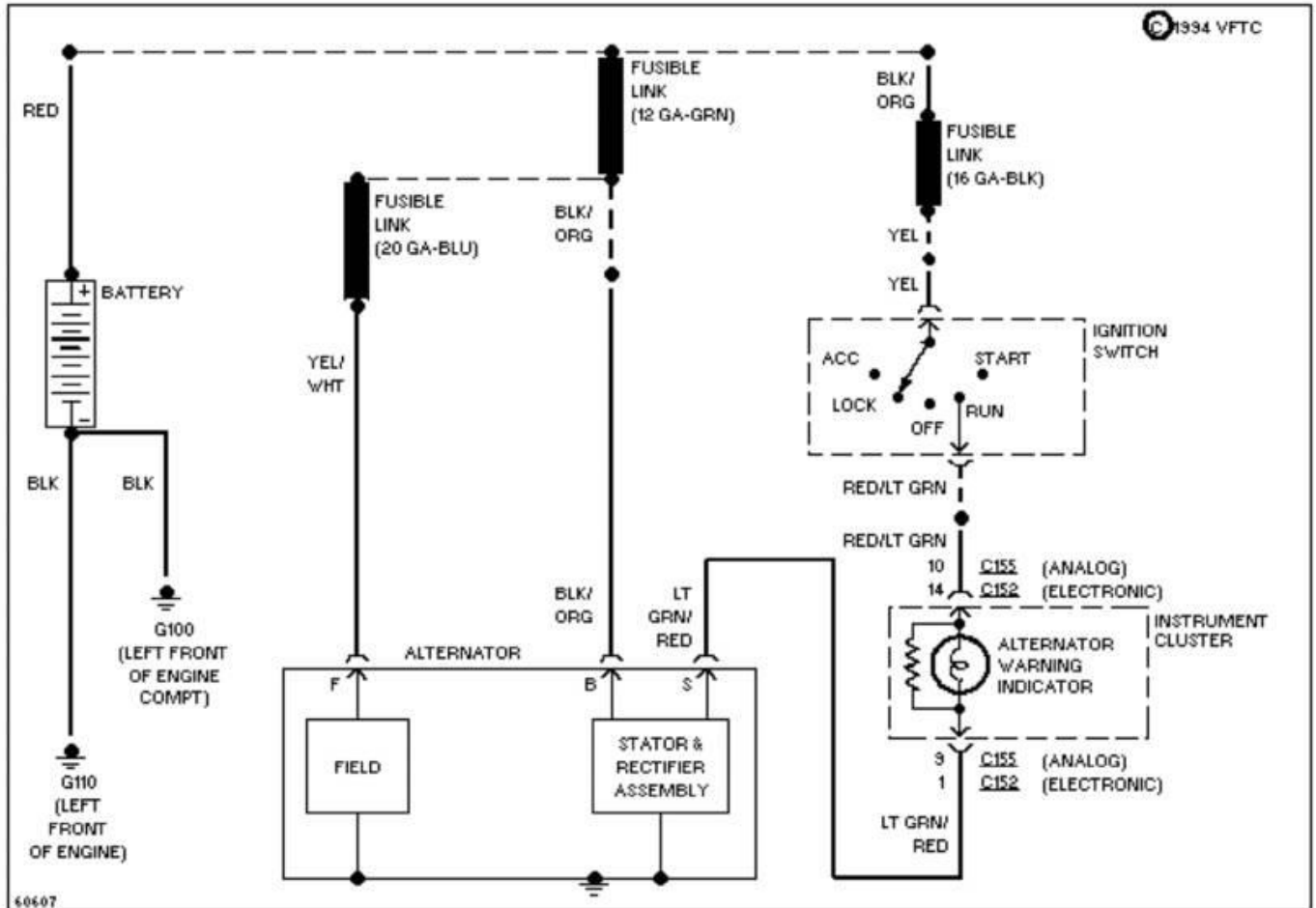

© 1994 VFTC

**1989 System Wiring Diagrams
Ford - Taurus**

PAVLIN

**Fig. 20: 3.0L, Charging Circuit, W/ Heated Windshield
1989 Ford Taurus LX**

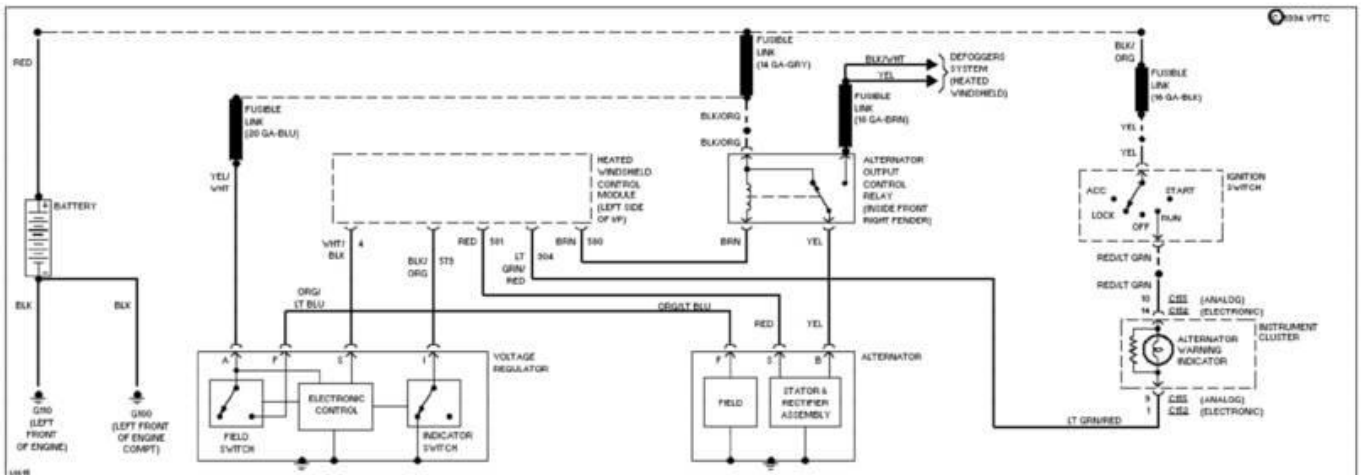

1989 System Wiring Diagrams
Ford - Taurus

PAVLIN

Fig. 21: 3.0L, Charging Circuit, W/O Heated Windshield
1989 Ford Taurus LX

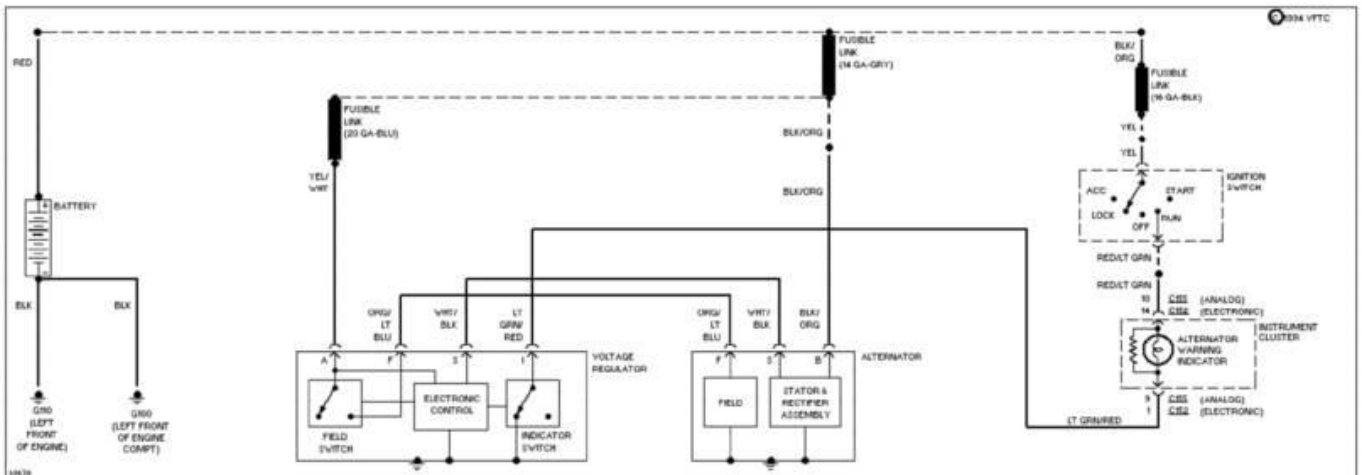

1989 System Wiring Diagrams
Ford - Taurus

PAVLIN

Fig. 22: Starting Circuit
1989 Ford Taurus LX

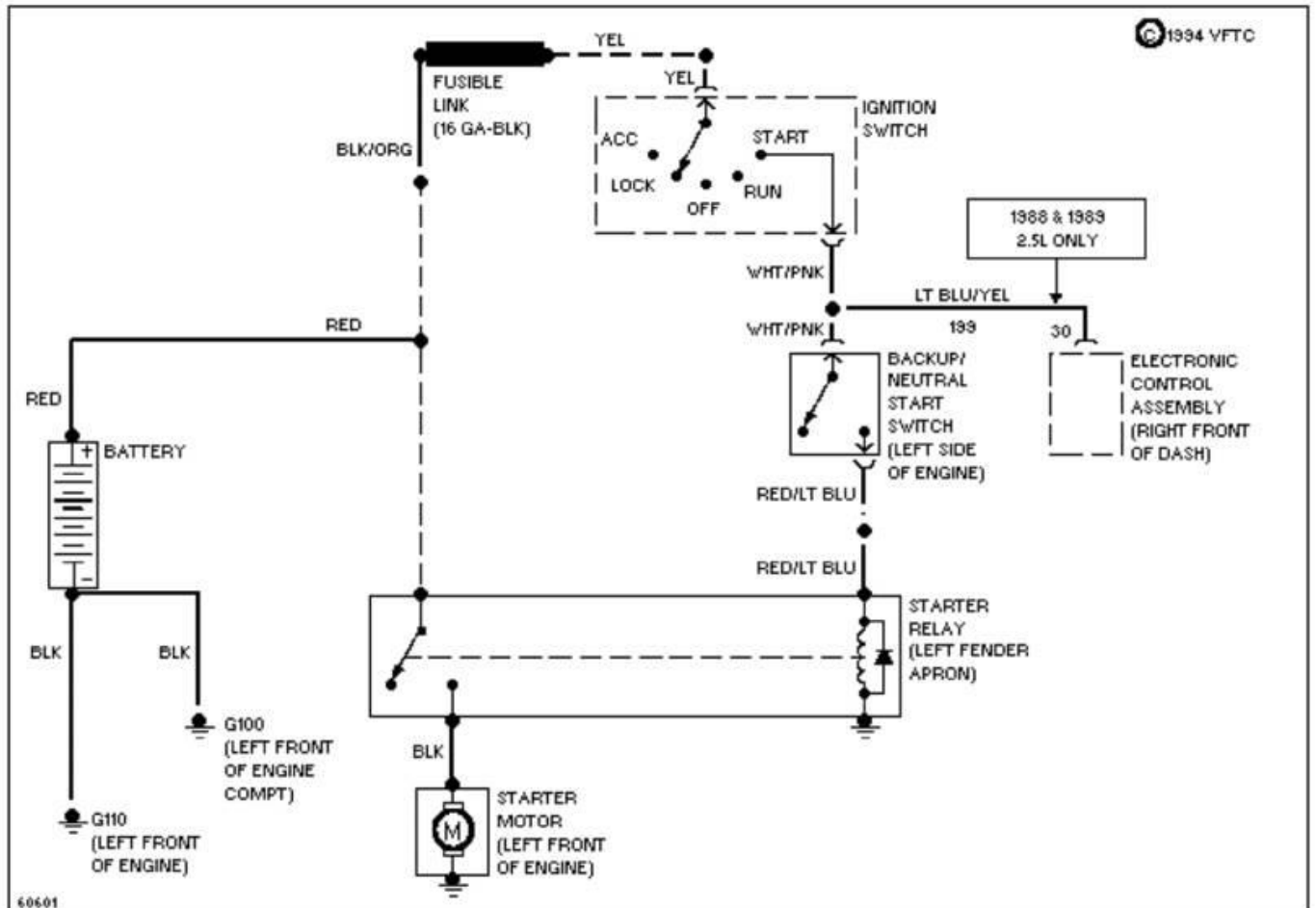

**1989 System Wiring Diagrams
Ford - Taurus**

PAVLIN

**Fig. 23: 3.8L, Charging Circuit, W/ Heated Windshield
1989 Ford Taurus LX**

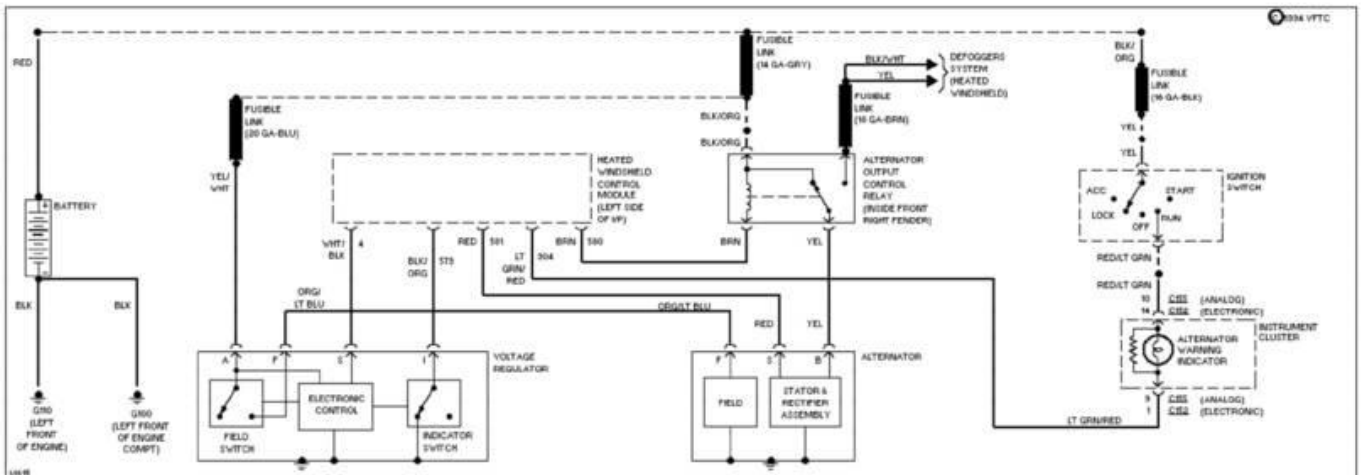

1989 System Wiring Diagrams
Ford - Taurus

PAVLIN

Fig. 24: 3.8L, Charging Circuit, W/O Heated Windshield
1989 Ford Taurus LX

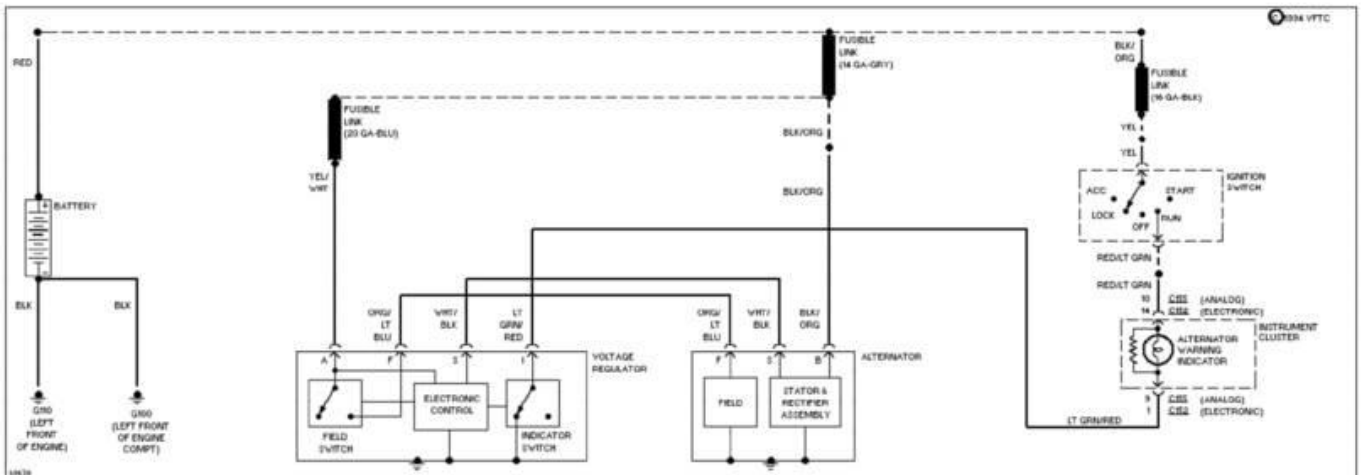

1989 System Wiring Diagrams
Ford - Taurus

PAVLIN

Fig. 25: Starting Circuit
1989 Ford Taurus LX

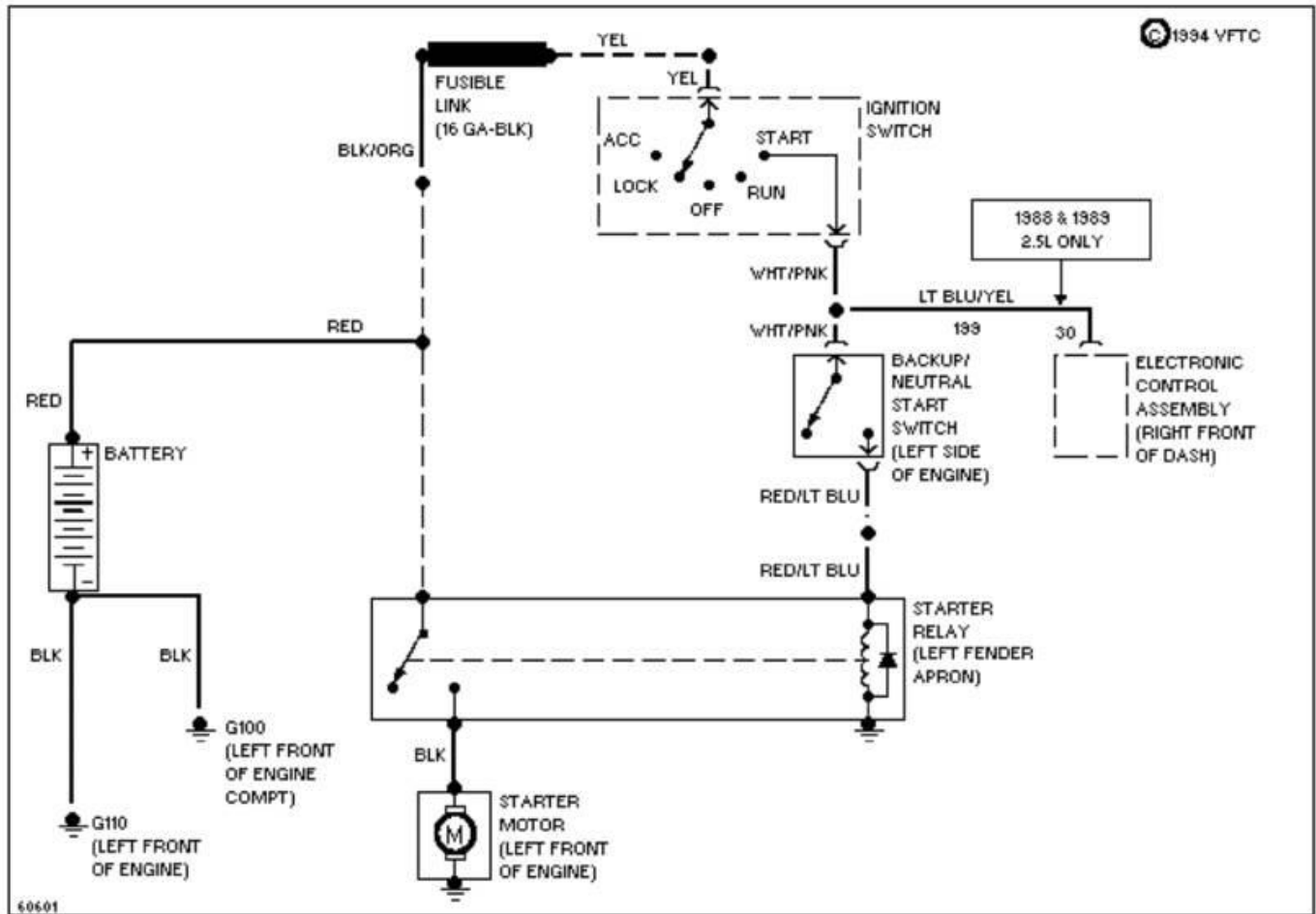

1989 System Wiring Diagrams
Ford - Taurus

PAVLIN

Fig. 26: Trunk Release Circuit
1989 Ford Taurus LX

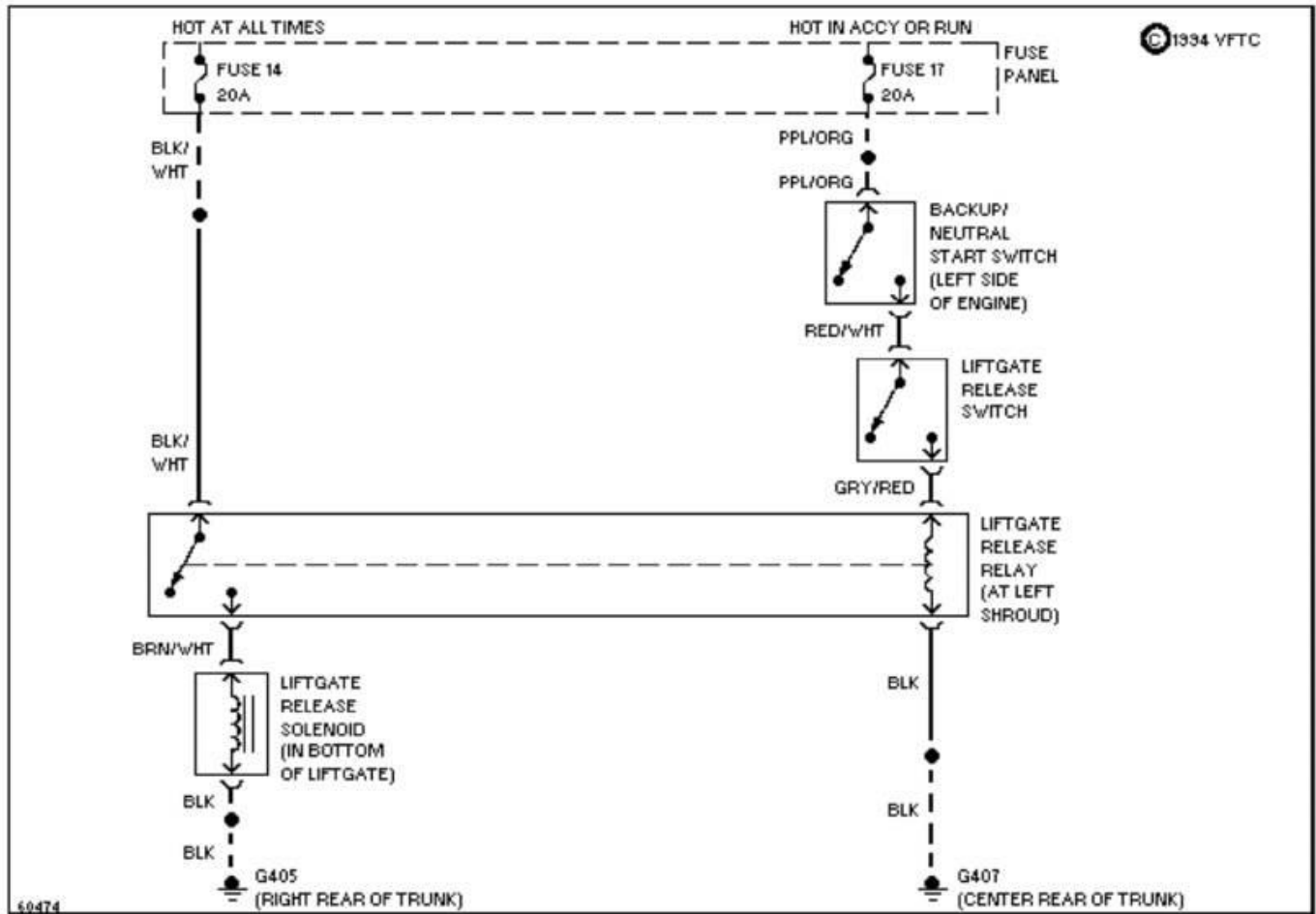

1989 System Wiring Diagrams
Ford - Taurus

PAVLIN

Fig. 27: Interval Wiper/Washer Circuit
1989 Ford Taurus LX

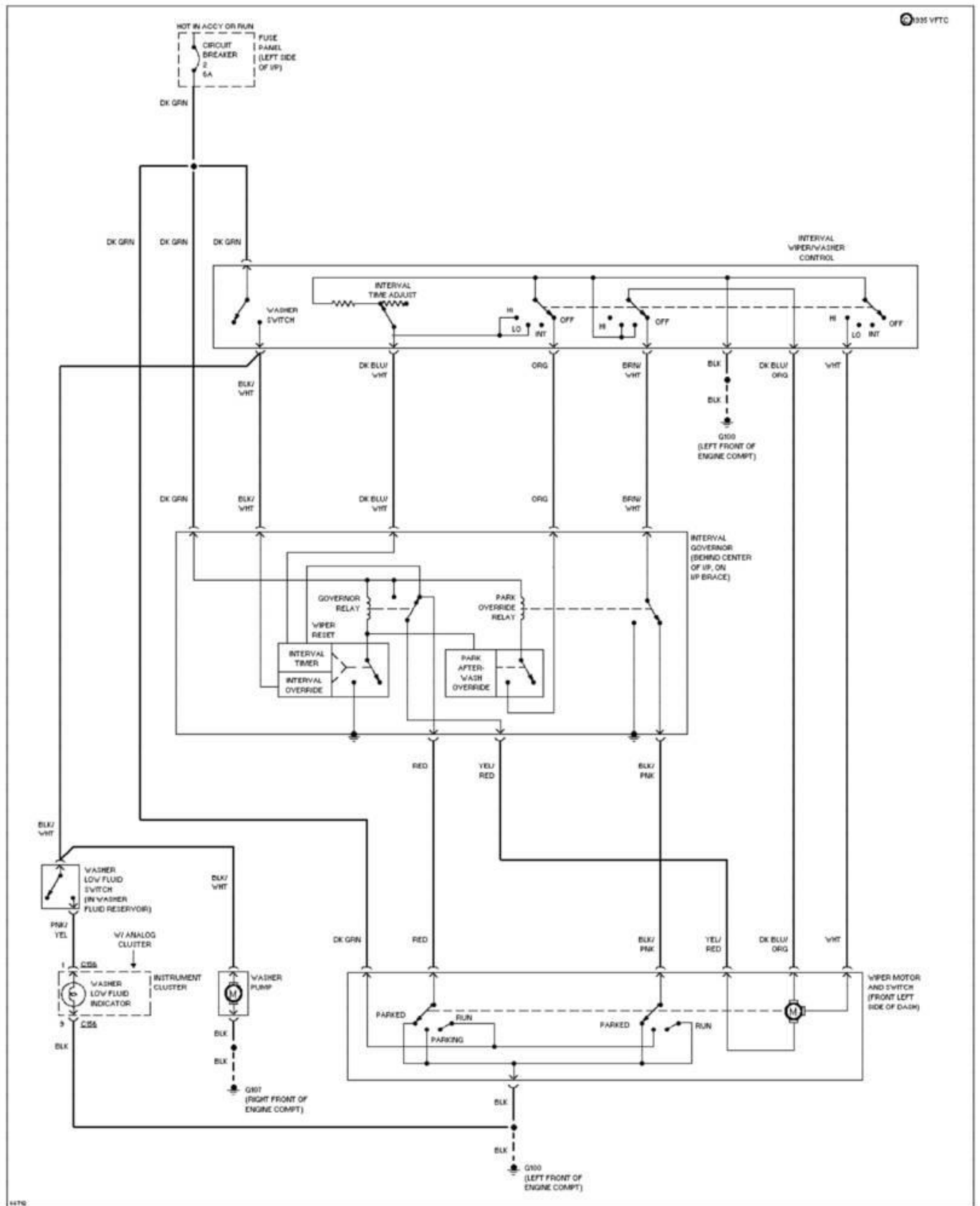

1989 System Wiring Diagrams
Ford - Taurus

PAVLIN

Fig. 28: Rear Wiper/Washer Circuit
1989 Ford Taurus LX

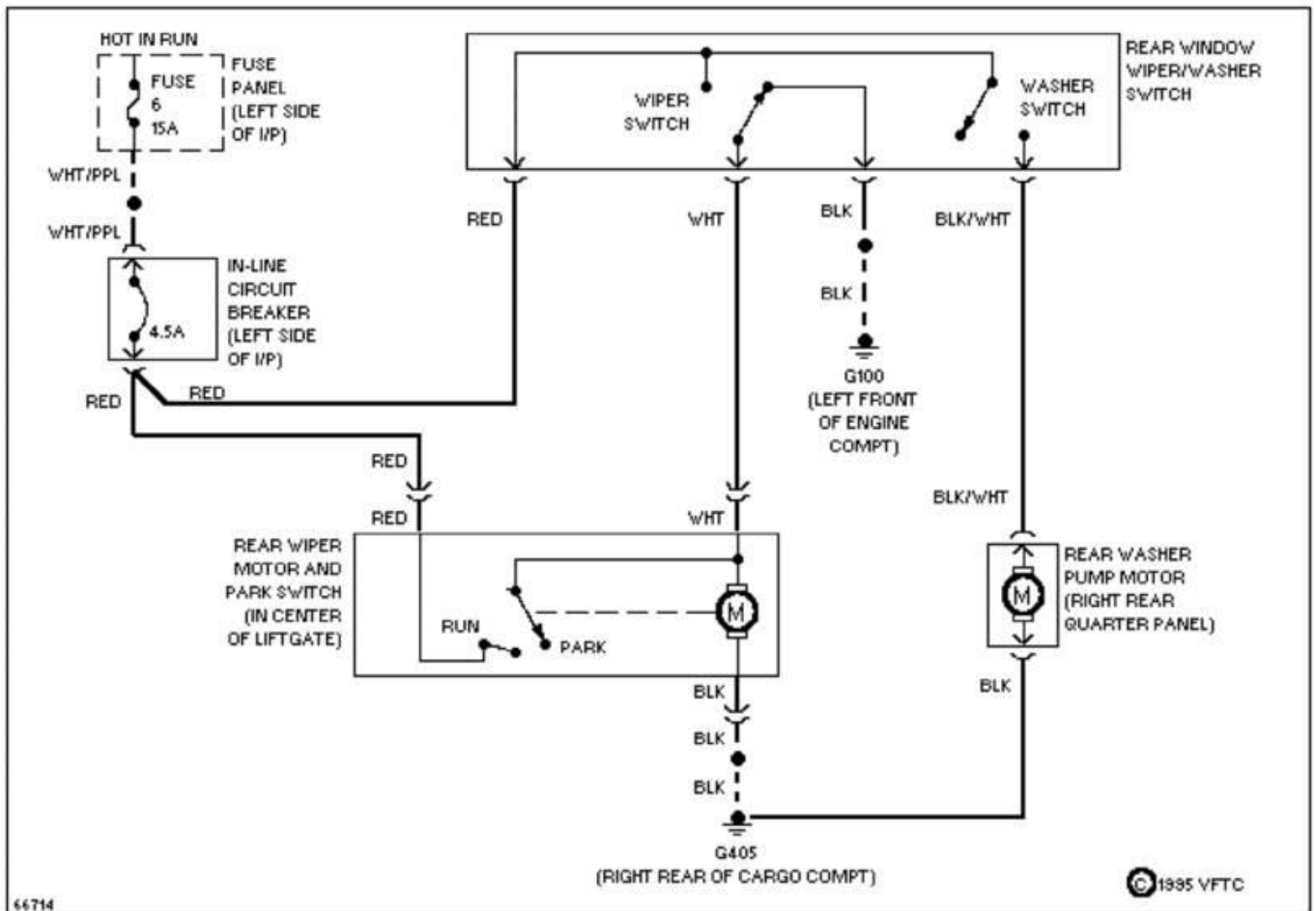

WIRING DIAGRAMS

1989 WIRING DIAGRAMS Ford Motor Co. Wiring Diagrams

PAVLIN

Fig. 1: Engine Compartment & Headlights
1989 Ford Taurus LX

COMPONENT LOCATOR:

A/C CLUTCH CYCLING SW	C 29, D 29
A/C HEATER FUNCTION SW	B-D 28
ALTERNATOR	B-D 3
ALT OUTPUT CONTROL RELAY	C-D 3
AUTO A/C (EATC) MODULE	A-B 26
AUTO LAMP DUAL RELAY	E 39
AUTO LAMP TIME CONTROL SW	E 31
BACK-UP LIGHT SW	C 49
BATTERY	A 1-2
BLOWER MOTOR	A 31, C 30
CHECK ENGINE IND	C 6, C 10, E 15, E 21
CG LIGHTER ASSEMBLY	C-D 39
CORNERING LTS (TAURUS)	A 1, E 1
CRUISE CONTROL SERVO	E 24
CRUISE CONTROL SW	E 34
DIAGNOSTIC WARNING MODULE	B-C 32
DIGITAL CLOCK	D 36
DISTRIBUTOR	C 7, C 11, C 21
DISTRIBUTORLESS IGNITION SYSTEM (DIS) MODULE	C-D 12-13
DOOR AJAR SWS	A-B 48
DOOR COURTESY LTS	B 39
DOOR LOCK SWS	A 44, A 47
DOOR SWS	A 36-37
ELECT CLUSTER SW ASSEMBLY	A-B 40
ELECT CONTROL ASSEMBLY (ECA) 2.5L	B-E 4
ELECT CONTROL ASSEMBLY (ECA) 3.0L EFI	B-E 8
ELECT CONTROL ASSEMBLY (ECA) 3.0L SHO	A 12-15
ELECT CONTROL ASSEMBLY (ECA) 3.8L	A 20-23
ELECT FLASHER	C 34-35
ENGINE COMPT LT	E 2
FOG LTS	B-D 1
FOG LIGHT SW	A 32
FUEL INJECTORS	E 5, E 10, E 13, C 21
FUSE BLOCK	C-D 25-26
FUS LINK (BATTERY)	A 2
FUS LINK (ALTERNATOR)	B-C 2
FUS LINK (ALT OUTPUT CONTROL RELAY)	C 3
FUS LINK (IGNITION SW)	B 26
FUS LINK (STARTER RELAY)	A 2-3
GLOVE COMPT SW & LT	B-C 37
HEATED EXHAUST GAS OXYGEN (HEGO) SENSOR #1	D 6, D 10, E 14, E 22
HEATED EXHAUST GAS OXYGEN (HEGO) SENSOR #2	E 14, E 22
HEATED WINDSHIELD CONTROL MODULE	C 31
HEATED WINDSHIELD SW	B-C 31
HORNS	C 1
HORN RELAY	C 1
IGNITION COIL	B 7, B 11, D-E 12, D 20
IGNITION SW	A-C 24
ILLUMINATION DIMMING RELAY	C 39
ILLUMINATED ENTRY TIMER	B-C 37
INST CLSTR (ANALOG)	A-D 43
INST CLSTR (ELECT)	A-E 41-42
INTEGRATED CONTROL MODULE (ICM) 2.5L	A-B 7
INTEGRATED CONTROL MODULE (ICM) 3.0L EFI	A-B 11
INTEGRATED CONTROL MODULE (ICM) 3.0L SHO	A 18-19
INTEGRATED CONTROL MODULE (ICM) 3.8L	E 16-17
INTERVAL GOVERNOR	D 32-33
KEYLESS ENTRY MODULE	B-C 47
LCD DIMMING RELAY	D-E 38
LIFTGATE AJAR SW	A 48
LIFTGATE RELEASE RELAY	E 49
LIFTGATE RELEASE SW	E 49-50
LIGHT SENSOR/AMPLIFIER	D-E 31
MAIN LIGHT SWITCH	D-E 38
MOON ROOF CONTROL SW	C 48
NEUTRAL SAFETY/BACK-UP LIGHT SWITCH	A-B 27
POWER ANTENNA SW	D 48
POWER MIRROR SW	E 48-47
POWER SEAT CONTROL SW	D 44-46
POWER WINDOW SAFETY RELAY	A-B 44
RADIO	C-D 36
REAR COURTESY LTS	A-B 38
REAR WINDOW DEFOGGER CONTROL	C-D 34
SELF TEST INPUT (STI) CONN	E 6, E 10, E 15, E 23
SELF TEST OUTPUT (STO) CONN	C 6, C 11, E 14-15, E 21-22
SPEED SENSOR	B 4, A 8, A 20
SPOUT CONN	B 6, B 10, B 12, C 20
STARTER RELAY	A 2
STOP LIGHT SWITCH	C 35
TFI MODULE	C 7, C 11, C-D 21
TOP GEAR SW (M/T)	E 5
UPSHIFT DIMMER RELAY (M/T)	E 25-26
VOLTAGE REGULATOR	C 1, D 2
WARNING CHIME MODULE	E 28, E 20
WASHER FLUID LEVEL SW	E 2
WIPER MOTOR (FRONT)	E 3
WIPER/WASHER SW (FRONT)	E 32-33
WIPER/WASHER SW (REAR)	E 48

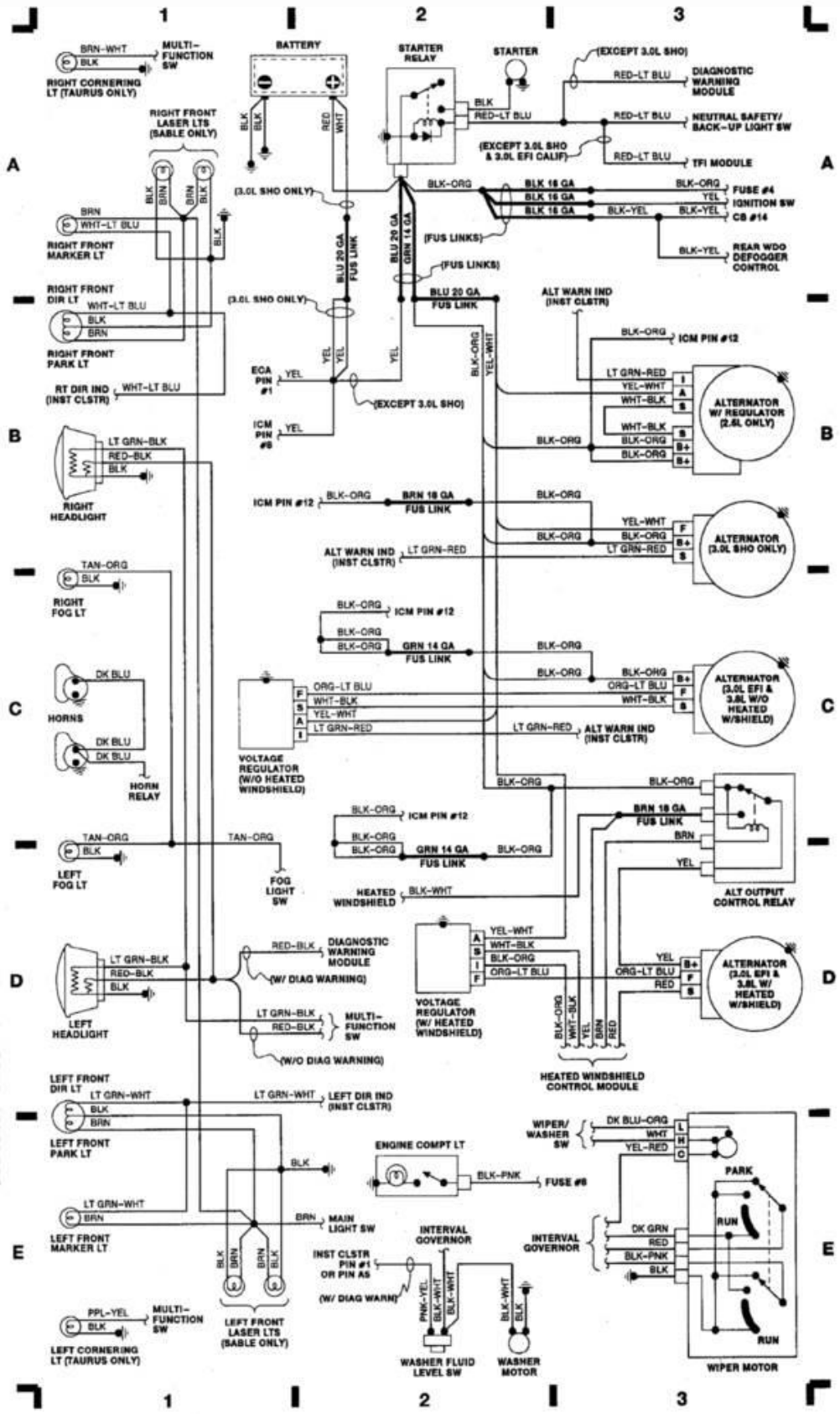

113099

WIRING DIAGRAMS

1989 WIRING DIAGRAMS Ford Motor Co. Wiring Diagrams

PAVLIN

Fig. 2: Computer Engine Control (2.5L)
1989 Ford Taurus LX

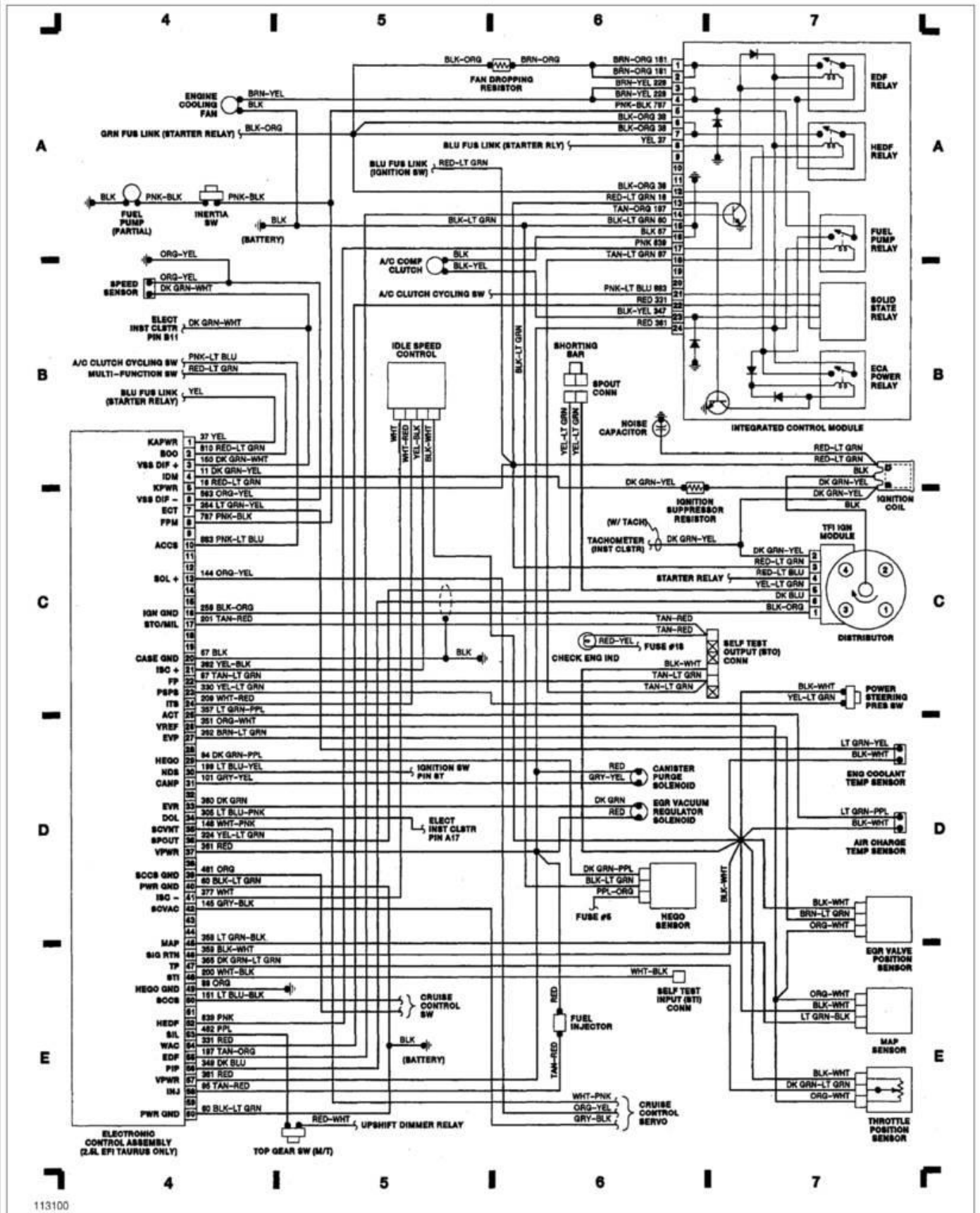

WIRING DIAGRAMS

1989 WIRING DIAGRAMS Ford Motor Co. Wiring Diagrams

PAVLIN

Fig. 3: Computer Engine Control (3.0L EFI)
1989 Ford Taurus LX

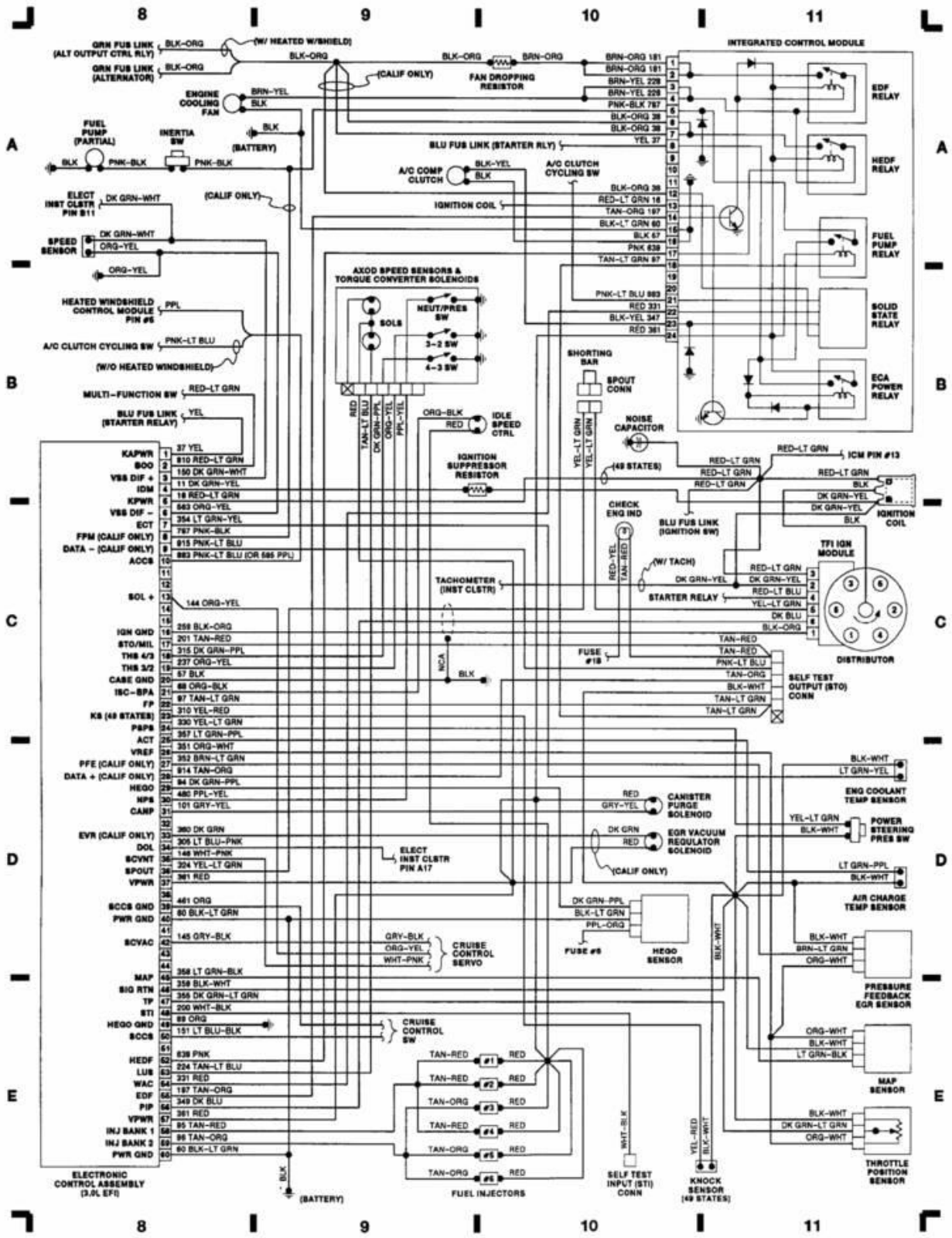

50D01685

WIRING DIAGRAMS
1989 WIRING DIAGRAMS Ford Motor Co. Wiring Diagrams

PAVLIN

Fig. 4: Computer Engine Control (3.0L SHO)
1989 Ford Taurus LX

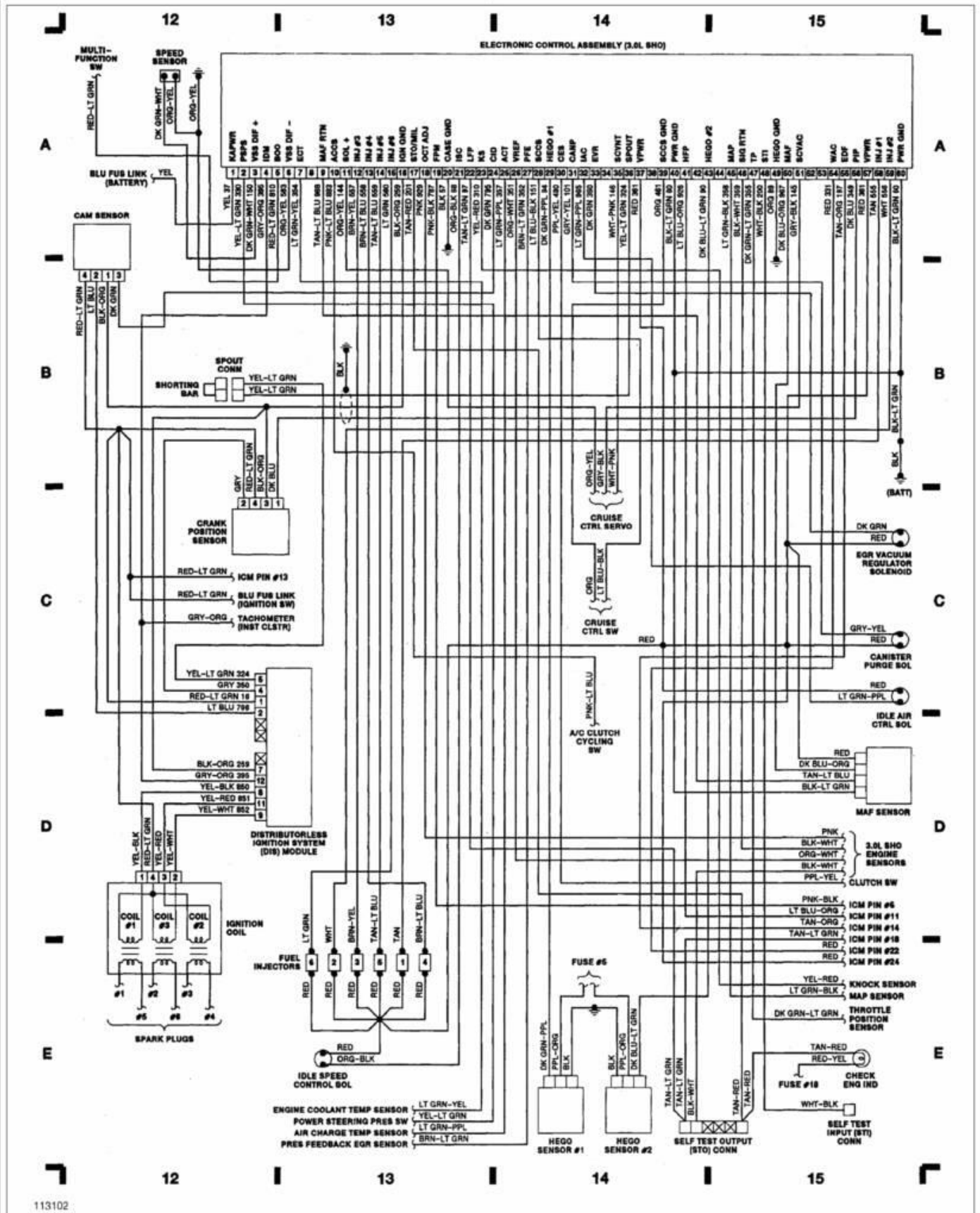

WIRING DIAGRAMS

1989 WIRING DIAGRAMS Ford Motor Co. Wiring Diagrams

PAVLIN

Fig. 5: Engine Control Sensors
1989 Ford Taurus LX

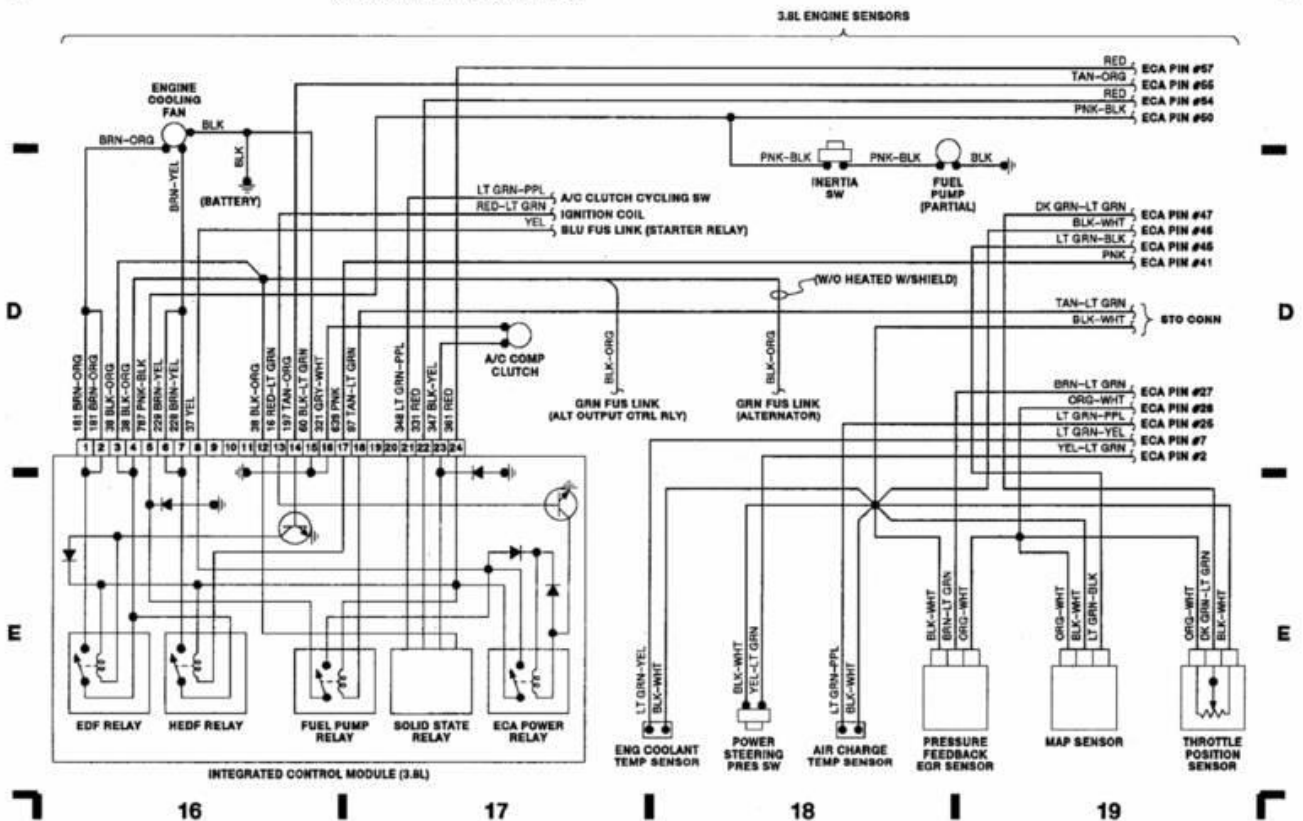
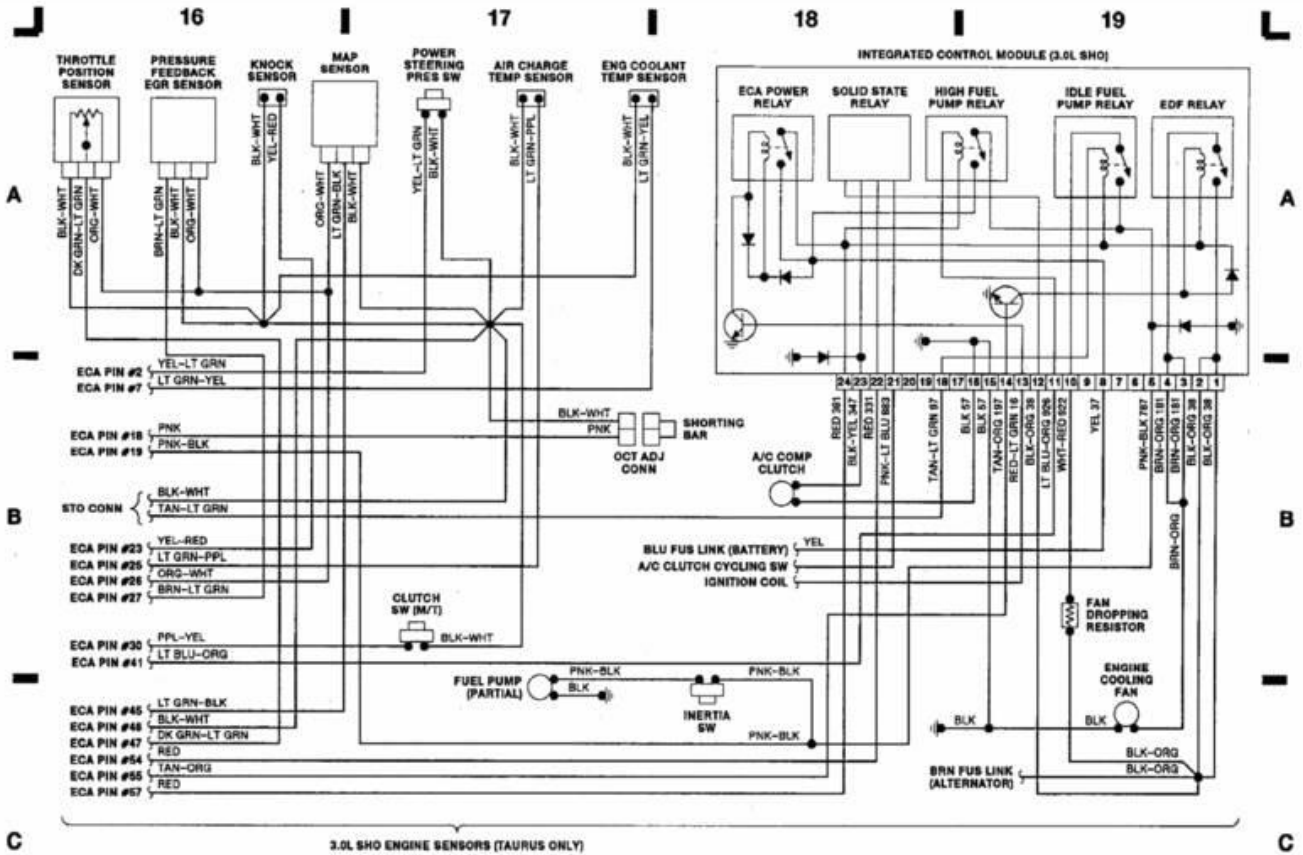

113103

WIRING DIAGRAMS

1989 WIRING DIAGRAMS Ford Motor Co. Wiring Diagrams

PAVLIN

Fig. 6: Computer Engine Control (3.8L)
1989 Ford Taurus LX

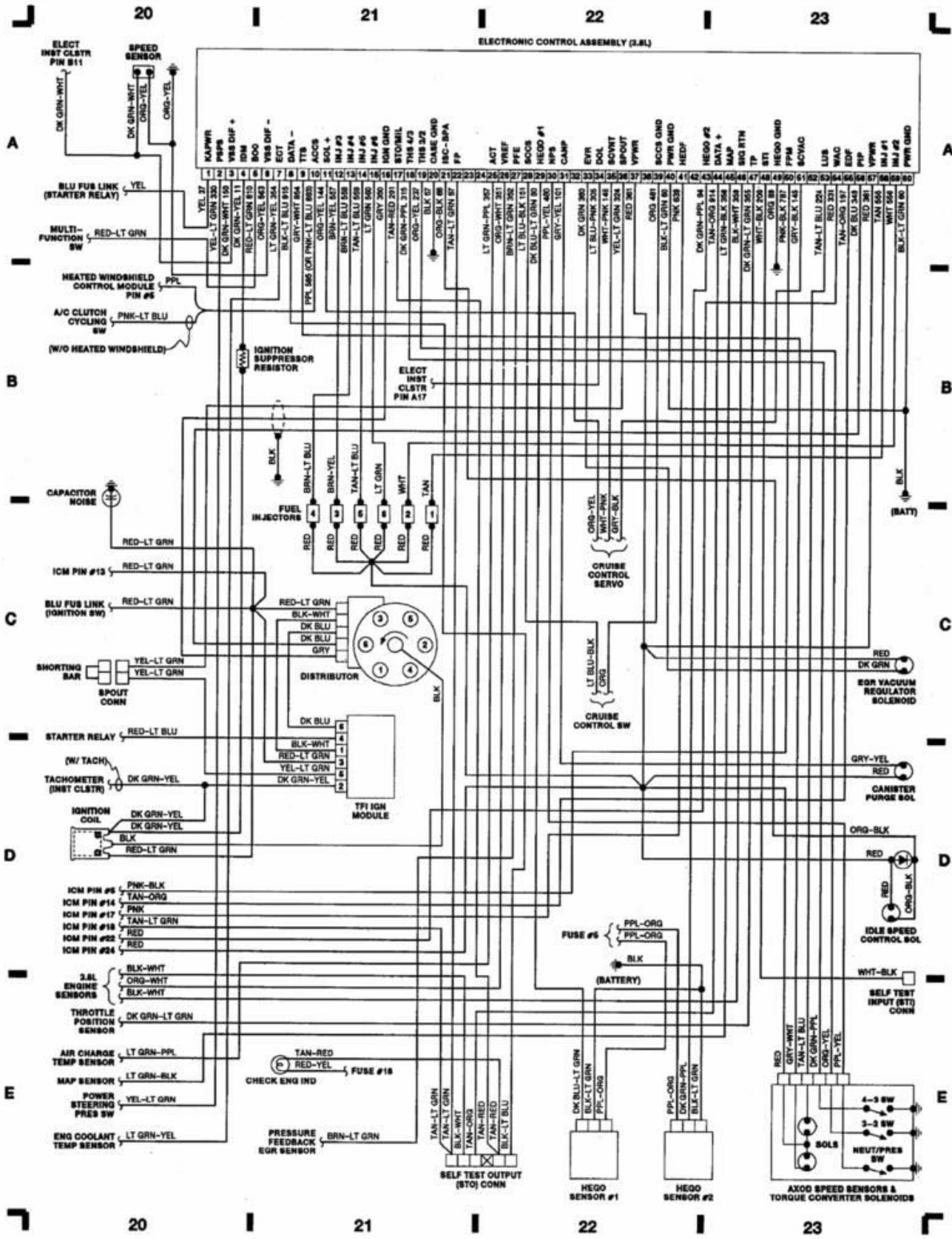

113104

WIRING DIAGRAMS

1989 WIRING DIAGRAMS Ford Motor Co. Wiring Diagrams

PAVLIN

Fig. 7: Fuse Block
1989 Ford Taurus LX

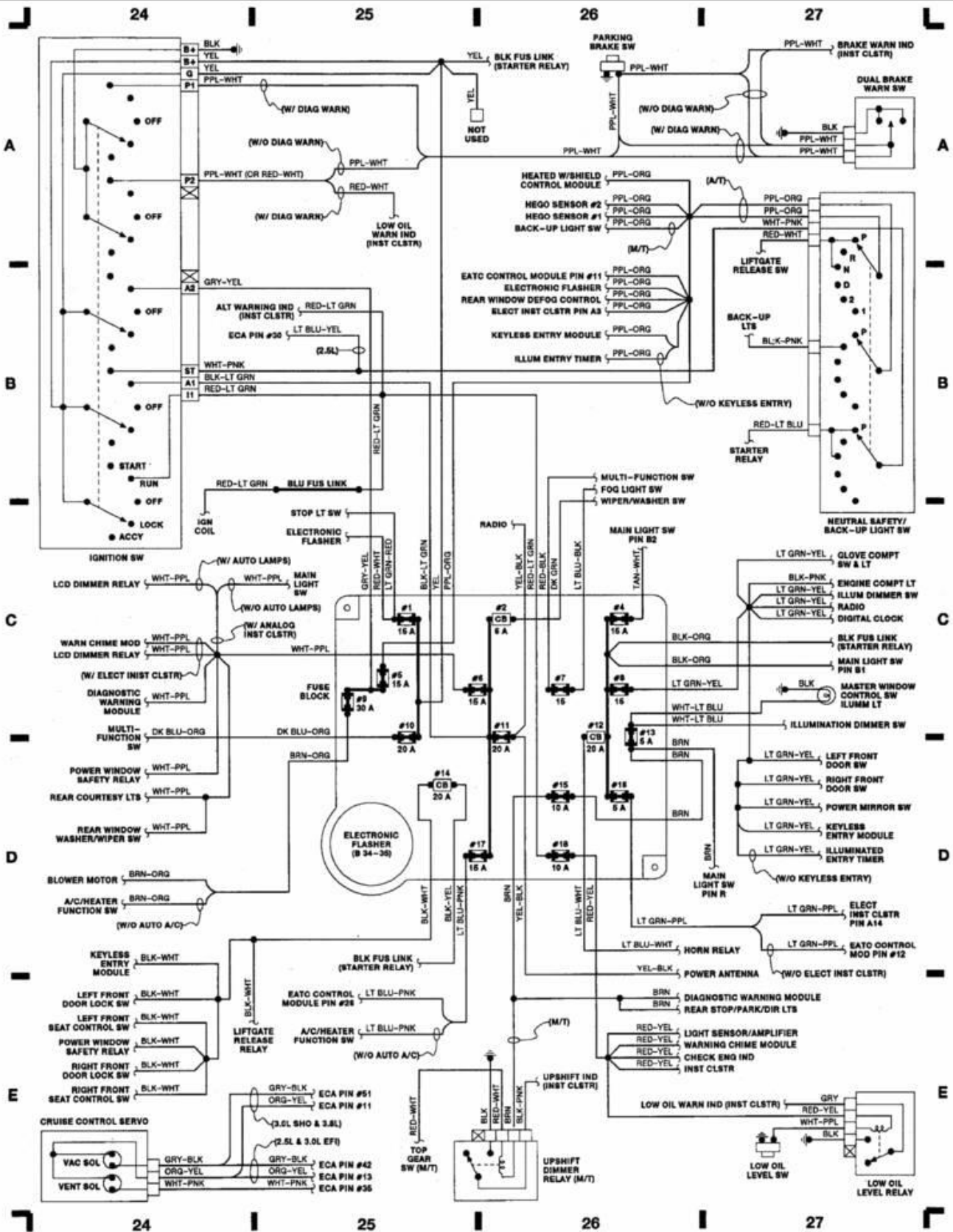

113105

WIRING DIAGRAMS

1989 WIRING DIAGRAMS Ford Motor Co. Wiring Diagrams

PAVLIN

Fig. 8: A/C & Heater
1989 Ford Taurus LX

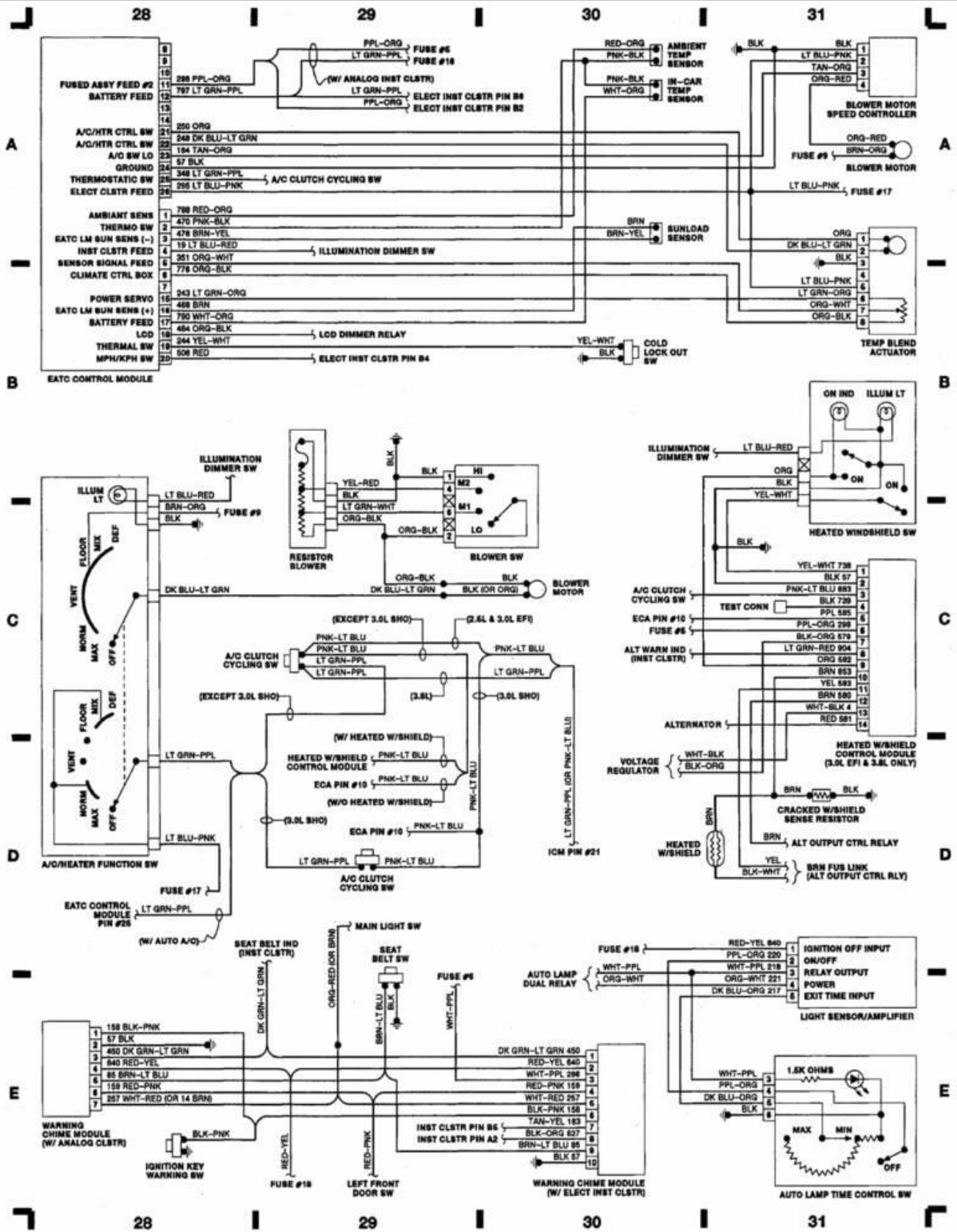

113106

WIRING DIAGRAMS

1989 WIRING DIAGRAMS Ford Motor Co. Wiring Diagrams

PAVLIN

Fig. 9: Multi-Function Switch, Wiper/Washer System & Diagnostic Module
1989 Ford Taurus LX

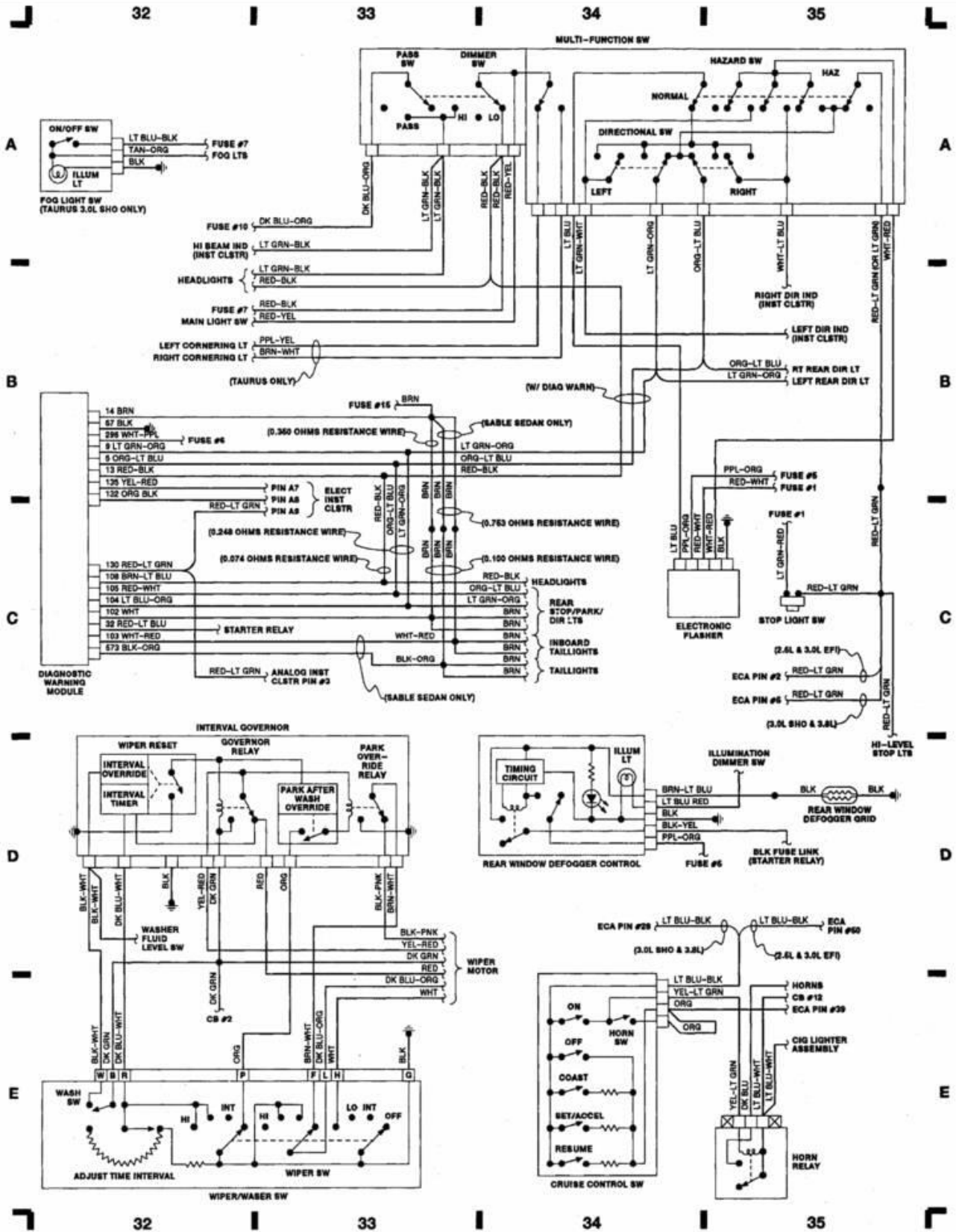

113107

WIRING DIAGRAMS
1989 WIRING DIAGRAMS Ford Motor Co. Wiring Diagrams

PAVLIN

Fig. 10: Accessories
 1989 Ford Taurus LX

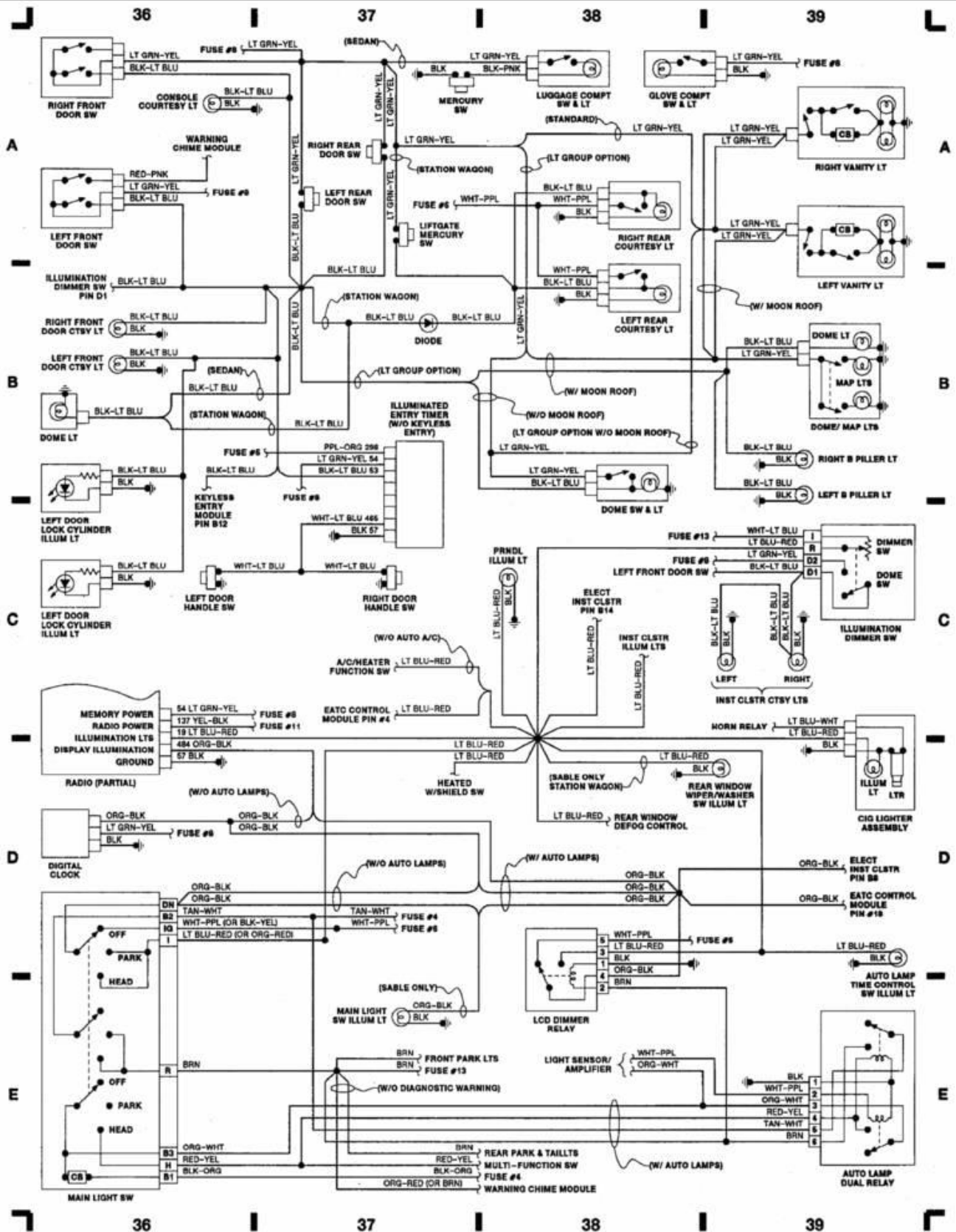

113108

WIRING DIAGRAMS

1989 WIRING DIAGRAMS Ford Motor Co. Wiring Diagrams

PAVLIN

Fig. 11: Instrument Panel
1989 Ford Taurus LX

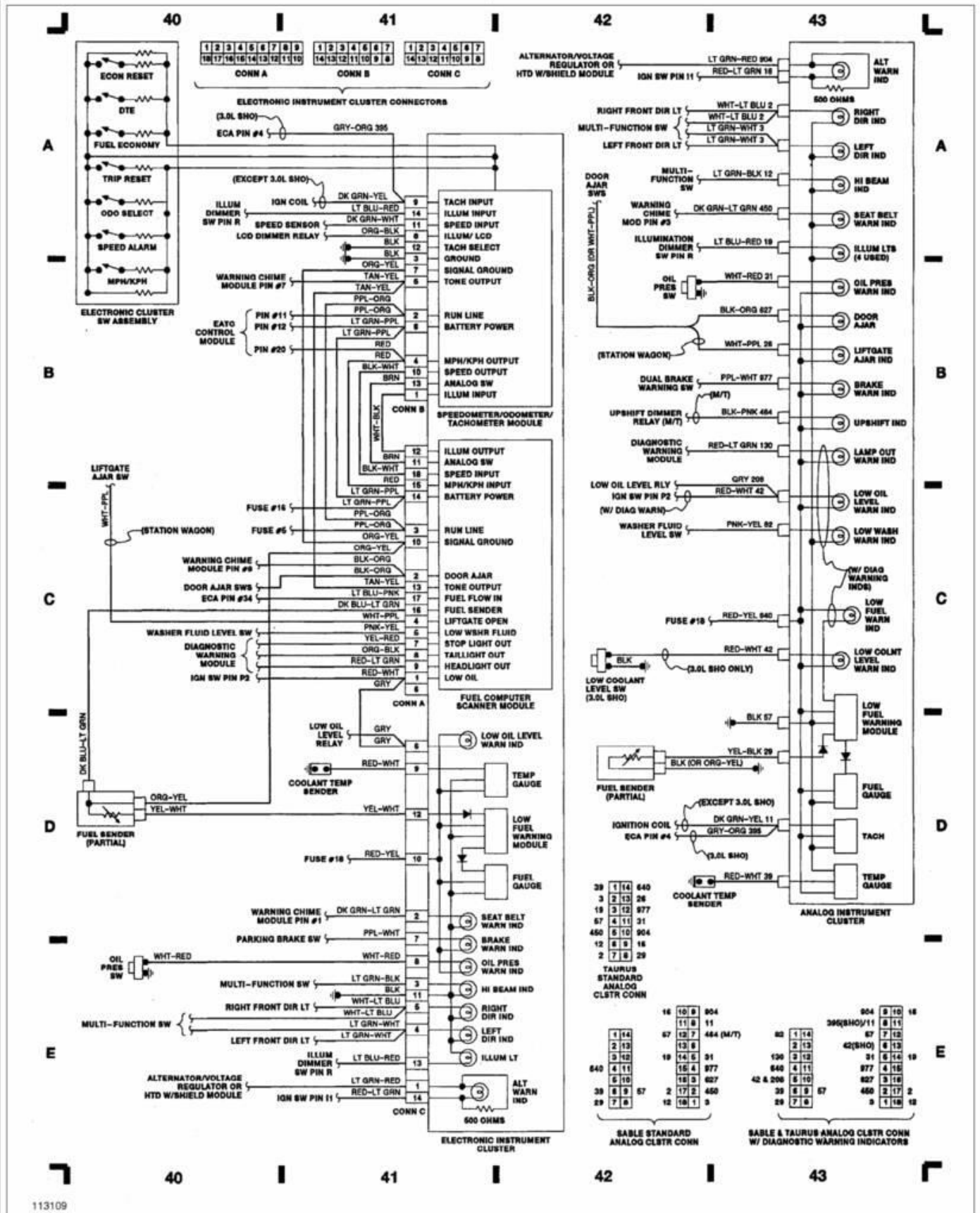

WIRING DIAGRAMS

1989 WIRING DIAGRAMS Ford Motor Co. Wiring Diagrams

PAVLIN

Fig. 12: Passenger Compartment
1989 Ford Taurus LX

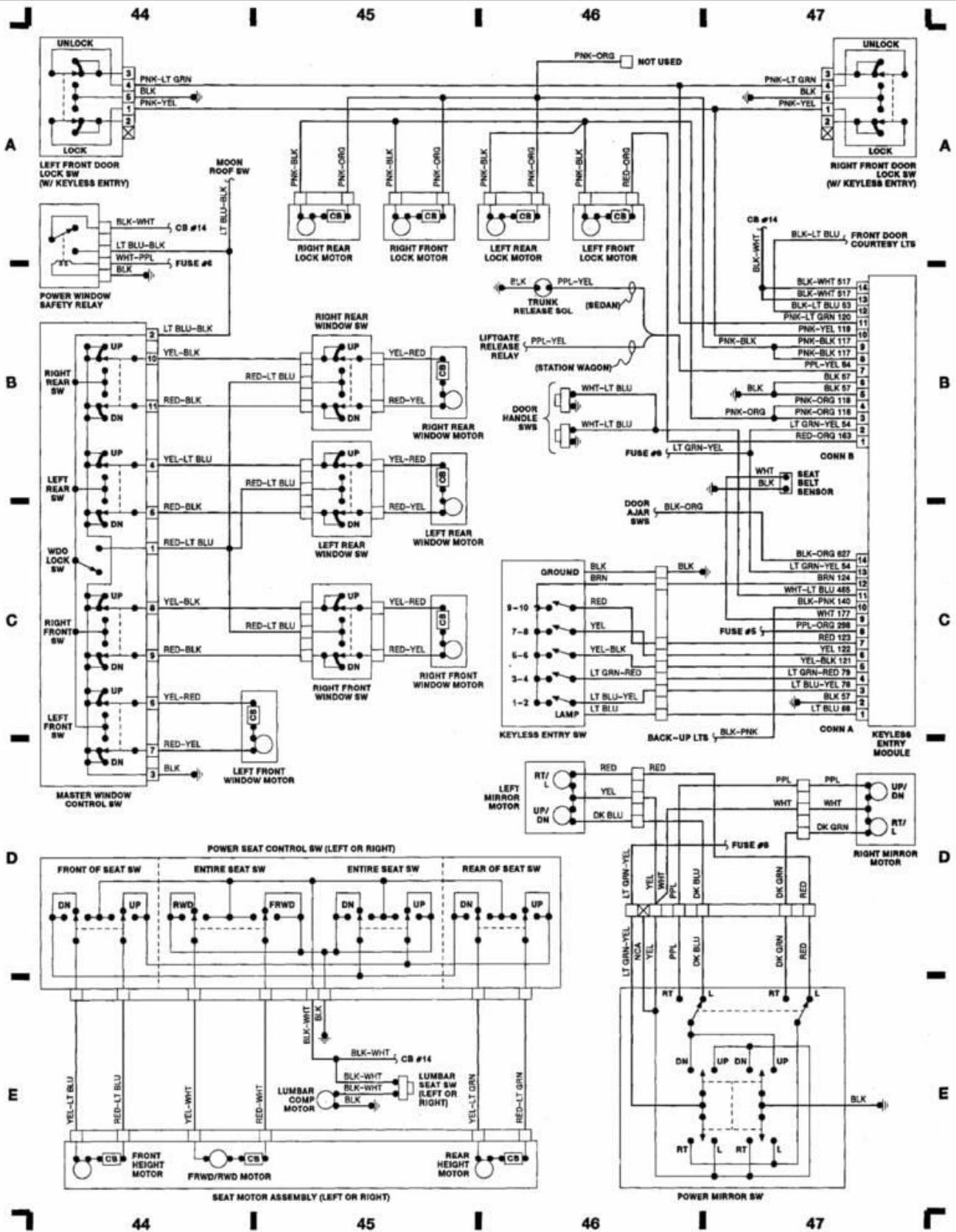

113110

WIRING DIAGRAMS

1989 WIRING DIAGRAMS Ford Motor Co. Wiring Diagrams

PAVLIN

Fig. 13: Passenger Compartment (Cont.) & Taillights
1989 Ford Taurus LX

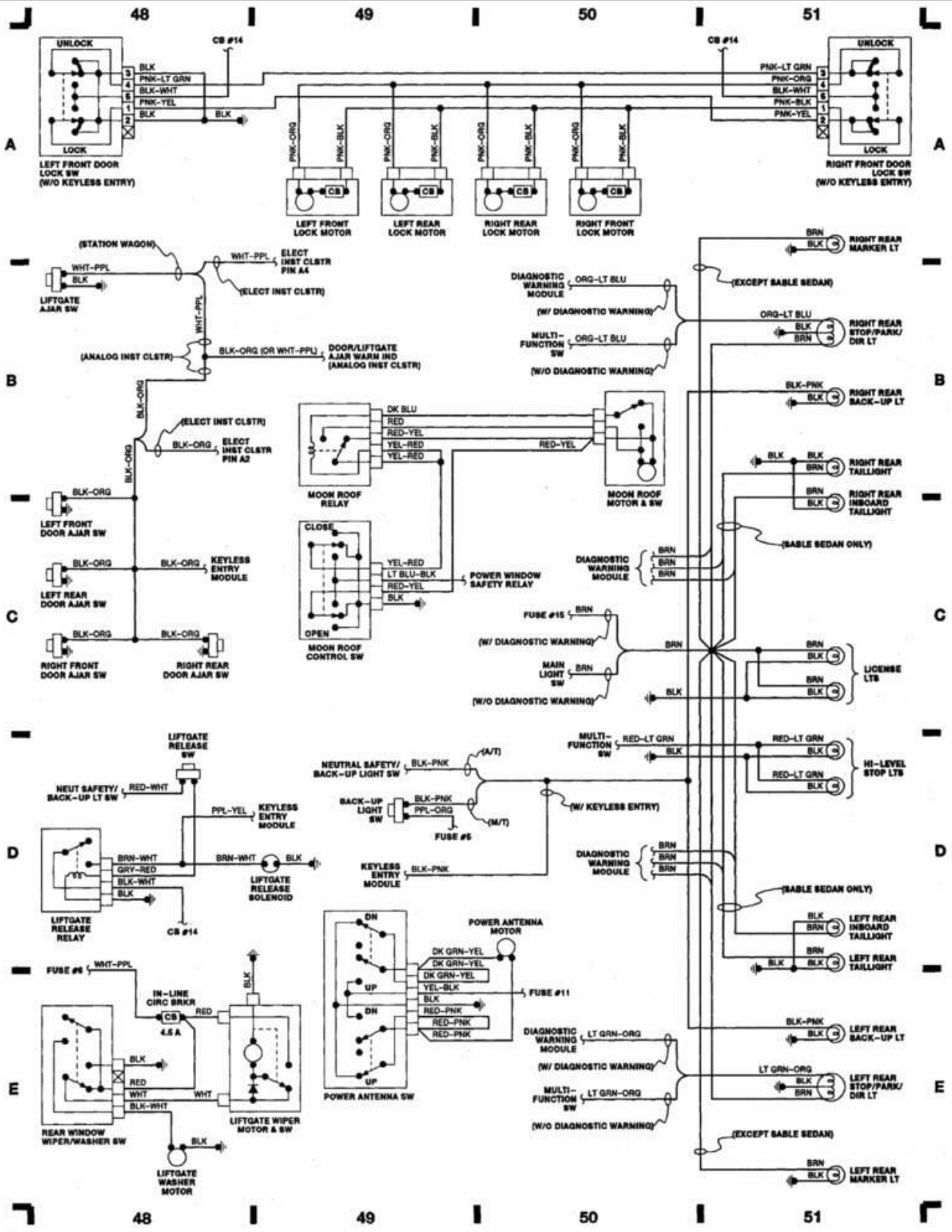

113111