

**1990 System Wiring Diagrams
Ford - Taurus**

PAVLIN

Fig. 1: 2.5L, Cooling Fan Circuit
1990 Ford Taurus LX

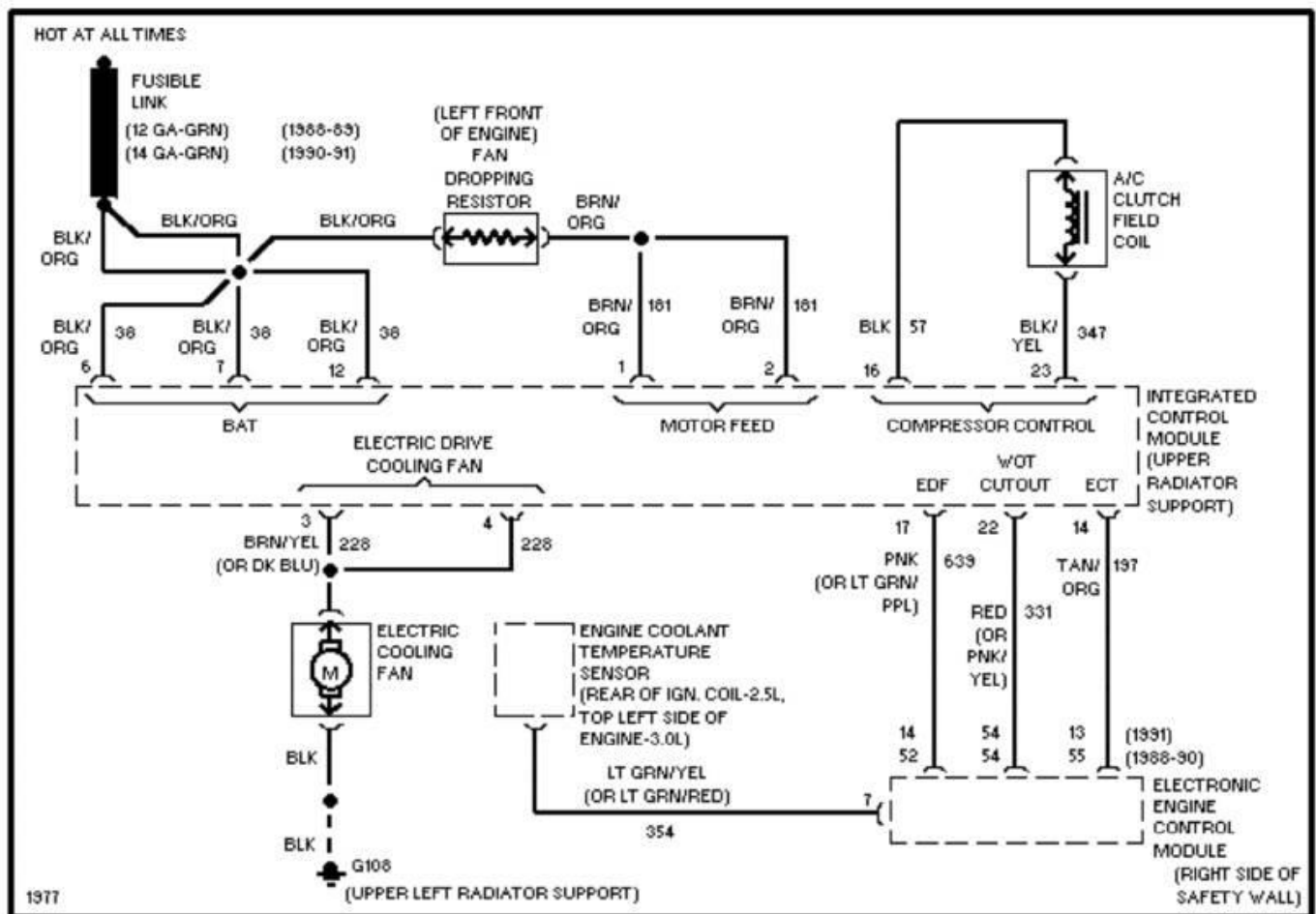

1990 System Wiring Diagrams
Ford - Taurus

PAVLIN

Fig. 2: 3.0L SHO, Cooling Fan Circuit
1990 Ford Taurus LX

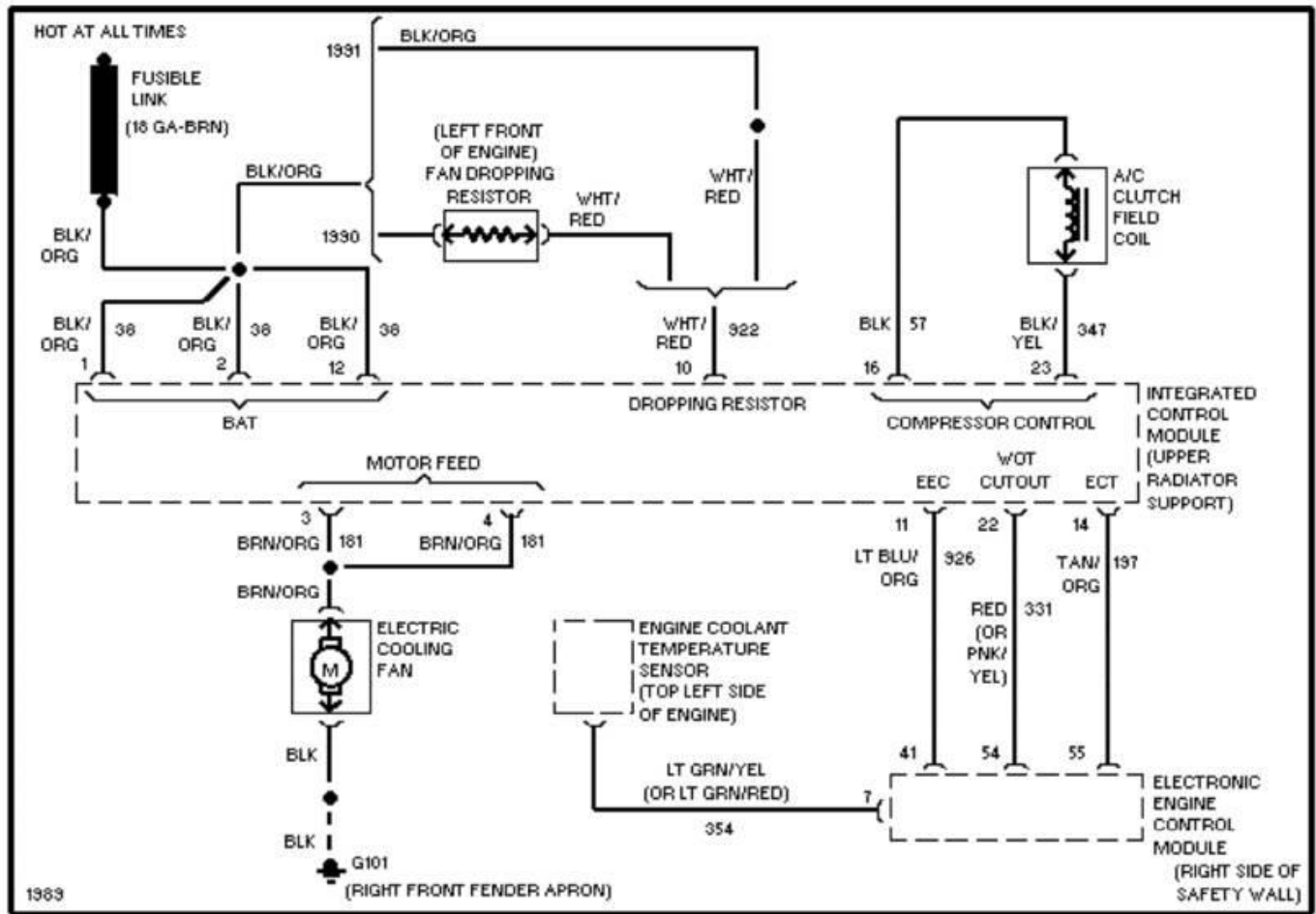

1990 System Wiring Diagrams
Ford - Taurus

PAVLIN

Fig. 3: 3.0L, Cooling Fan Circuit
1990 Ford Taurus LX

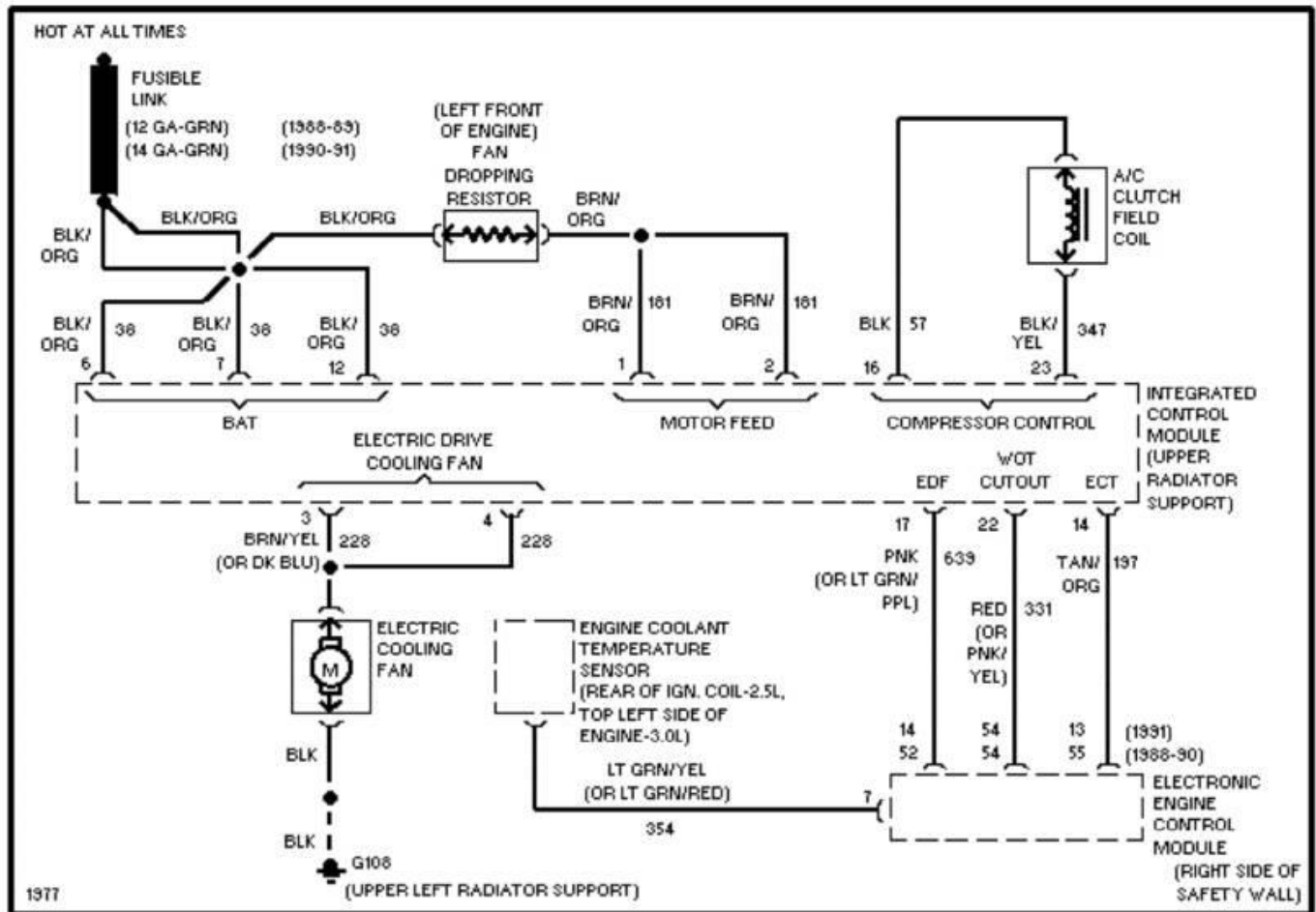

1977

1990 System Wiring Diagrams
Ford - Taurus

PAVLIN

Fig. 4: 3.8L, Cooling Fan Circuit
1990 Ford Taurus LX

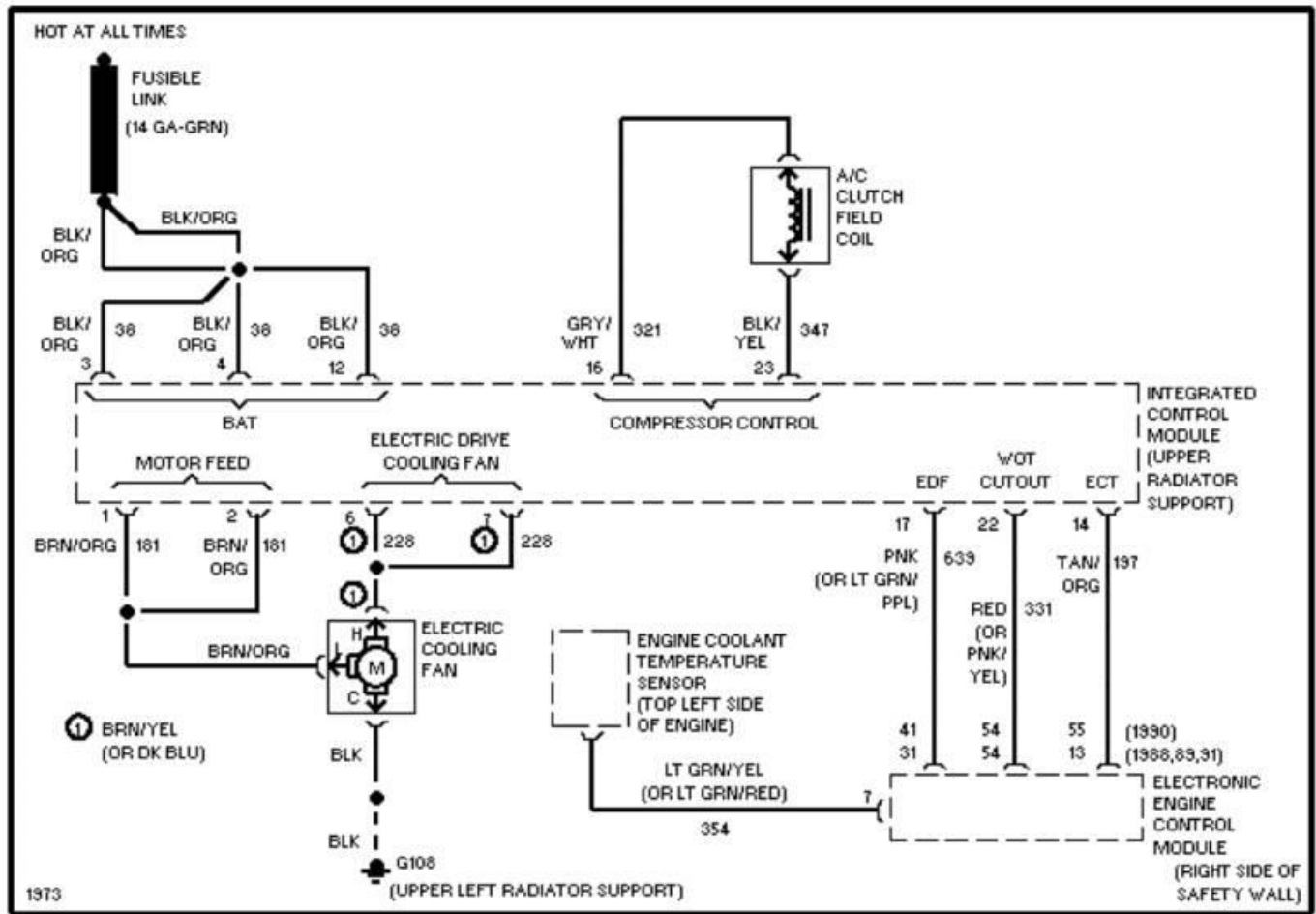

1990 System Wiring Diagrams Ford - Taurus

PAVLIN

Fig. 5: Defogger Circuit
1990 Ford Taurus LX

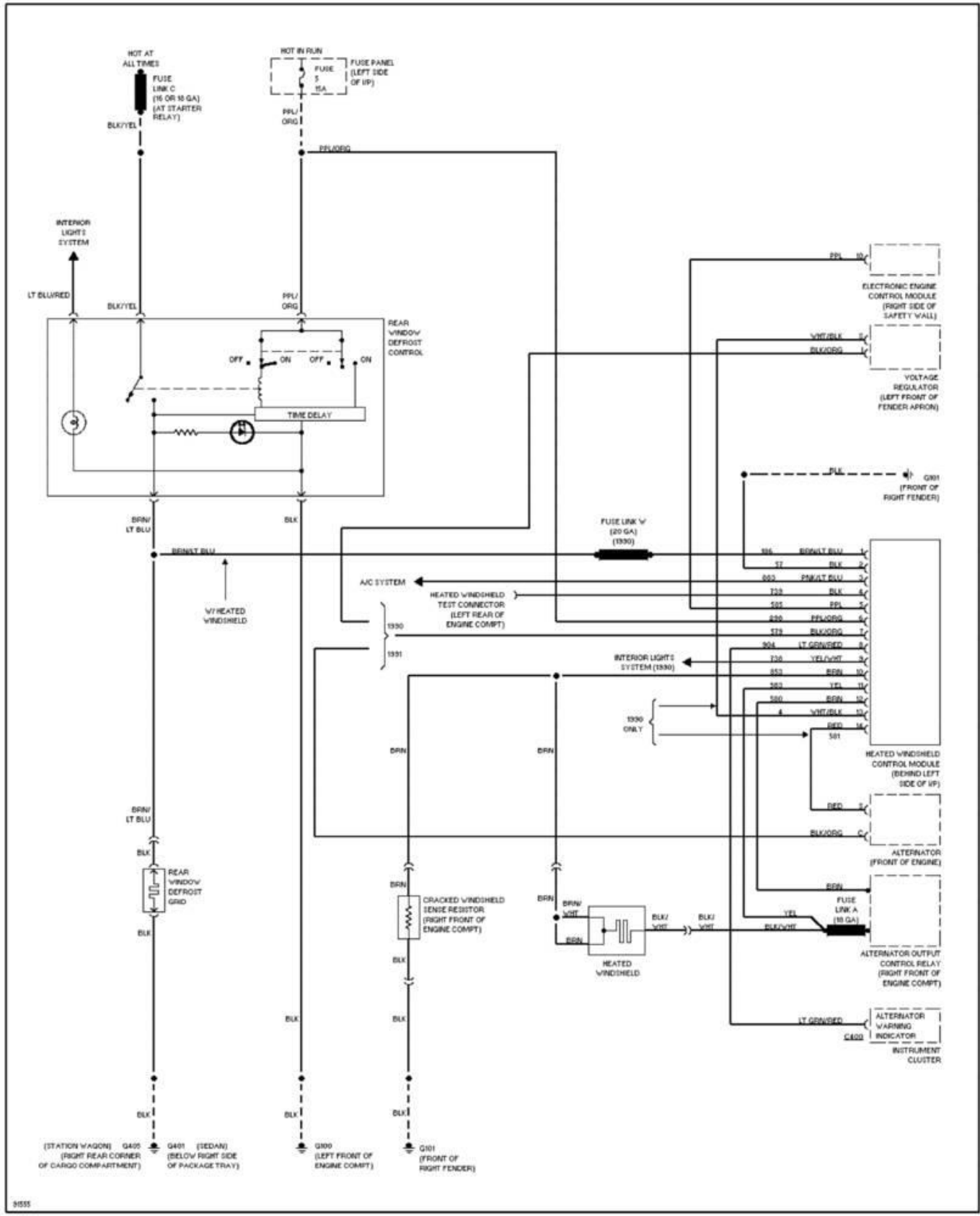

1990 System Wiring Diagrams
Ford - Taurus

PAVLIN

Fig. 6: Horn Circuit
1990 Ford Taurus LX

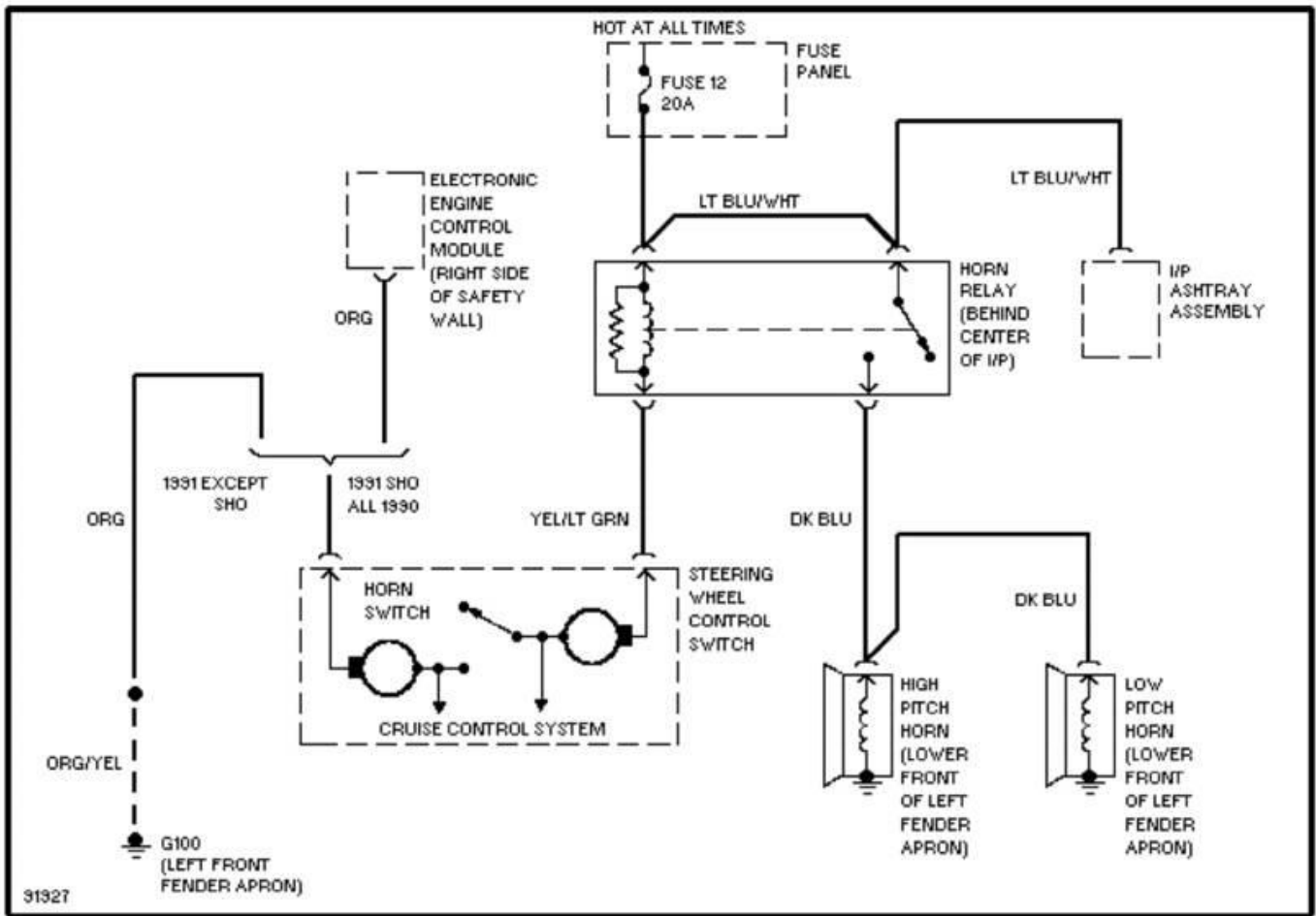

1990 System Wiring Diagrams
Ford - Taurus

PAVLIN

Fig. 7: Power Antenna Circuit
1990 Ford Taurus LX

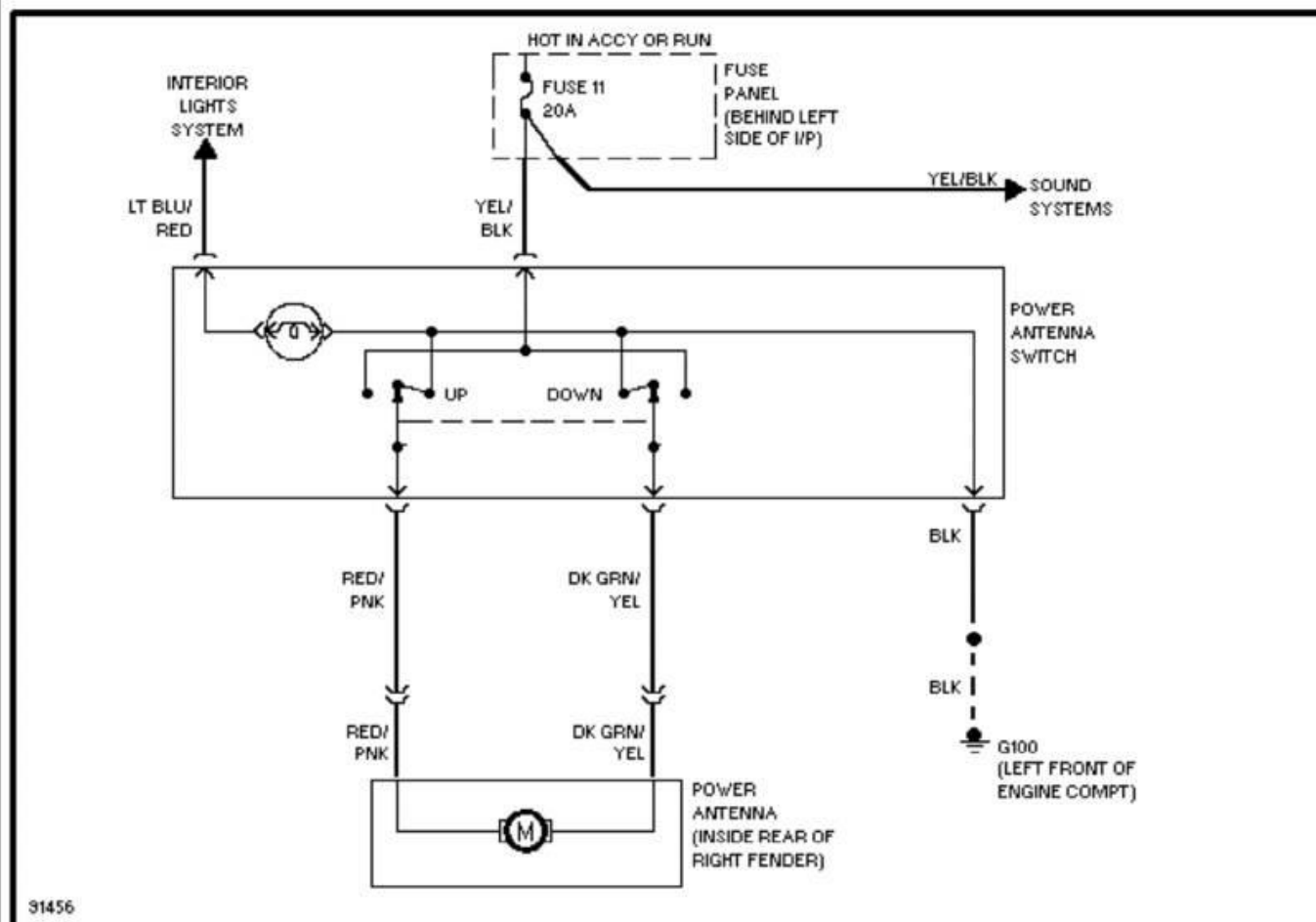

1990 System Wiring Diagrams
Ford - Taurus

PAVLIN

Fig. 8: Door Lock Circuit
1990 Ford Taurus LX

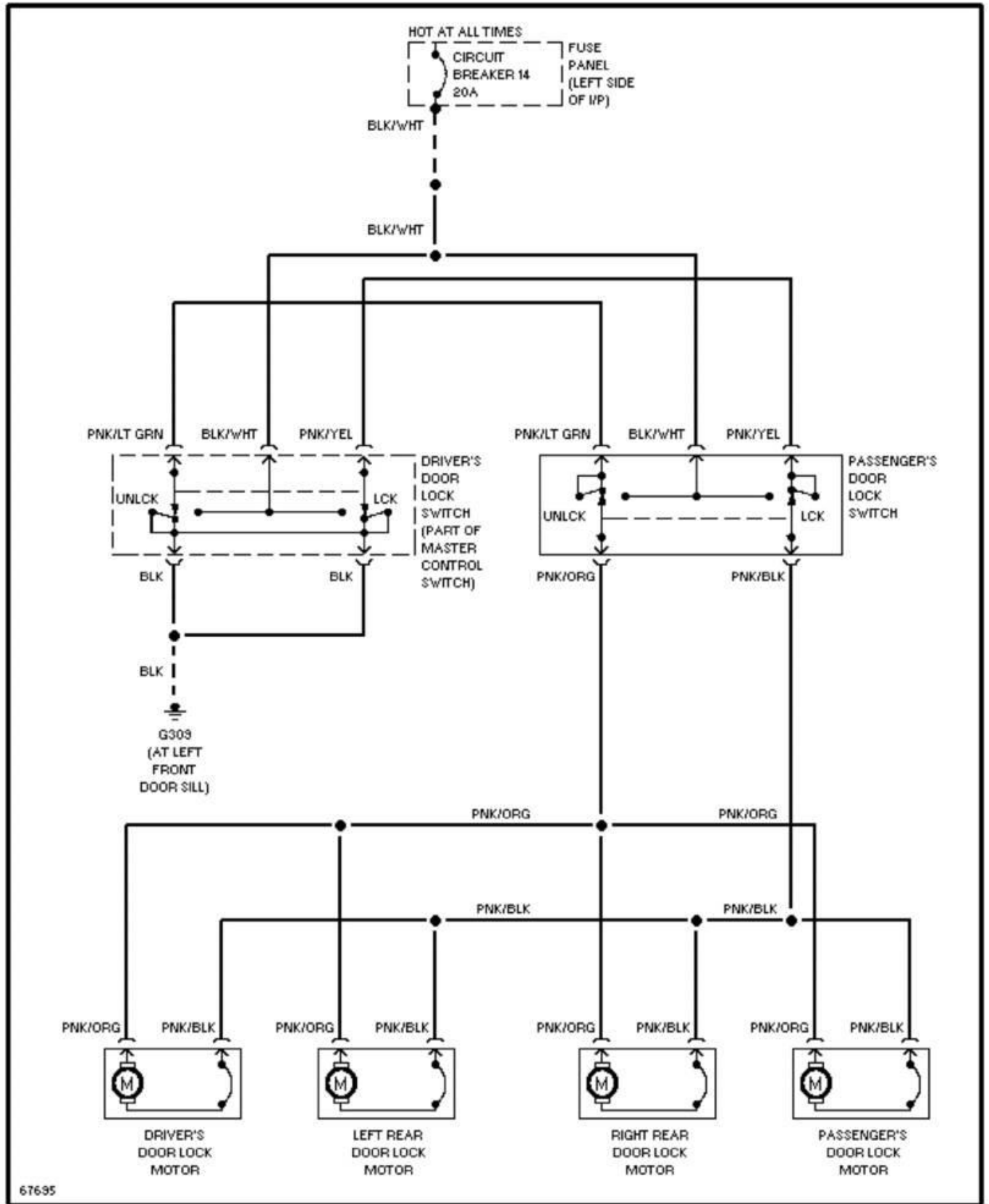

1990 System Wiring Diagrams Ford - Taurus

PAVLIN

Fig. 9: Keyless Entry Circuit
1990 Ford Taurus LX

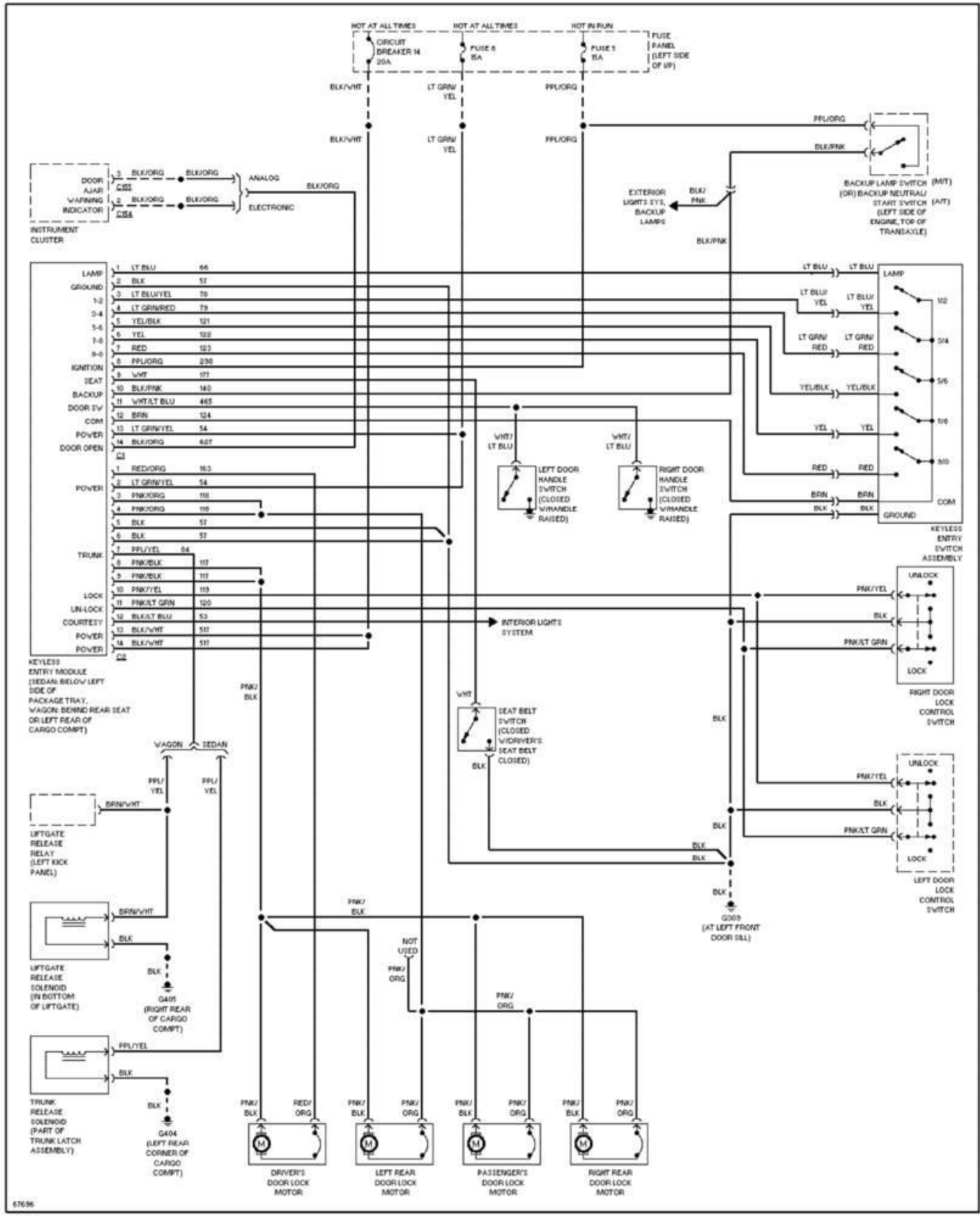

67636

1990 System Wiring Diagrams
Ford - Taurus

PAVLIN

Fig. 10: Power Mirror Circuit
1990 Ford Taurus LX

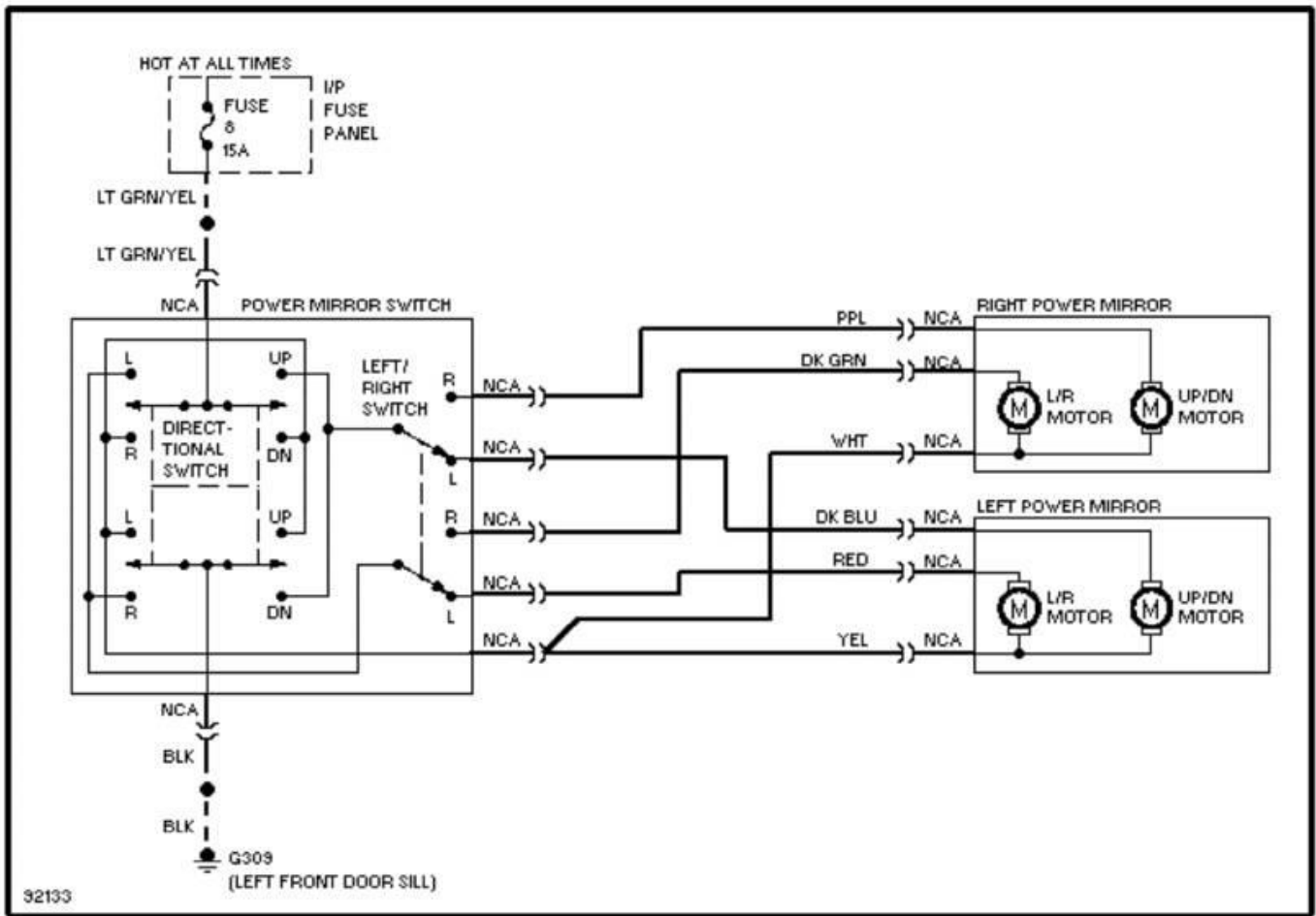

1990 System Wiring Diagrams
Ford - Taurus

PAVLIN

Fig. 11: Lumbar Circuit
1990 Ford Taurus LX

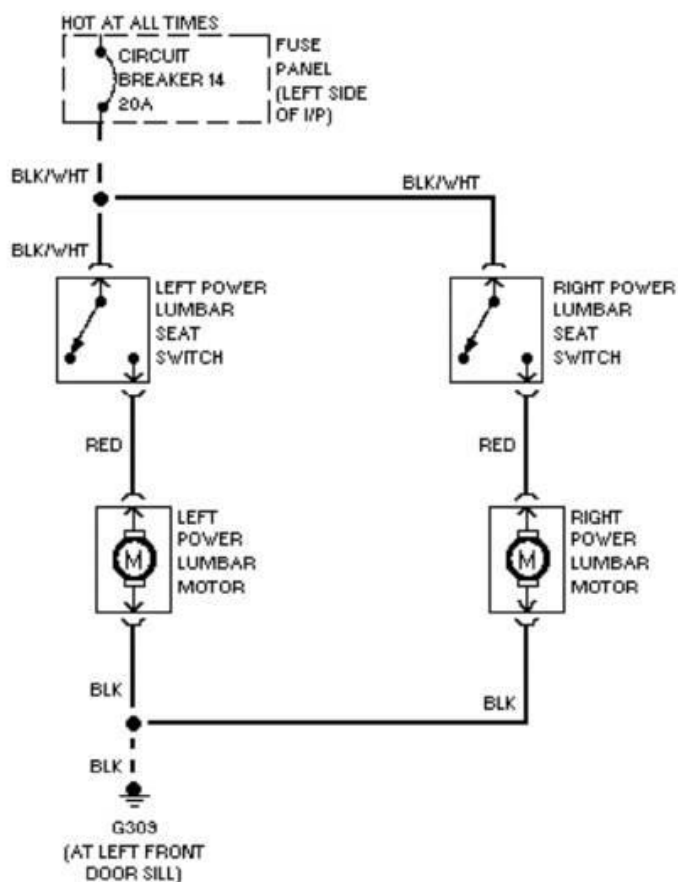

91736

1990 System Wiring Diagrams
Ford - Taurus

PAVLIN

Fig. 12: Power Seat Circuit
1990 Ford Taurus LX

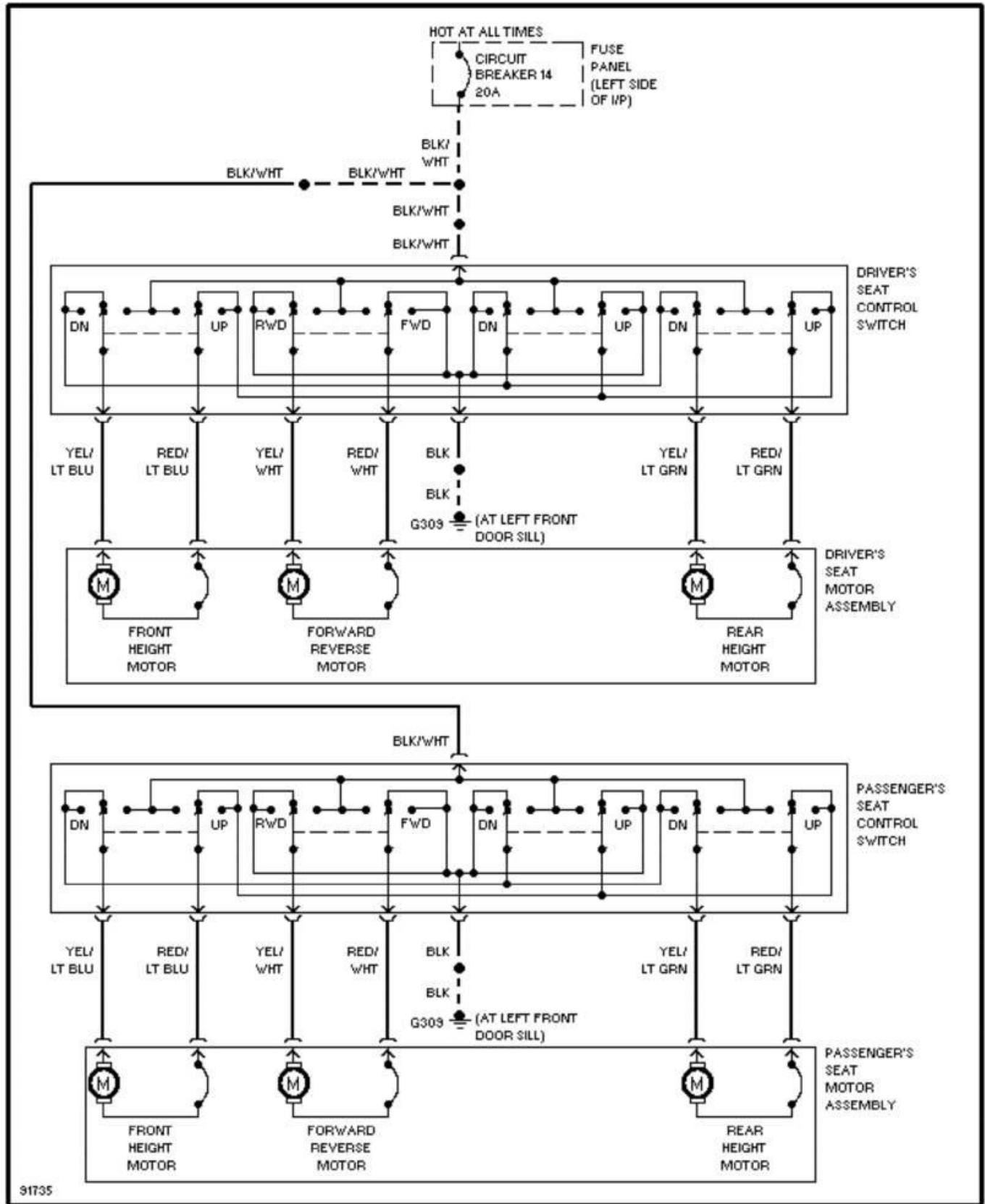

31735

1990 System Wiring Diagrams Ford - Taurus

PAVLIN

Fig. 13: Power Window Circuit
1990 Ford Taurus LX

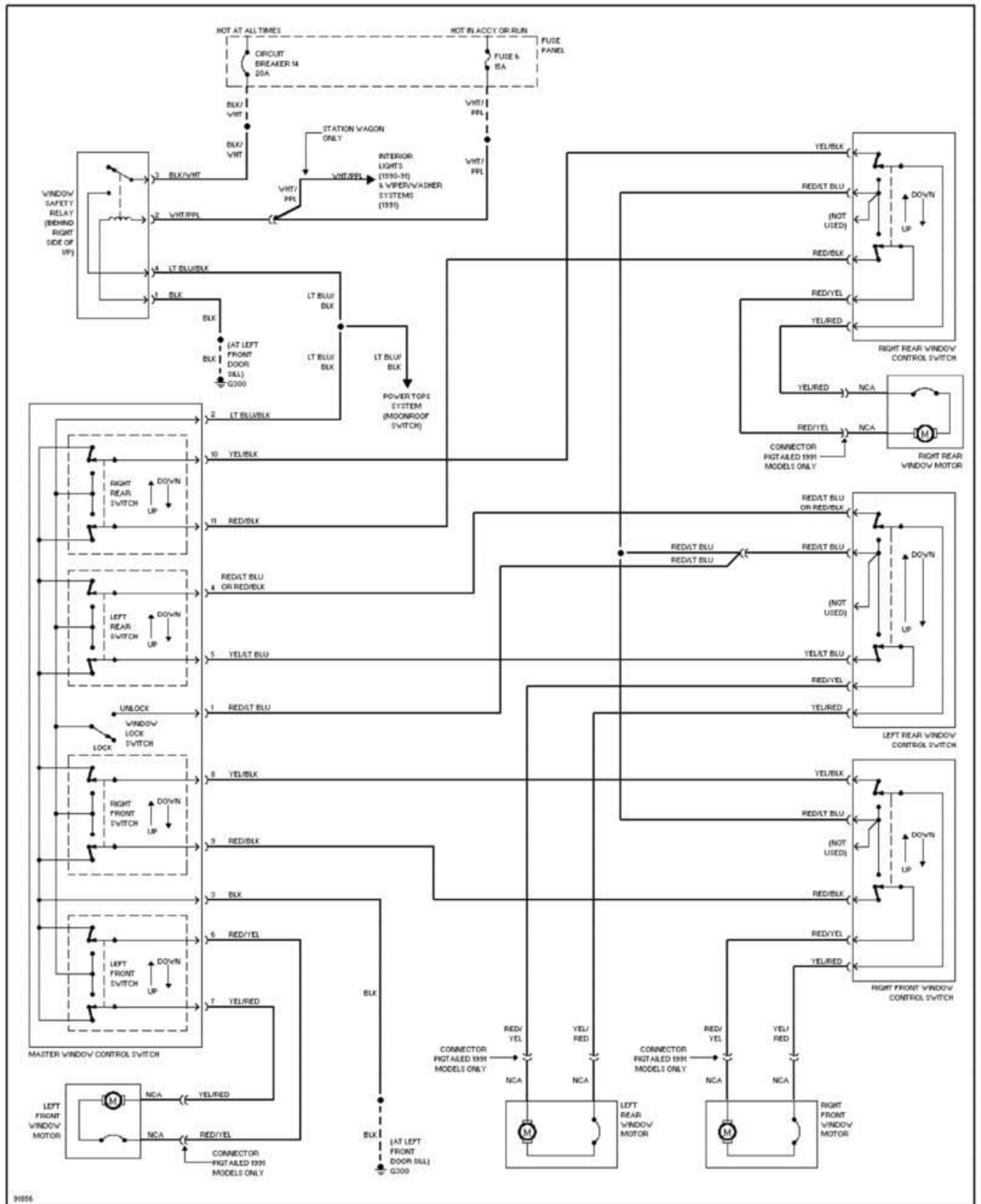

91856

1990 System Wiring Diagrams
Ford - Taurus

PAVLIN

Fig. 14: Radio Circuits
1990 Ford Taurus LX

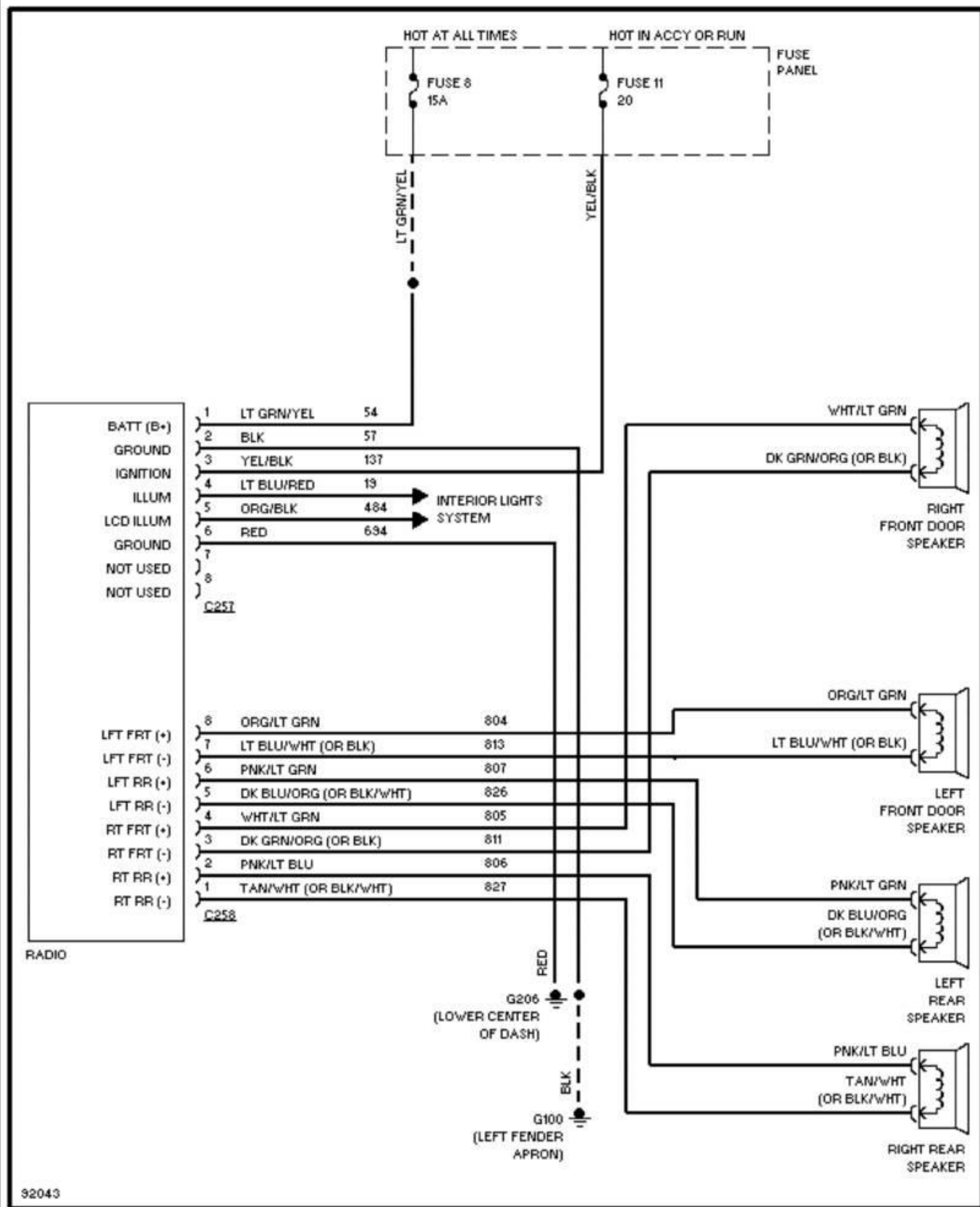

92043

1990 System Wiring Diagrams Ford - Taurus

PAVLIN

Fig. 15: Radio Circuits, JBL System
1990 Ford Taurus LX

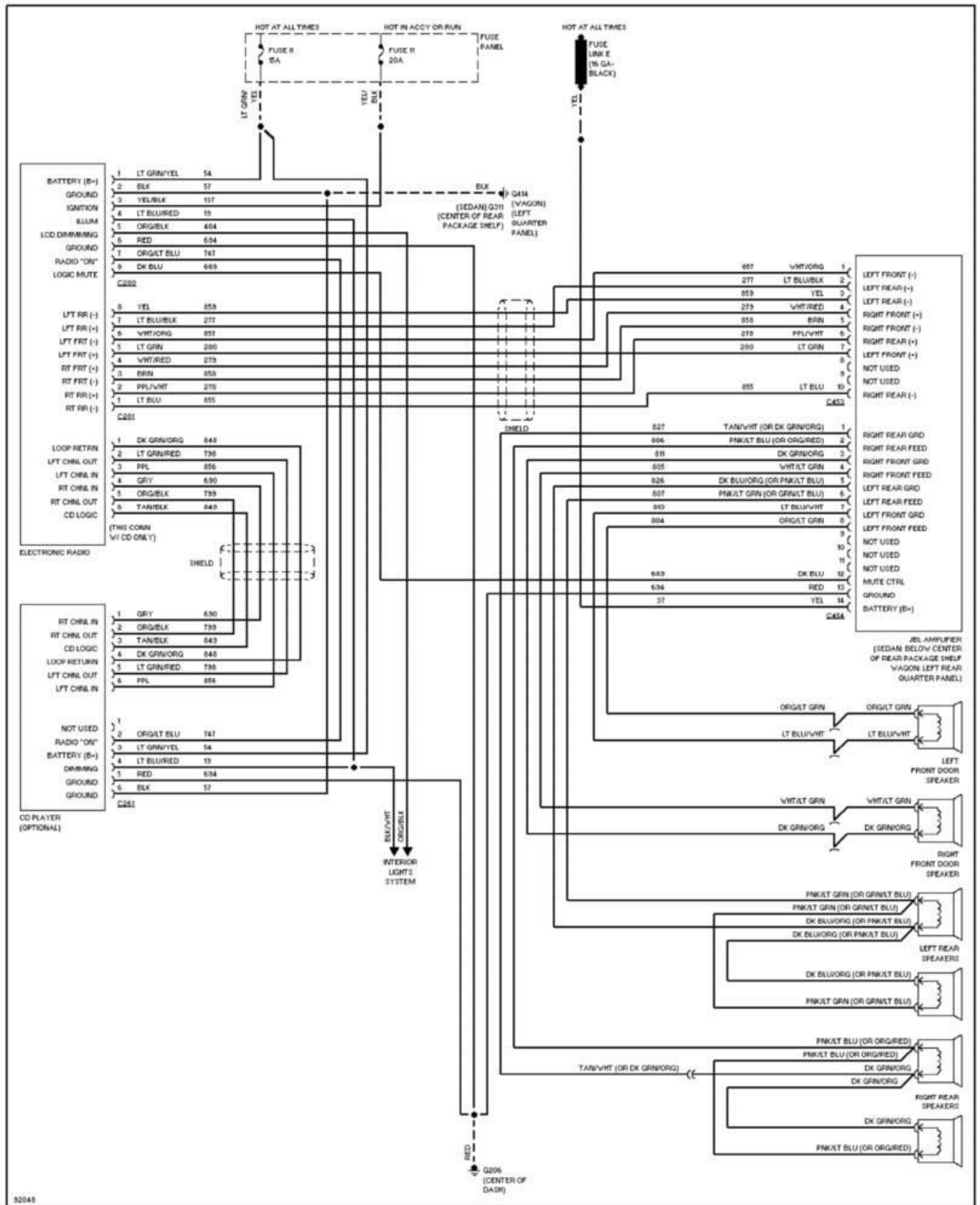

1990 System Wiring Diagrams
Ford - Taurus

PAVLIN

Fig. 17: 2.5L, Charging Circuit
1990 Ford Taurus LX

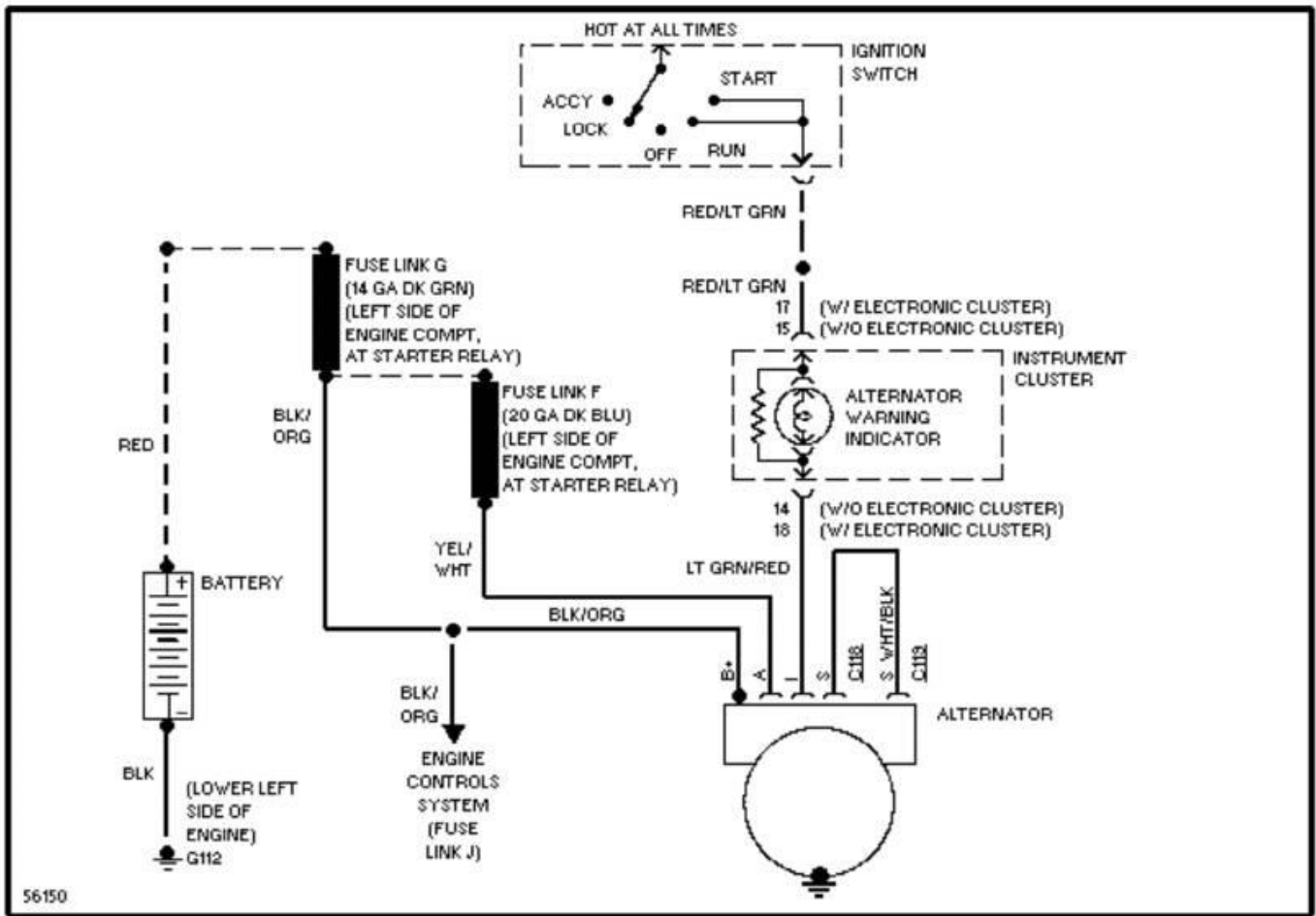

56150

1990 System Wiring Diagrams
Ford - Taurus

PAVLIN

Fig. 18: Starting Circuit
1990 Ford Taurus LX

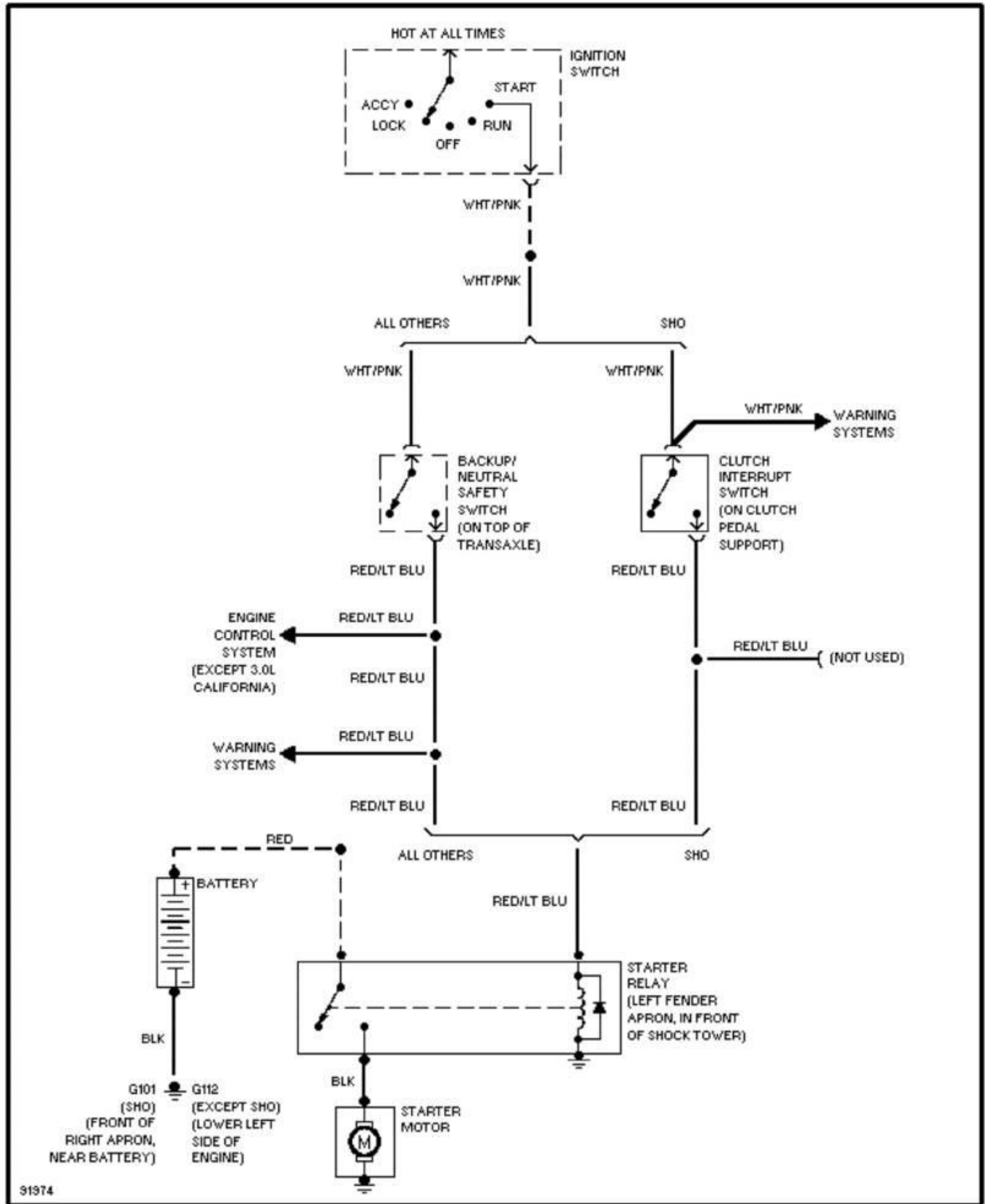

1990 System Wiring Diagrams
Ford - Taurus

PAVLIN

Fig. 19: 3.0L SHO, Charging Circuit
1990 Ford Taurus LX

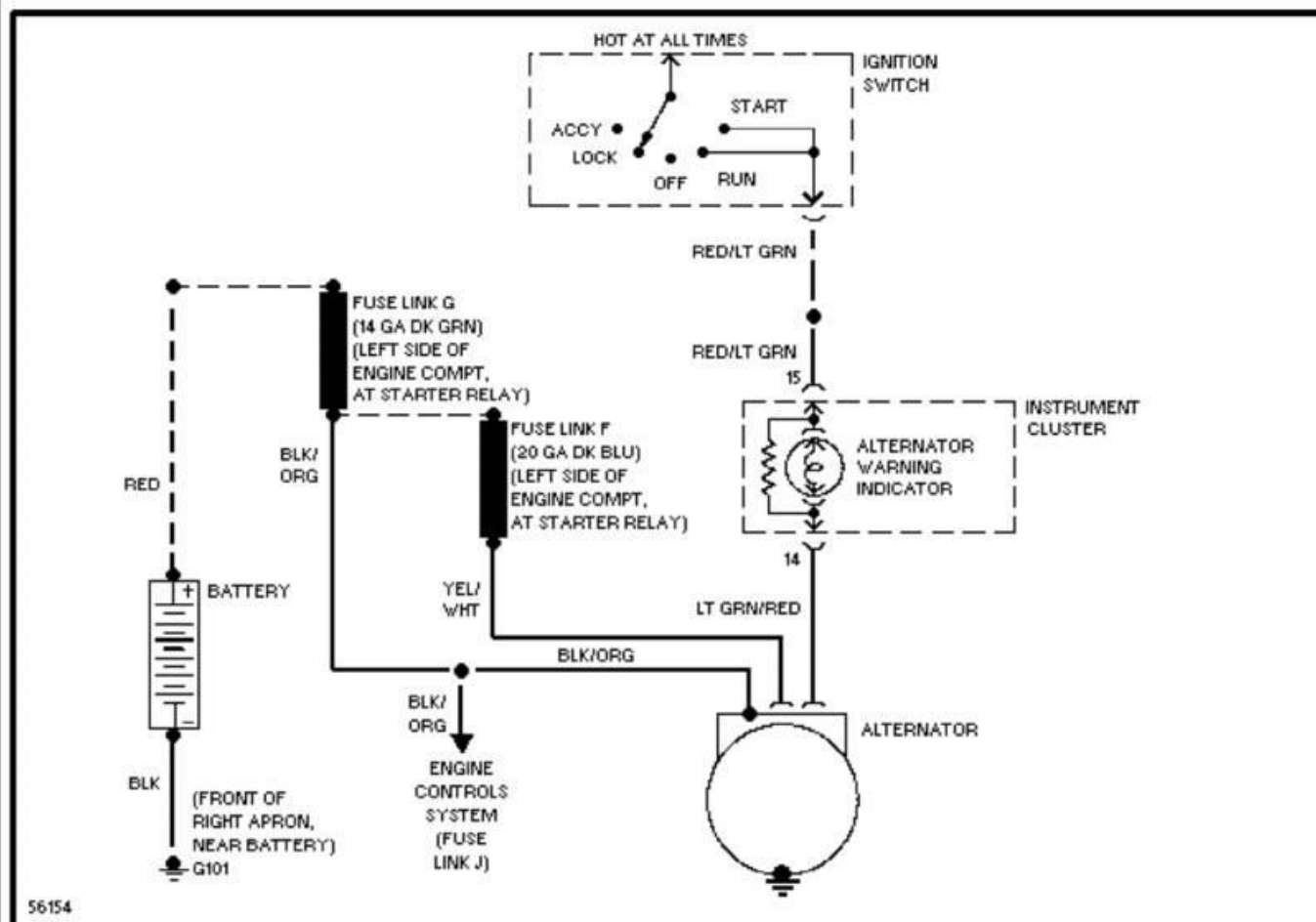

1990 System Wiring Diagrams
Ford - Taurus

PAVLIN

Fig. 20: 3.0L, Charging Circuit, Police Option
1990 Ford Taurus LX

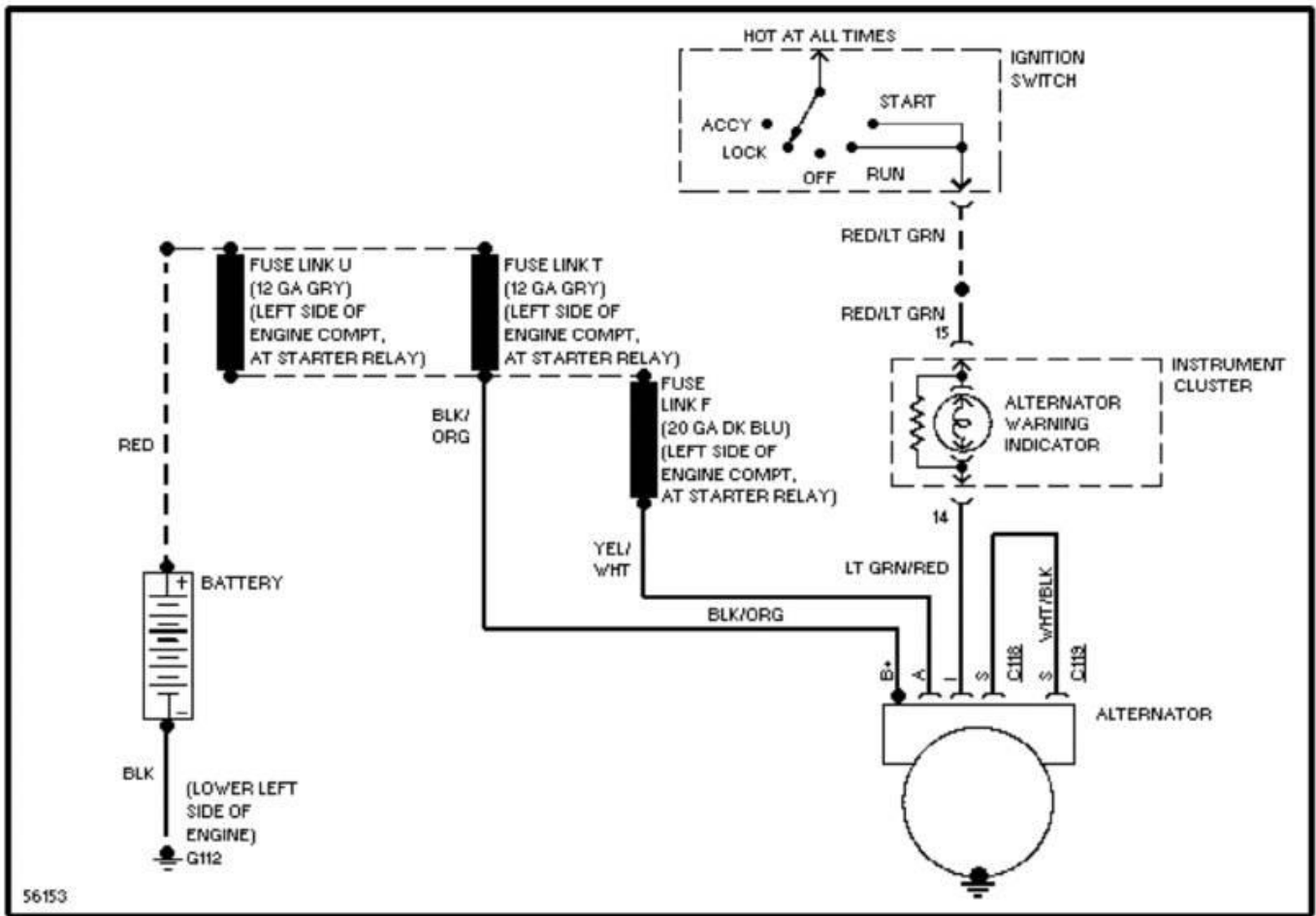

1990 System Wiring Diagrams
Ford - Taurus

PAVLIN

Fig. 21: 3.0L, Charging Circuit, W/ Heated Windshield
1990 Ford Taurus LX

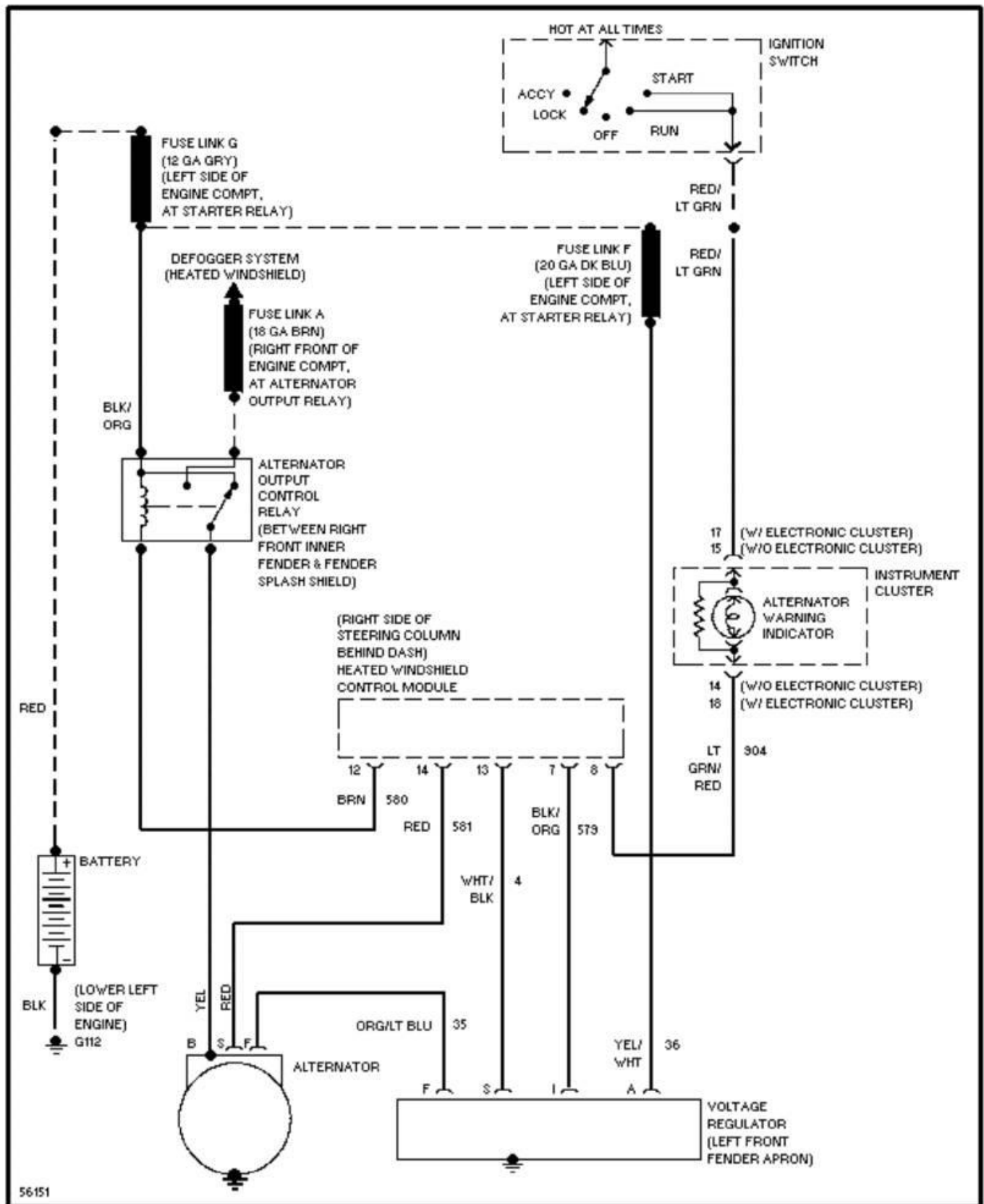

56151

1990 System Wiring Diagrams
Ford - Taurus

PAVLIN

Fig. 22: 3.0L, Charging Circuit, W/O Heated Windshield
1990 Ford Taurus LX

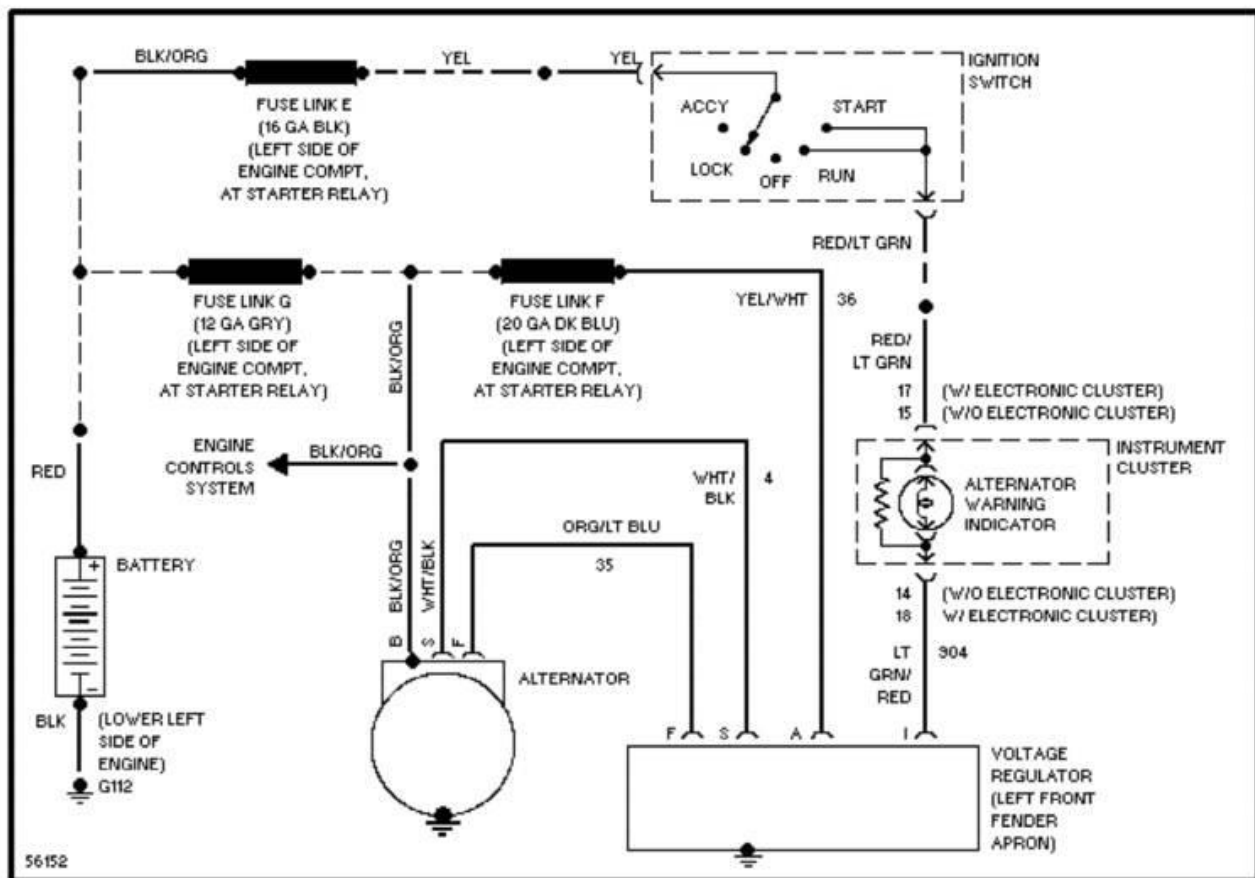

1990 System Wiring Diagrams
Ford - Taurus

PAVLIN

Fig. 23: Starting Circuit
1990 Ford Taurus LX

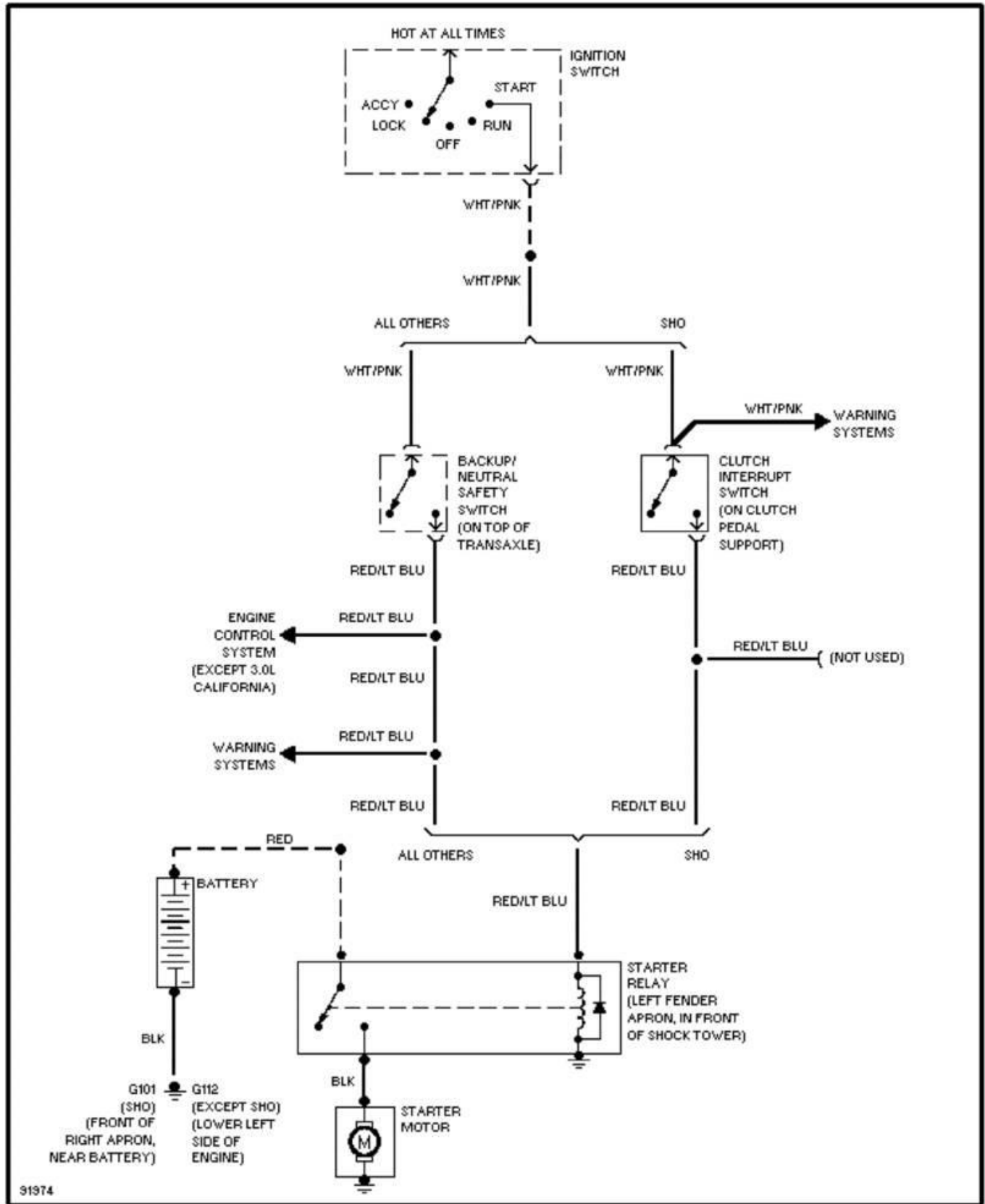

1990 System Wiring Diagrams
Ford - Taurus

PAVLIN

Fig. 24: 3.8L, Charging Circuit, Police Option
1990 Ford Taurus LX

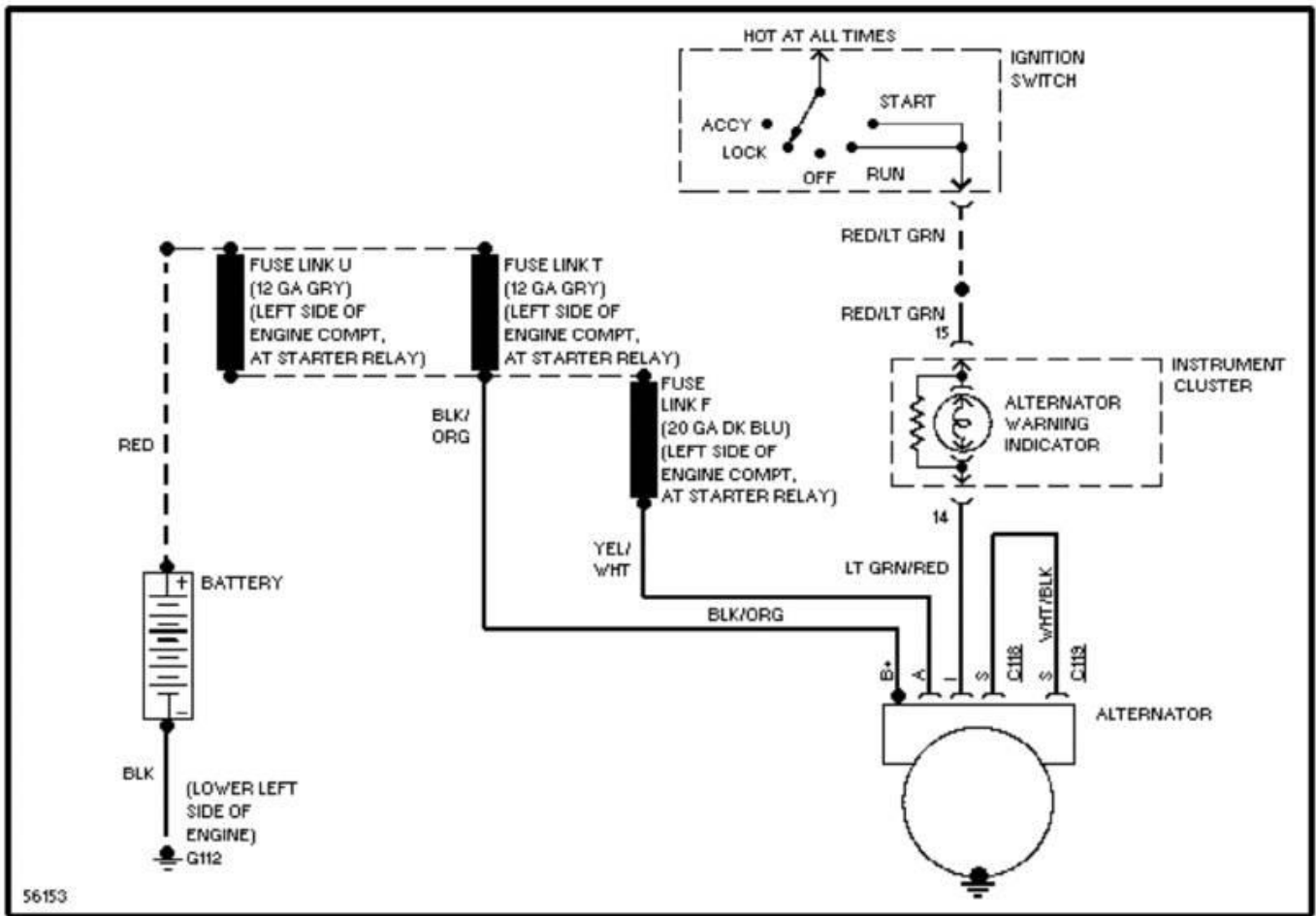

1990 System Wiring Diagrams
Ford - Taurus

PAVLIN

Fig. 25: 3.8L, Charging Circuit, W/ Heated Windshield
1990 Ford Taurus LX

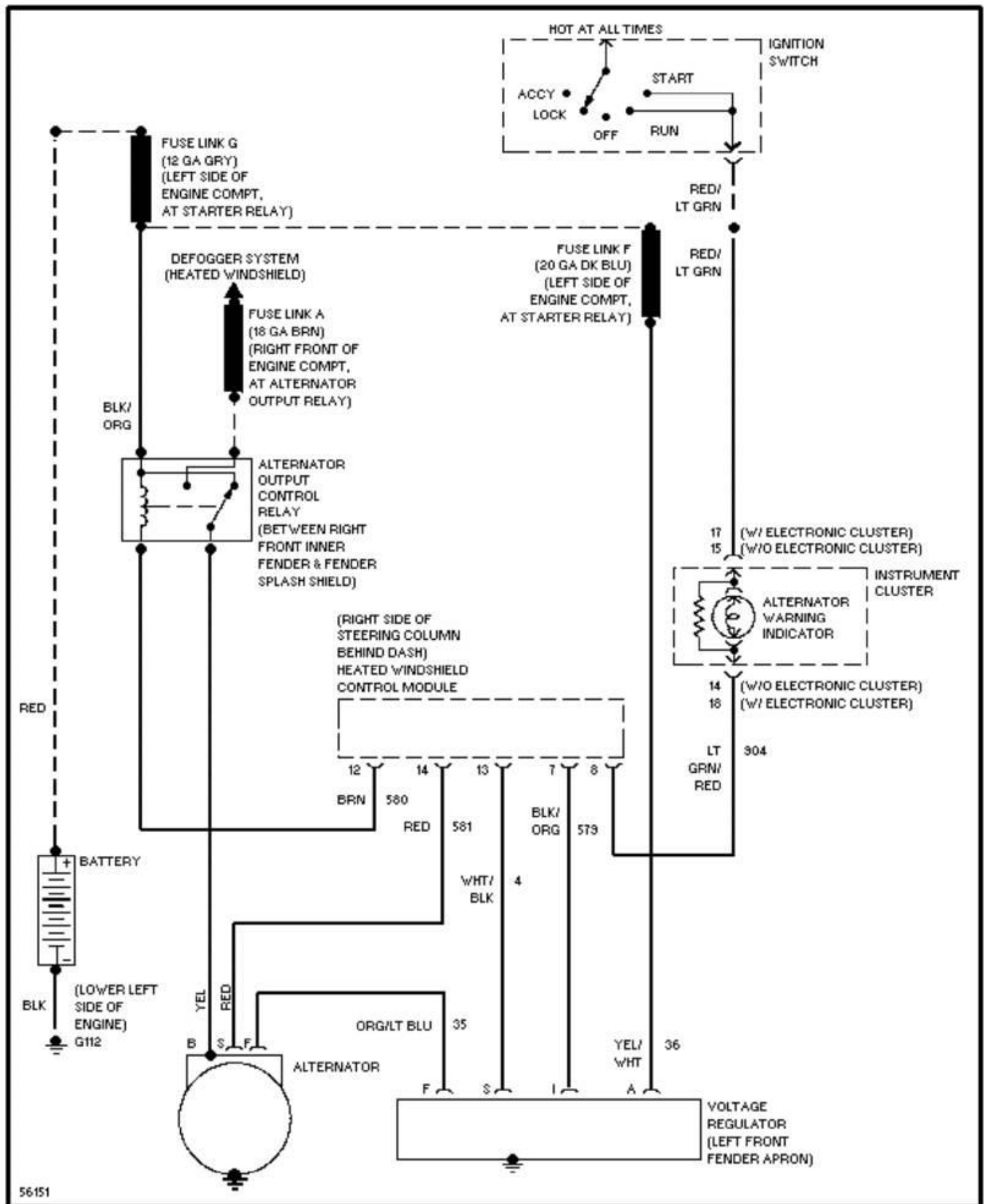

1990 System Wiring Diagrams
Ford - Taurus

PAVLIN

Fig. 26: 3.8L, Charging Circuit, W/O Heated Windshield
1990 Ford Taurus LX

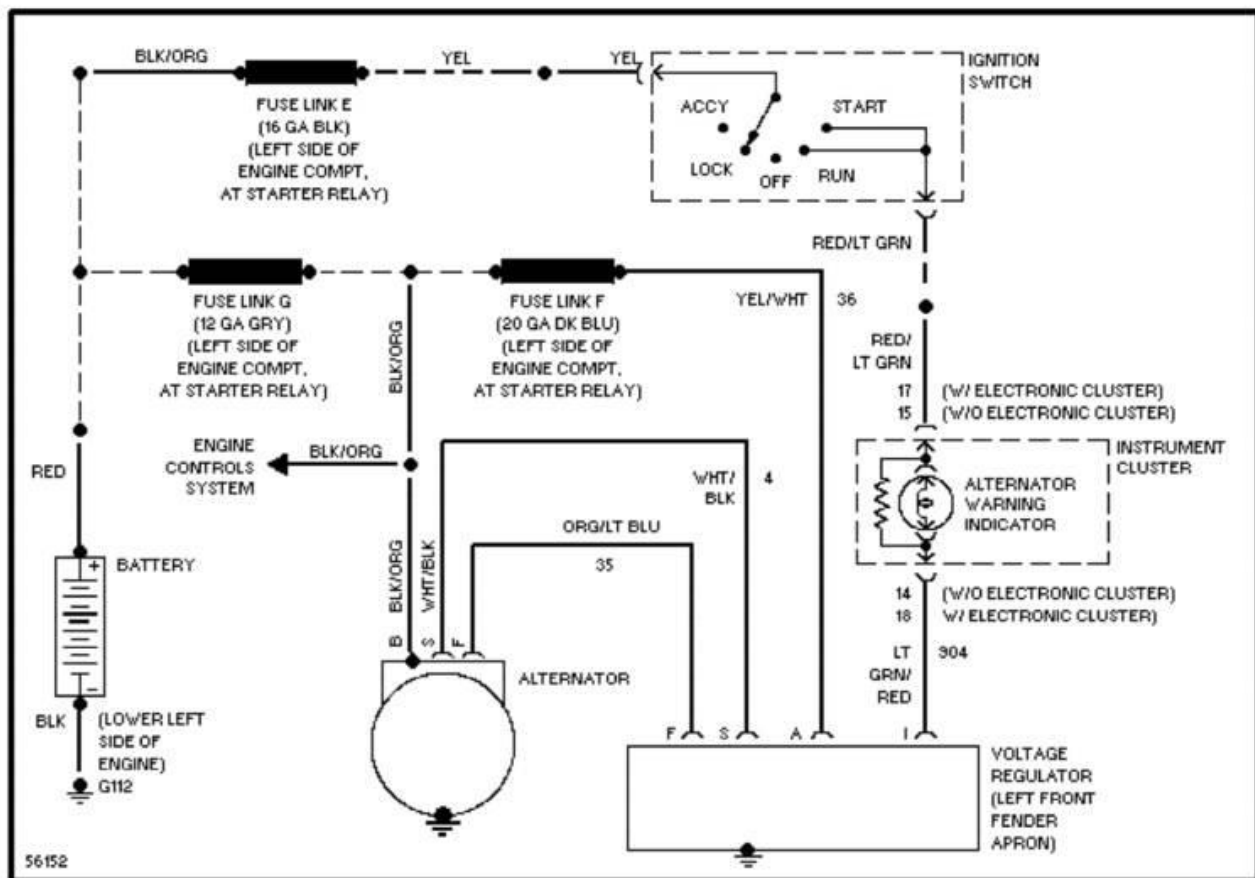

1990 System Wiring Diagrams
Ford - Taurus

PAVLIN

Fig. 27: Starting Circuit
1990 Ford Taurus LX

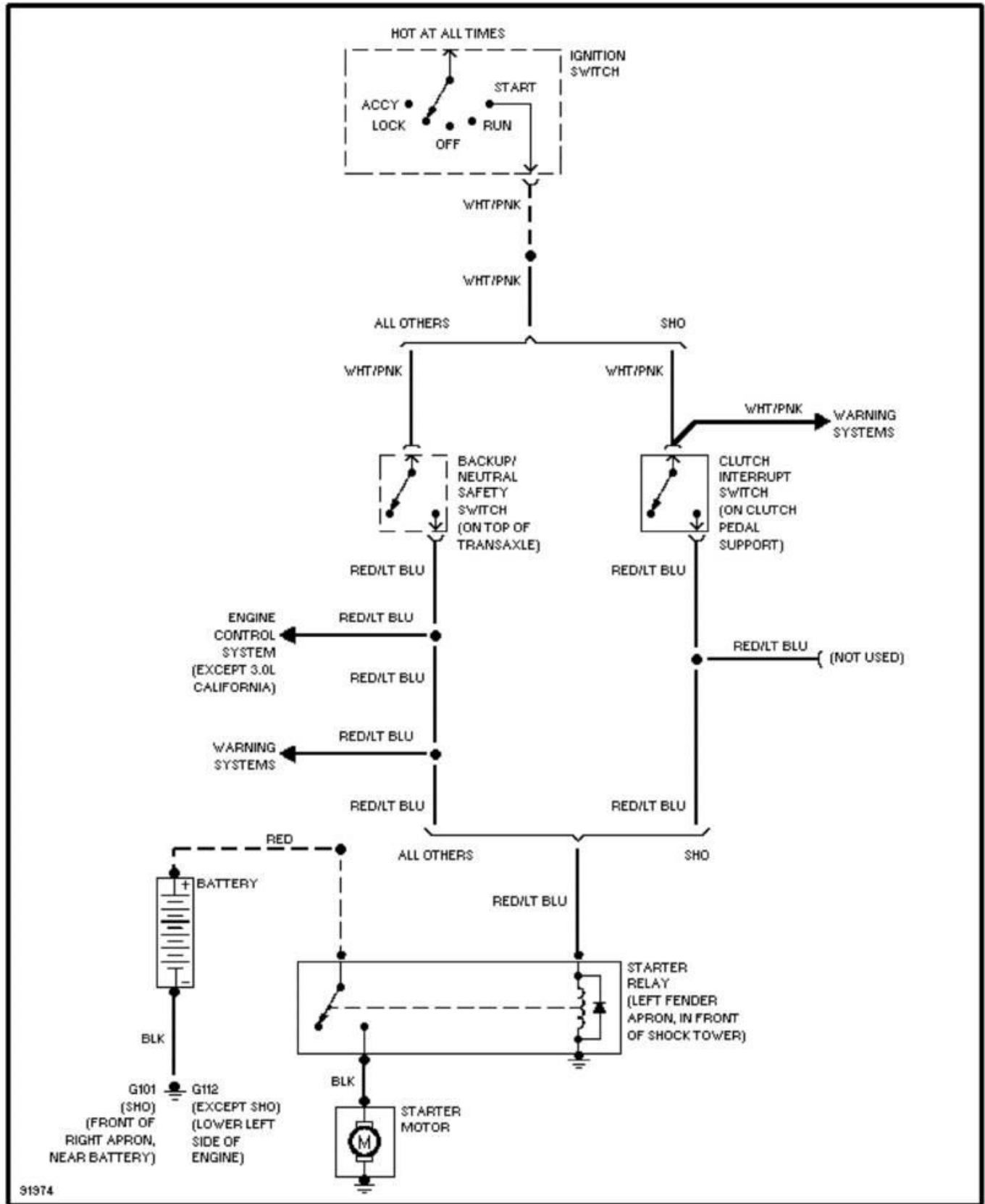

1990 System Wiring Diagrams
Ford - Taurus

PAVLIN

Fig. 28: Tailgate Release Circuit
1990 Ford Taurus LX

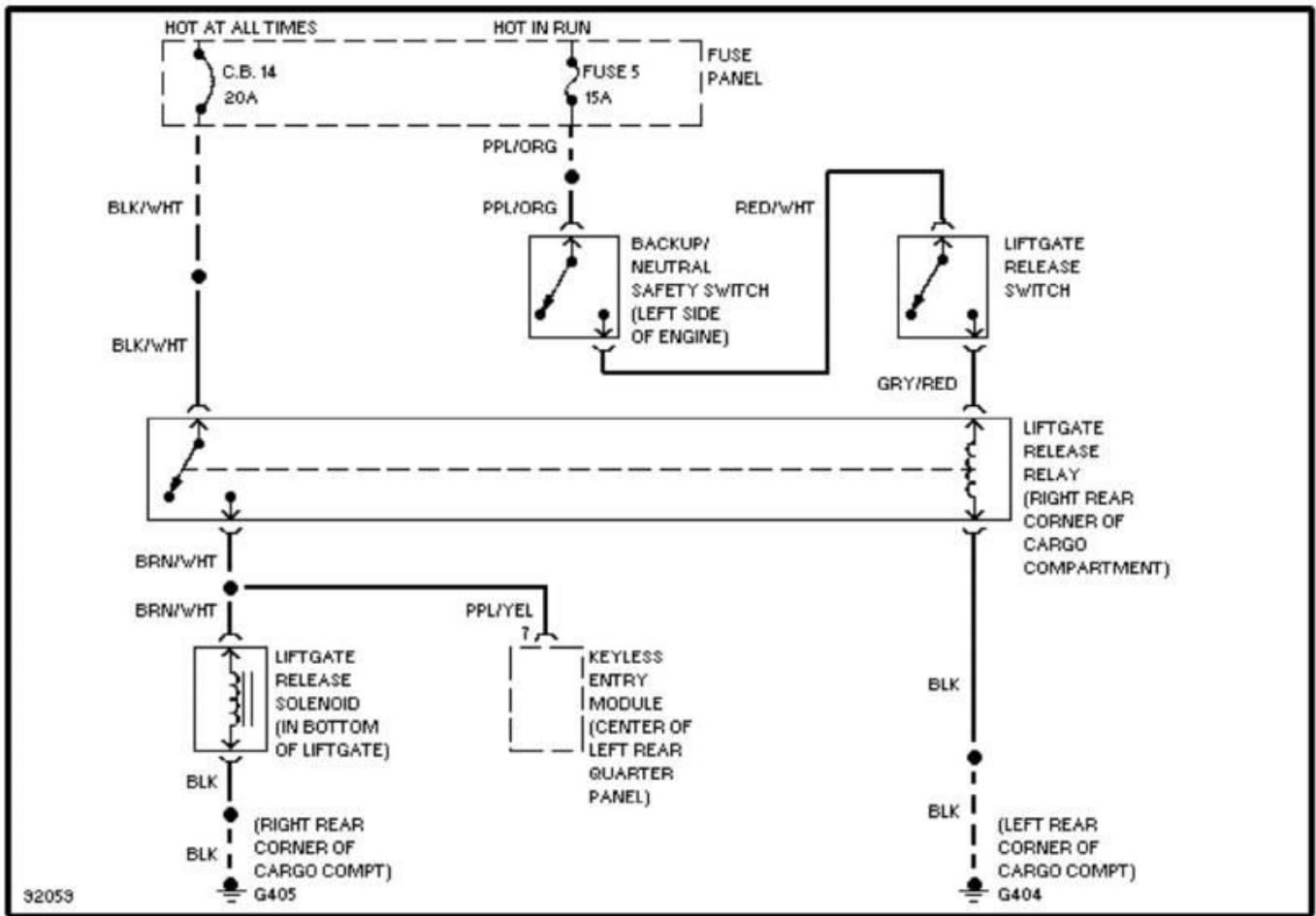

92059

1990 System Wiring Diagrams
Ford - Taurus

PAVLIN

Fig. 29: Trunk Release Circuit
1990 Ford Taurus LX

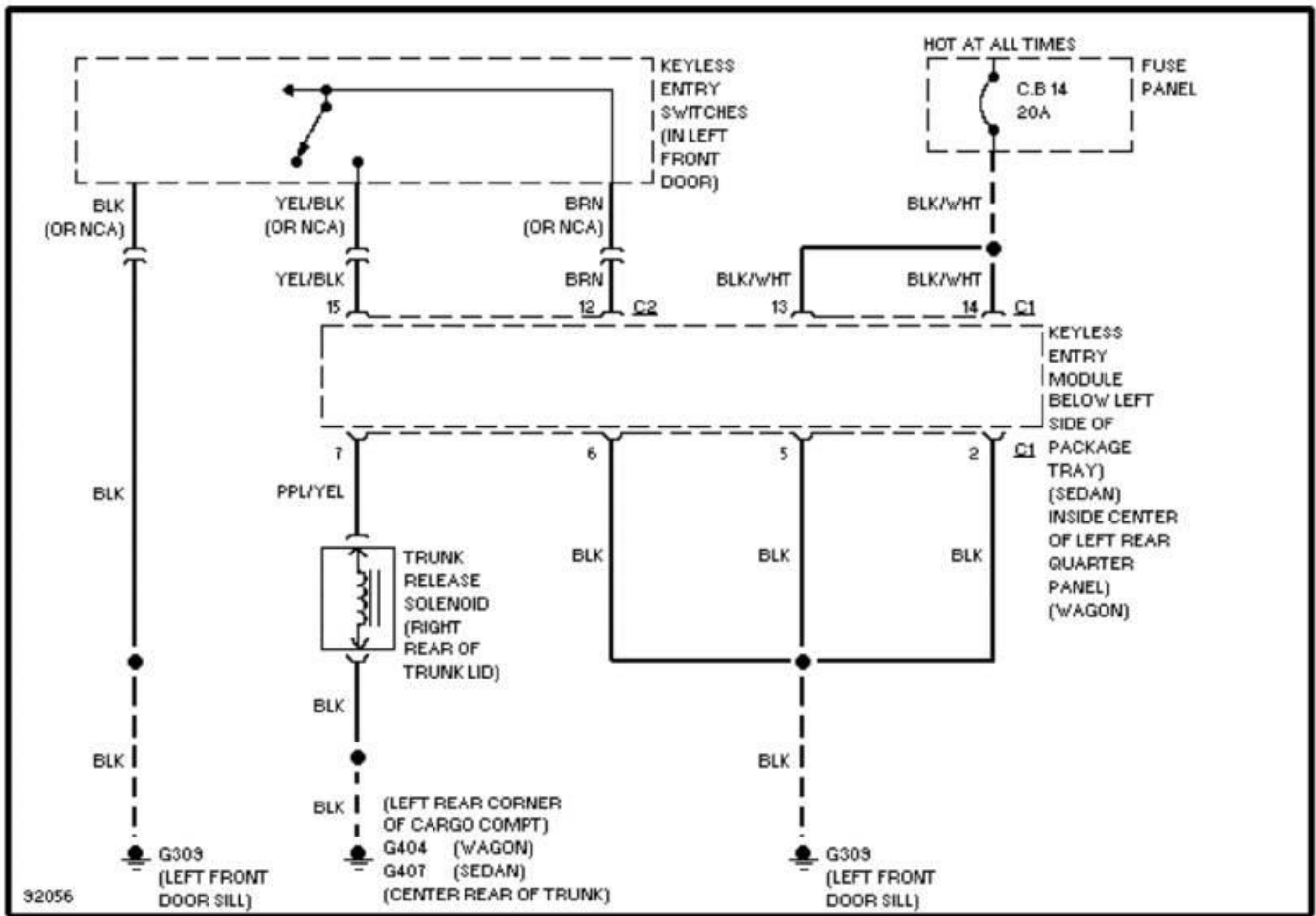

1990 System Wiring Diagrams Ford - Taurus

PAVLIN

Fig. 30: Interval Wiper/Washer Circuit
1990 Ford Taurus LX

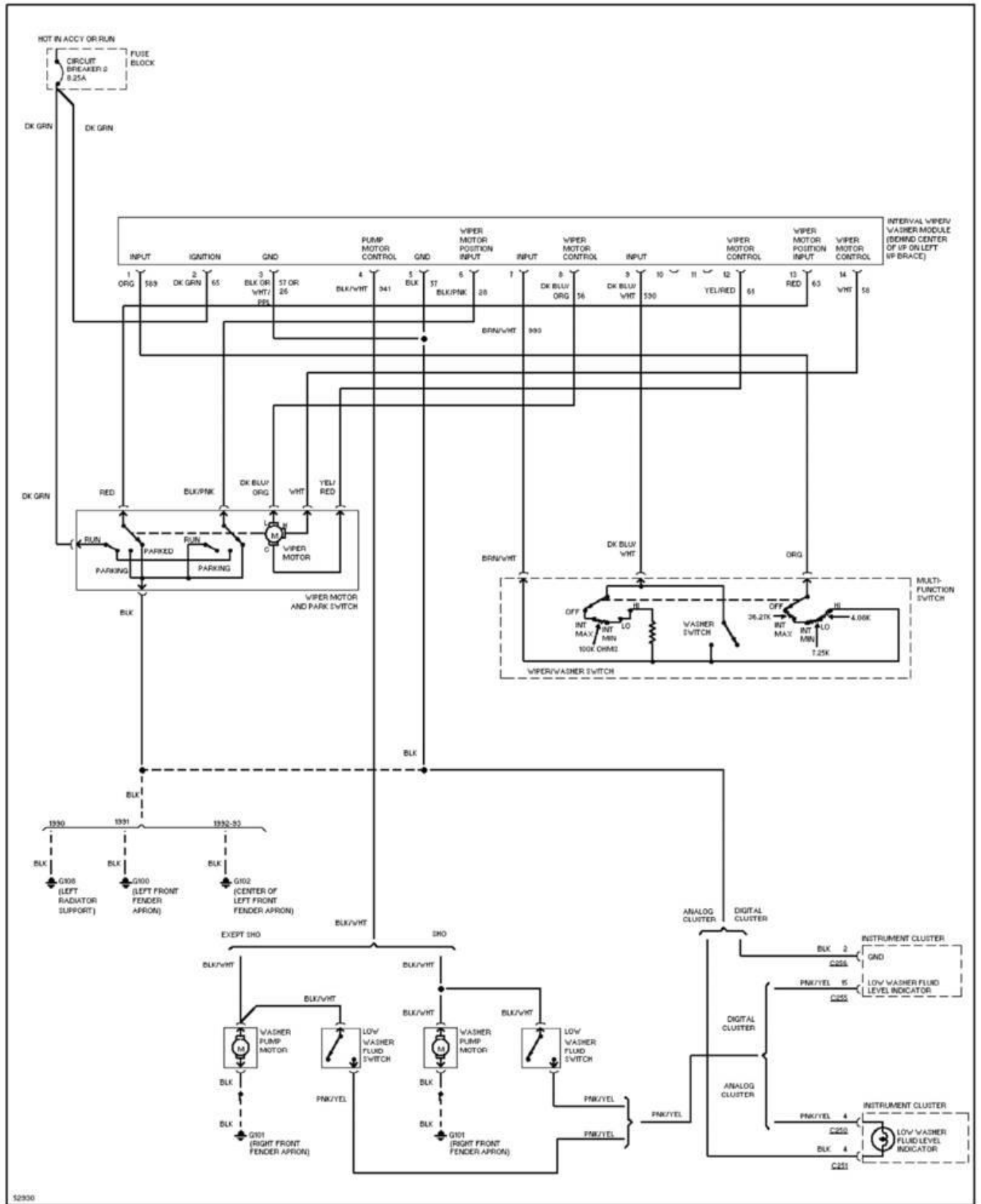

52930

1990 System Wiring Diagrams
Ford - Taurus

PAVLIN

Fig. 31: Rear Wiper/Washer Circuit
1990 Ford Taurus LX

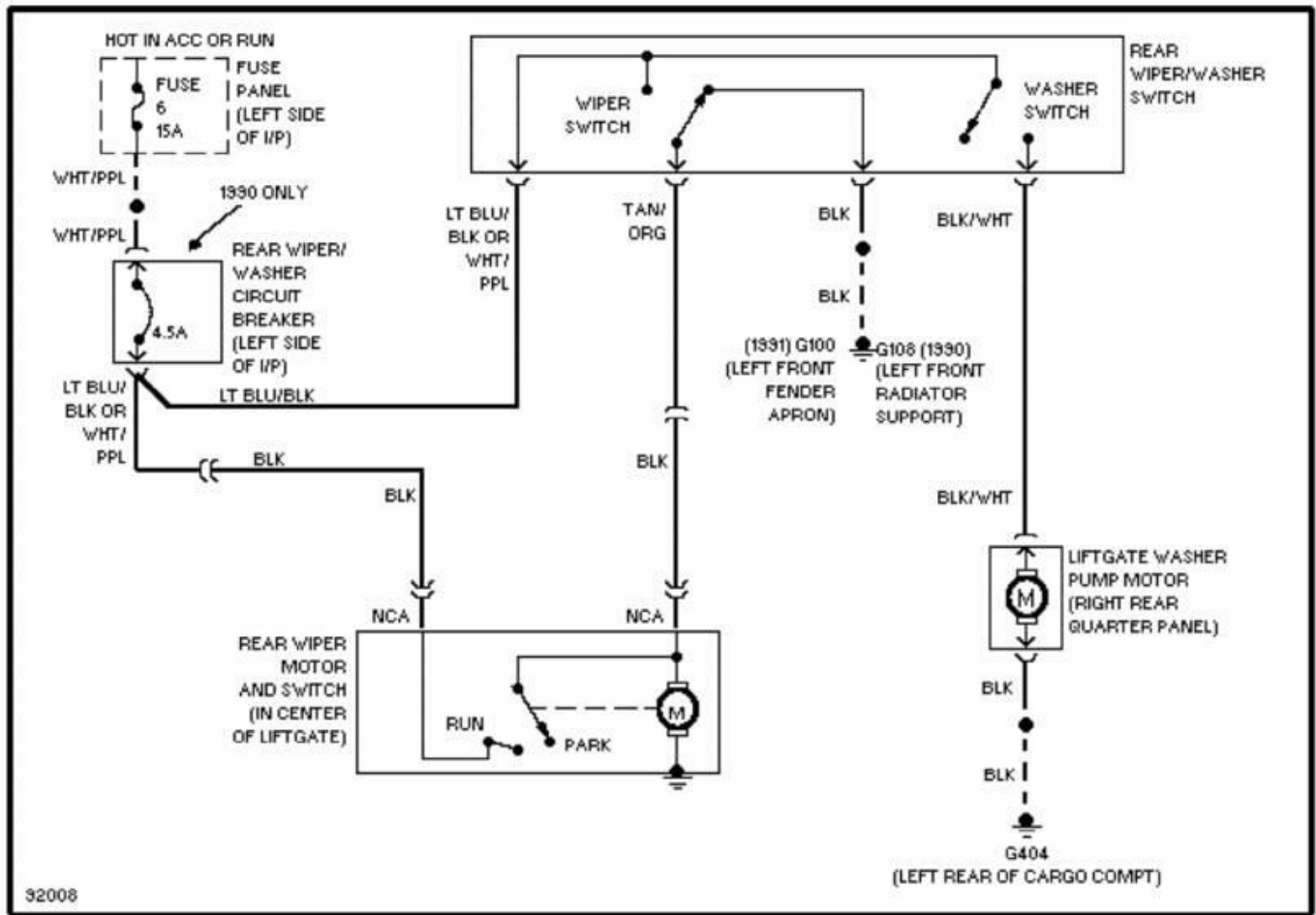

WIRING DIAGRAMS

1990 Wiring Diagrams Ford Motor Co.

PAVLIN

Fig. 1: Headlights & Washer/Wiper (Grid 1-3)
1990 Ford Taurus LX

COMPONENT LOCATOR:

A/C CLUTCH CYCLING PRES SW	C 37
A/C CLUTCH CYCLING PRES SW (3.0L SHO)	D 37
A/C/HEATER FUNCTION SW	B-D 36
ABS CTRL MOD	A 32-35
AIR BAG BACK-UP POWER SUPPLY	D 32
AIR BAG DIAG MOD	D-E 32
ALT OUTPUT CTRL RLY	D 44
ALTERNATORS	A-E 4-7
ANALOG/SHO INST CLSTR	A 48-51
ANTI-LOCK MOTOR RLY	C 32
ANTI-LOCK POWER RLY	C 35
AUTOLAMP SYS	E 46-47
BACKUP LT SW (M/T)	D 57
BATTERIES	A-E 4-7
BLOWER MOTOR (W/ EATC)	A 39
CHD LIGHT ASSY	D 44
CLUTCH SW (3.0L SHO M/T)	B 21
COURTESY LTS	A-C 44-47
CRUISE CTRL SERVO	E 28
DIAG WARN MOD	A-B 43
DIS MODULE (3.0L SHO)	C 56
DOOR AJAR SWS	C 48
DUAL BRAKE WARNING SW	A-B 36
EATC CTRL MOD (2.5L)	B-E 8
ELECT ENG CTRL (EEC) (3.0L SHO)	A 18-19
ELECT ENG CTRL (EEC) (3.0L)	B-E 12
ELECT ENG CTRL (EEC) (3.8L)	A 24-27
ELECT INST CLSTR	E 49-51
ENGINE COMPT LT	E 2
ENGINE SENSORS (3.0L SHO)	A 20-21
ENGINE SENSORS (3.8L)	E 22-23
FOG LT RLY	D 3
FOG LT SW (3.0L SHO)	E 43
FOG LTS IN-LINE FUSE	D 3
FUS LINKS	A-E 4-7
FUSE BLOCK	C-D 29-30
HEATED WINDSHIELD	E 39
HEATED WINDSHIELD CTRL MOD	D 38
HEATED WINDSHIELD FUS LINK	D 38
HEATER FUNCTION SEL SW	B 39
HEGO SENS (2.5L)	D 10
HEGO SENS (3.0L)	D 14
HEGO SENSORS (3.0L SHO)	E 18
HEGO SENSORS (3.8L)	E 26
HORN RLY	D 41
IGNITION COIL (2.5L)	B 11
IGNITION COIL (3.0L)	B 15
IGNITION COIL (3.8L)	B 24
IGNITION SW	A-C 28
IGNITION SW FUS LINKS	B 30
ILLUM ENTRY TIMER	B 56
INST PANEL DIMMING RHEOSTAT	D 47
INTEGRATED CTRL MOD (ICM) (2.5L)	A-B 11
INTEGRATED CTRL MOD (ICM) (3.0L SHO)	A 22-23
INTEGRATED CTRL MOD (ICM) (3.0L)	A-B 15
INTEGRATED CTRL MOD (ICM) (3.8L)	E 20-21
INTERVAL WIPER/WASHER MOD	E 40
KEYLESS ENTRY SYS	B-C 54-55
LIFTGATE RELEASE RLY	D 56
LOW OIL LEVEL RLY	B 51
MAIN LT SW	E 44
MASTER WINDOW CTRL SW	B-D 52
MOONROOF	B-C 57-58
MULTI-FUNCTION SW	A-D 40
NEUT/SAFETY/BACK-UP LT SW (A/T)	A-B 31
POLICE ACCY RLY	B 56
POWER ANTENNA	E 57
POWER DOOR LOCKS (W/ KEYLESS ENTRY)	A 52-55
POWER DOOR LOCKS (W/O KEYLESS ENTRY)	A 56-59
POWER MIRRORS	D-E 54-55
POWER SEATS	D-E 52-54
POWER WINDOW SAFETY RLY	A 52
REAR WINDOW DEFOG CTRL	E 43
REAR WIPER/WASHER SYS	E 56-57
SELF TEST OUTPUT (STO) CONN (2.5L)	C 10
SELF TEST OUTPUT (STO) CONN (3.0L SHO)	E 18-19
SELF TEST OUTPUT (STO) CONN (3.8L)	C 15
STARTER RLYS	A-E 4-7
STEERING WHEEL CTRL SW	D 43
STOP LT SW	C 42
TFIGN MOD (3.8L)	C-D 25
VARIABLE ASSIST POWER STEERING (VAPS) MOD	E 35
WARNING CHIME MOODS	E 36-38
WASHER FLUID LEVEL SW	B-C 3
WIPER MOTOR & PARK SW	A 3

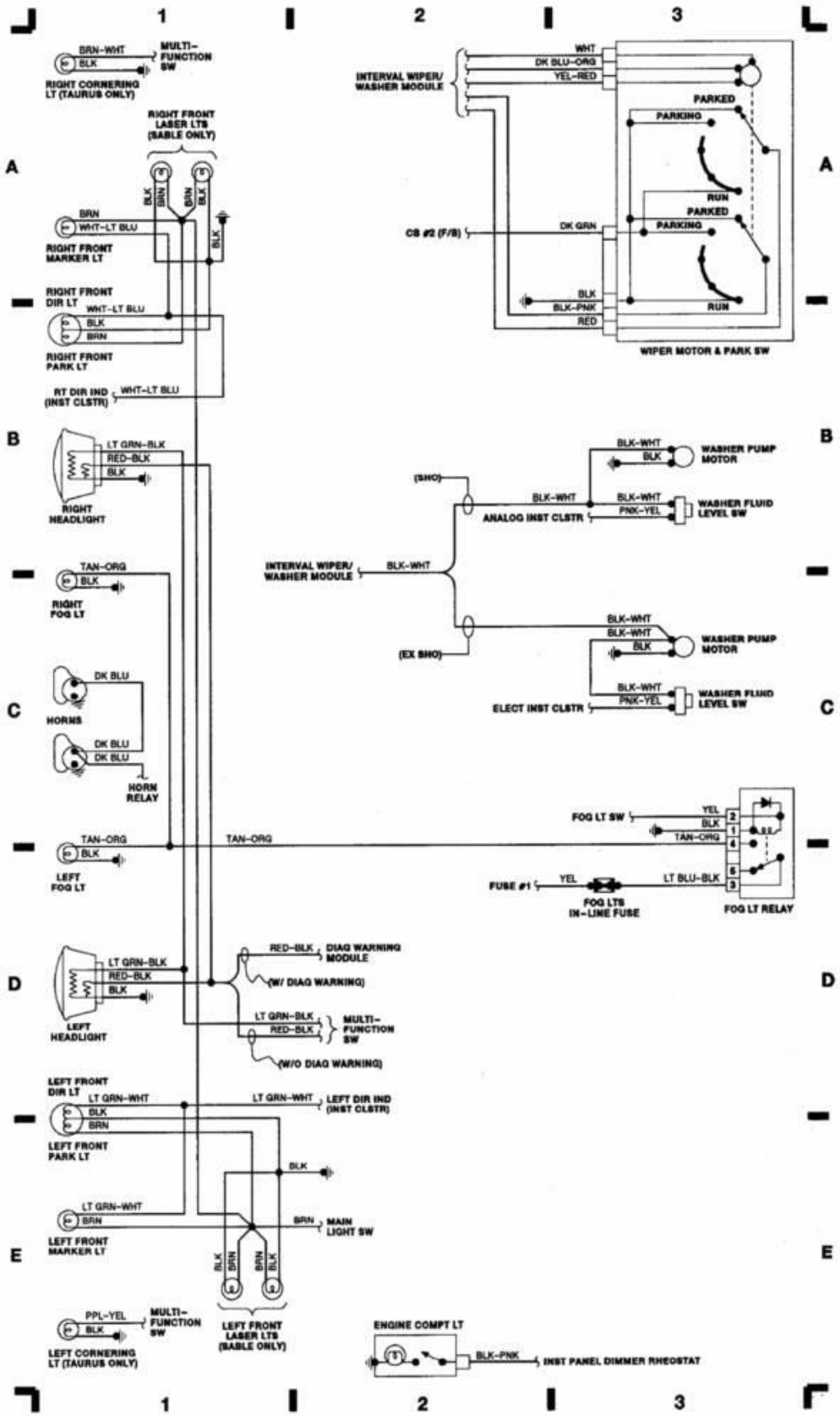

90A16360

WIRING DIAGRAMS

1990 Wiring Diagrams Ford Motor Co.

PAVLIN

Fig. 2: Engine Compartment (Grid 4-7)
1990 Ford Taurus LX

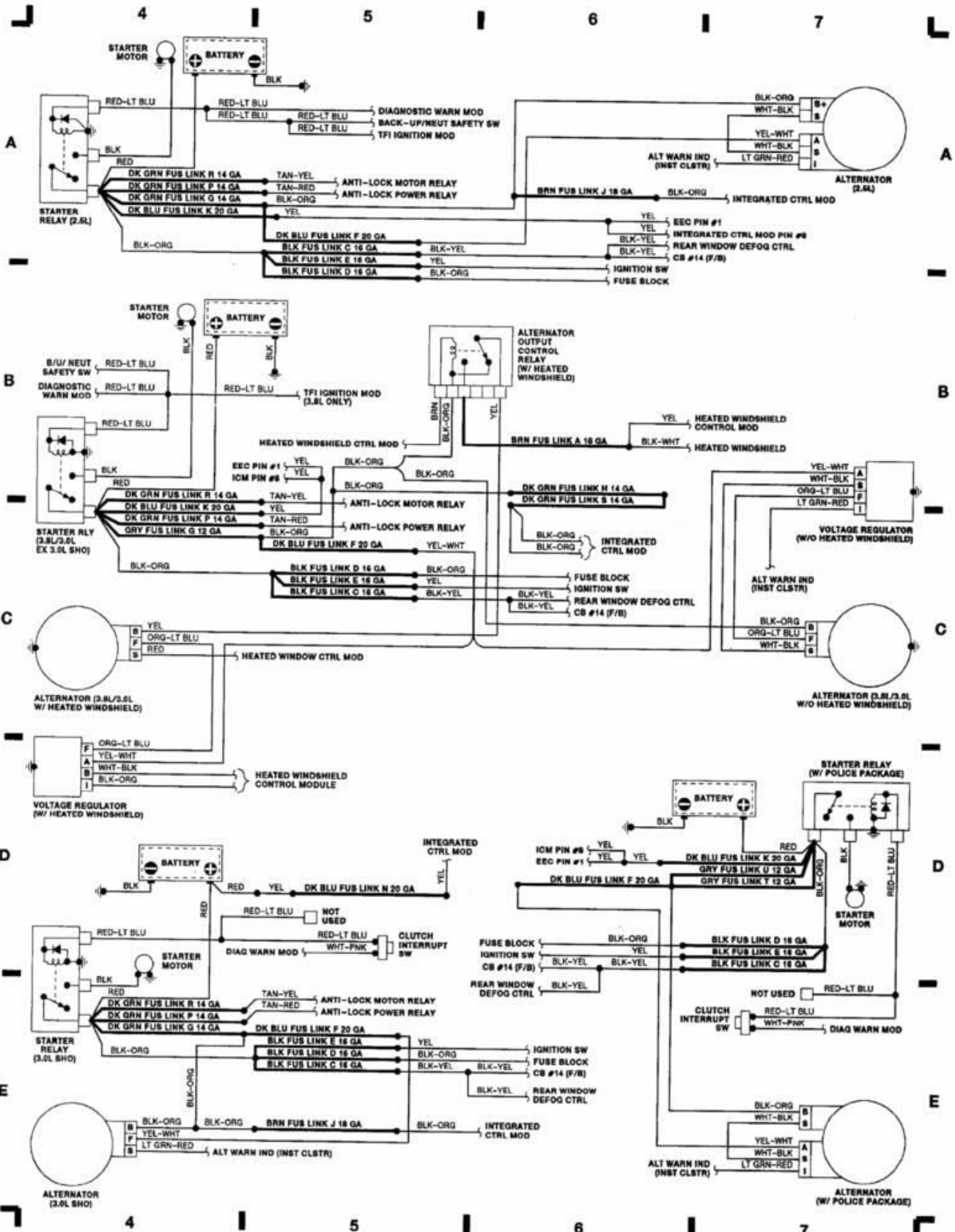

90B16361

WIRING DIAGRAMS

1990 Wiring Diagrams Ford Motor Co.

PAVLIN

Fig. 4: Electronic Engine Control (3.0L EFI) (Grid 12-15)
1990 Ford Taurus LX

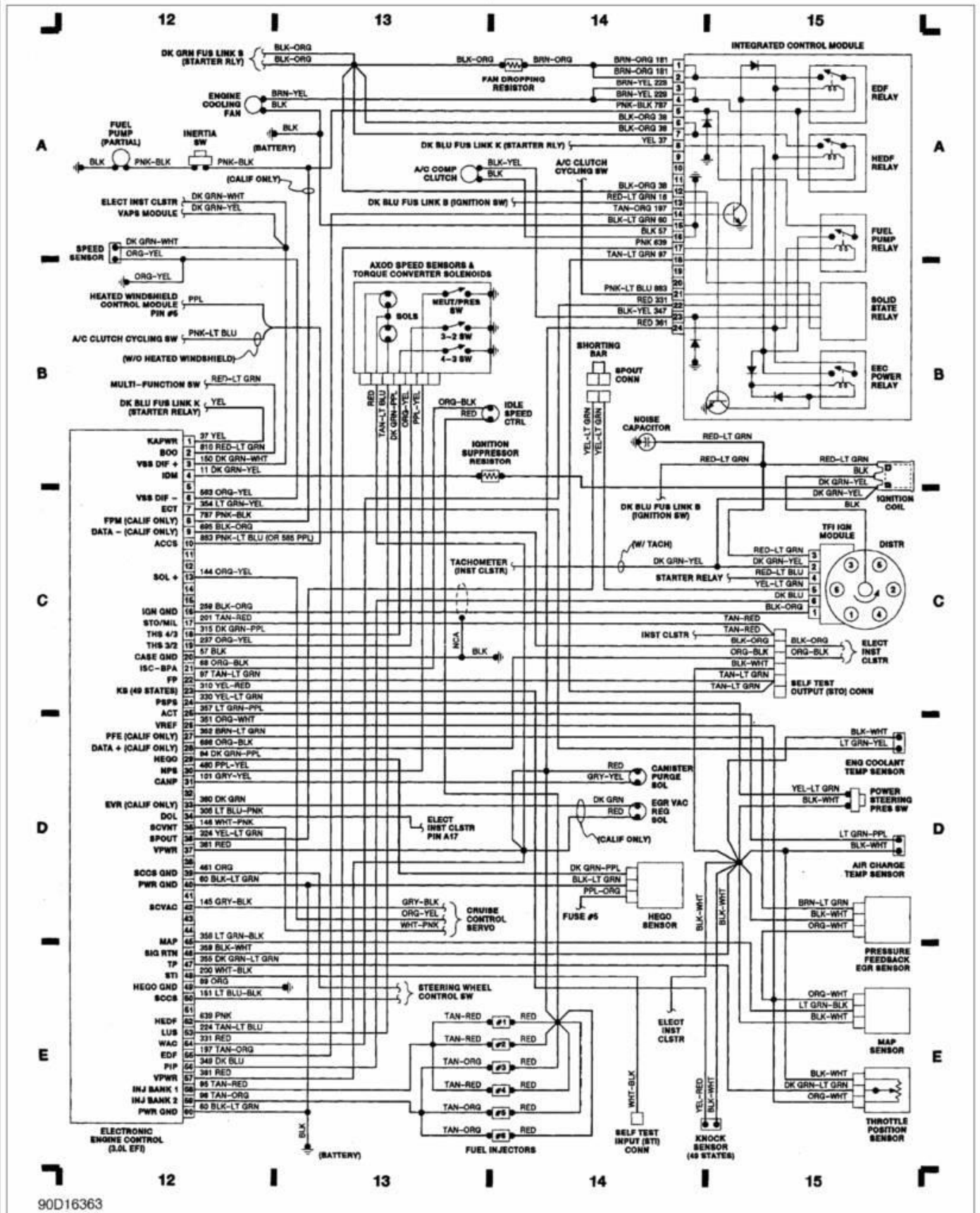

90D16363

WIRING DIAGRAMS

1990 Wiring Diagrams Ford Motor Co.

PAVLIN

Fig. 6: Engine Sensors (Grid 20-23)
1990 Ford Taurus LX

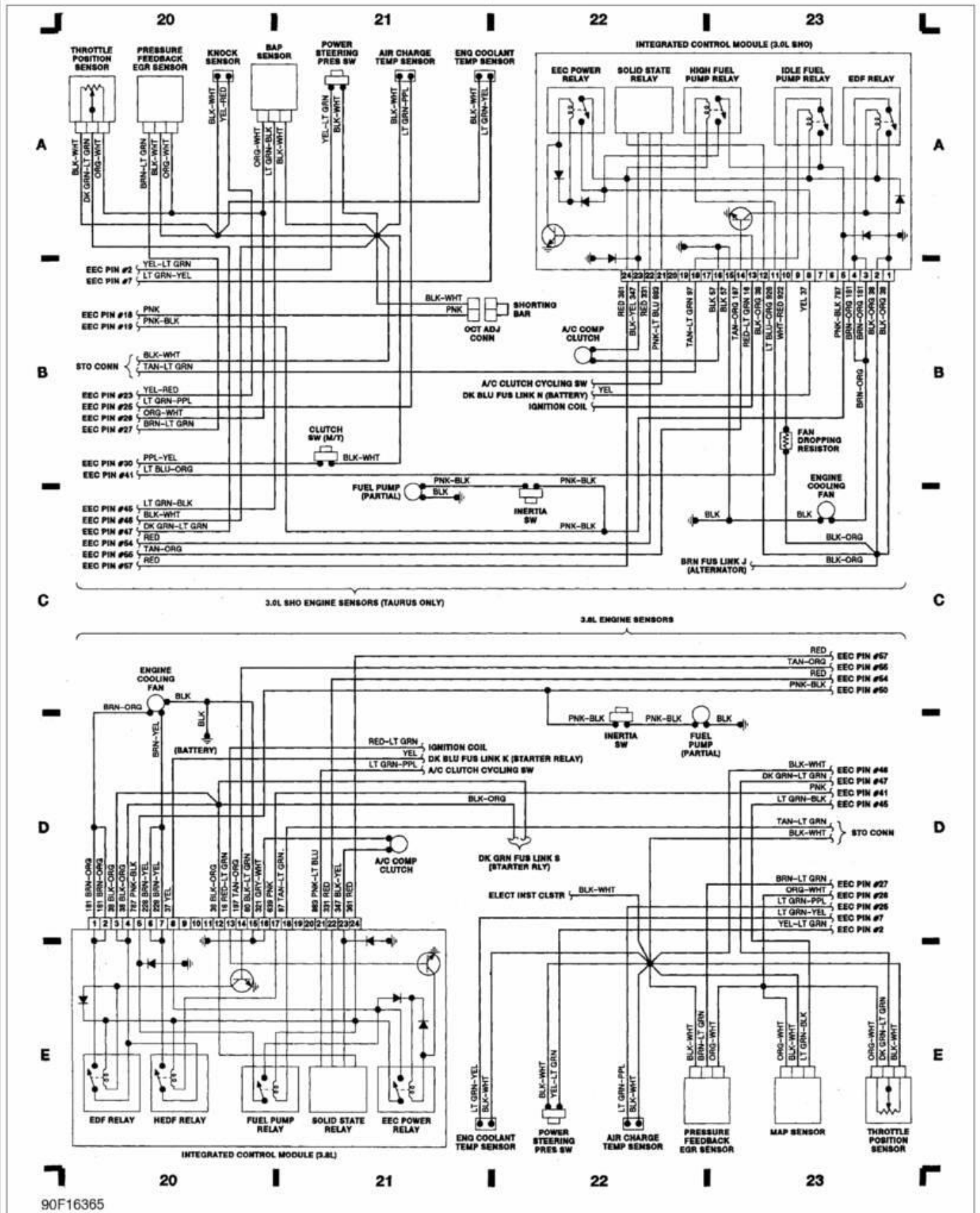

90F16365

WIRING DIAGRAMS

1990 Wiring Diagrams Ford Motor Co.

PAVLIN

Fig. 7: Electronic Engine Control (3.8L) (Grid 24-27)
1990 Ford Taurus LX

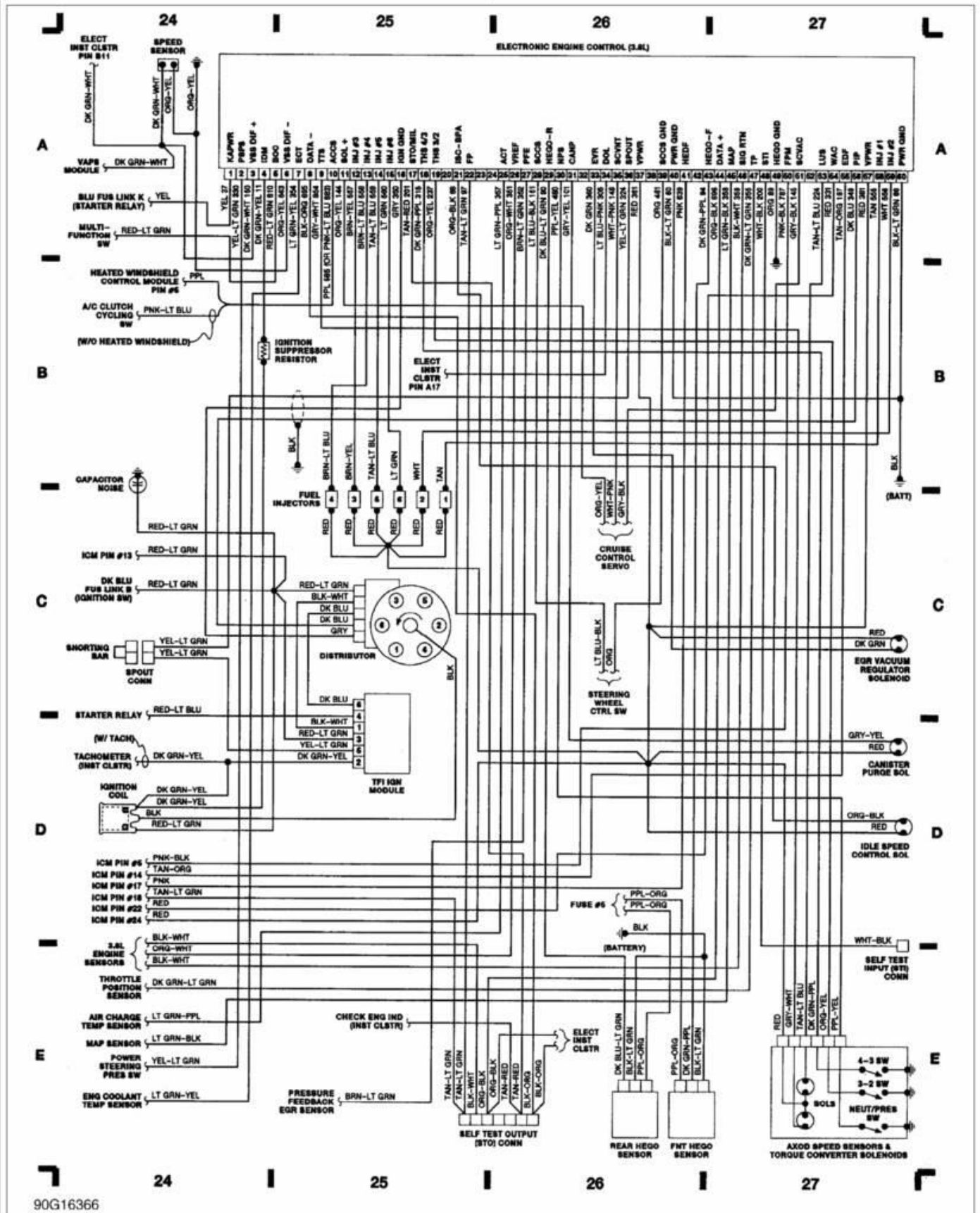

WIRING DIAGRAMS

1990 Wiring Diagrams Ford Motor Co.

PAVLIN

Fig. 10: EATC Control Module (Grid 36-39)
1990 Ford Taurus LX

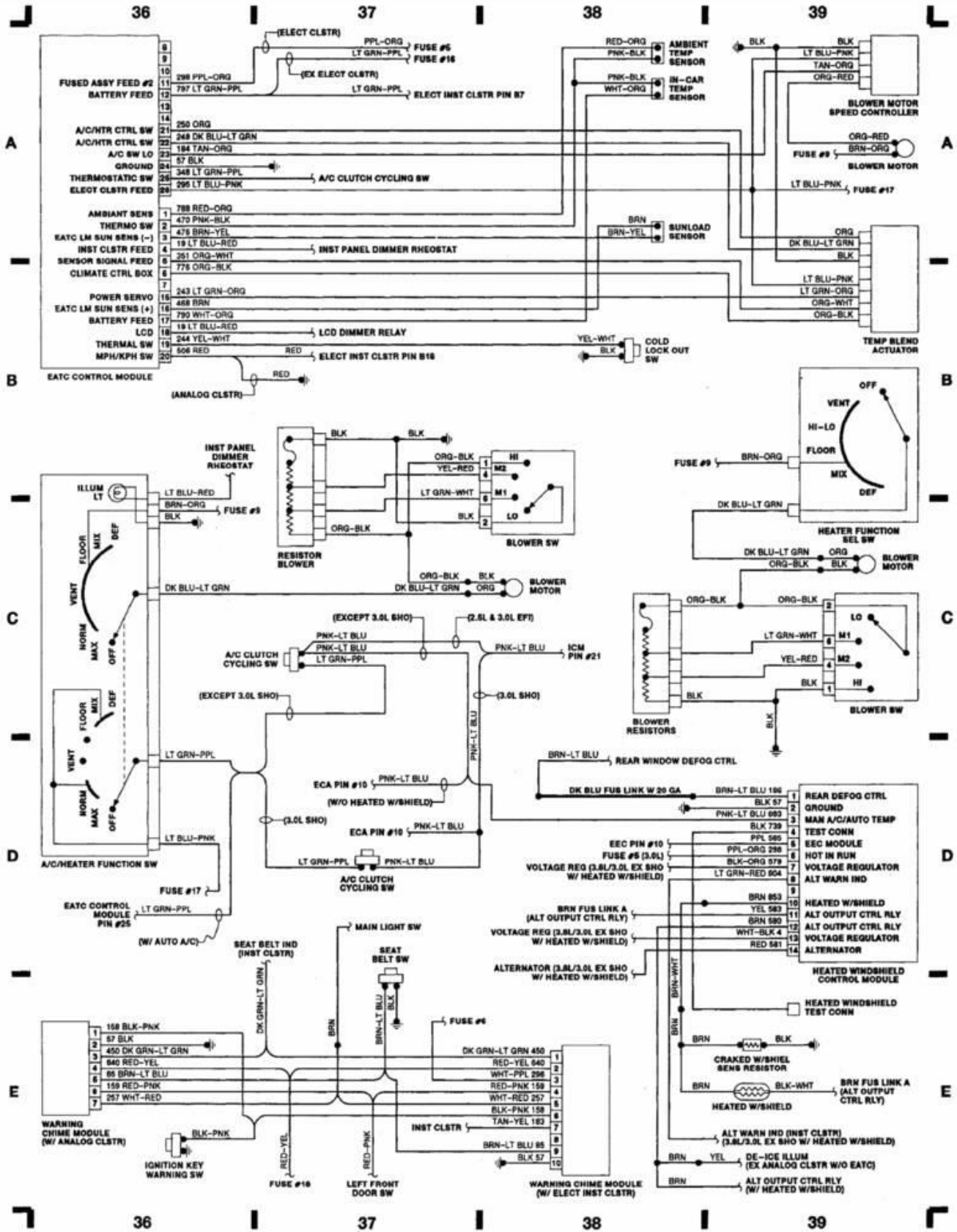

90J16369

WIRING DIAGRAMS

1990 Wiring Diagrams Ford Motor Co.

PAVLIN

Fig. 11: Multi-Function Switch (Grid 40-43)
1990 Ford Taurus LX

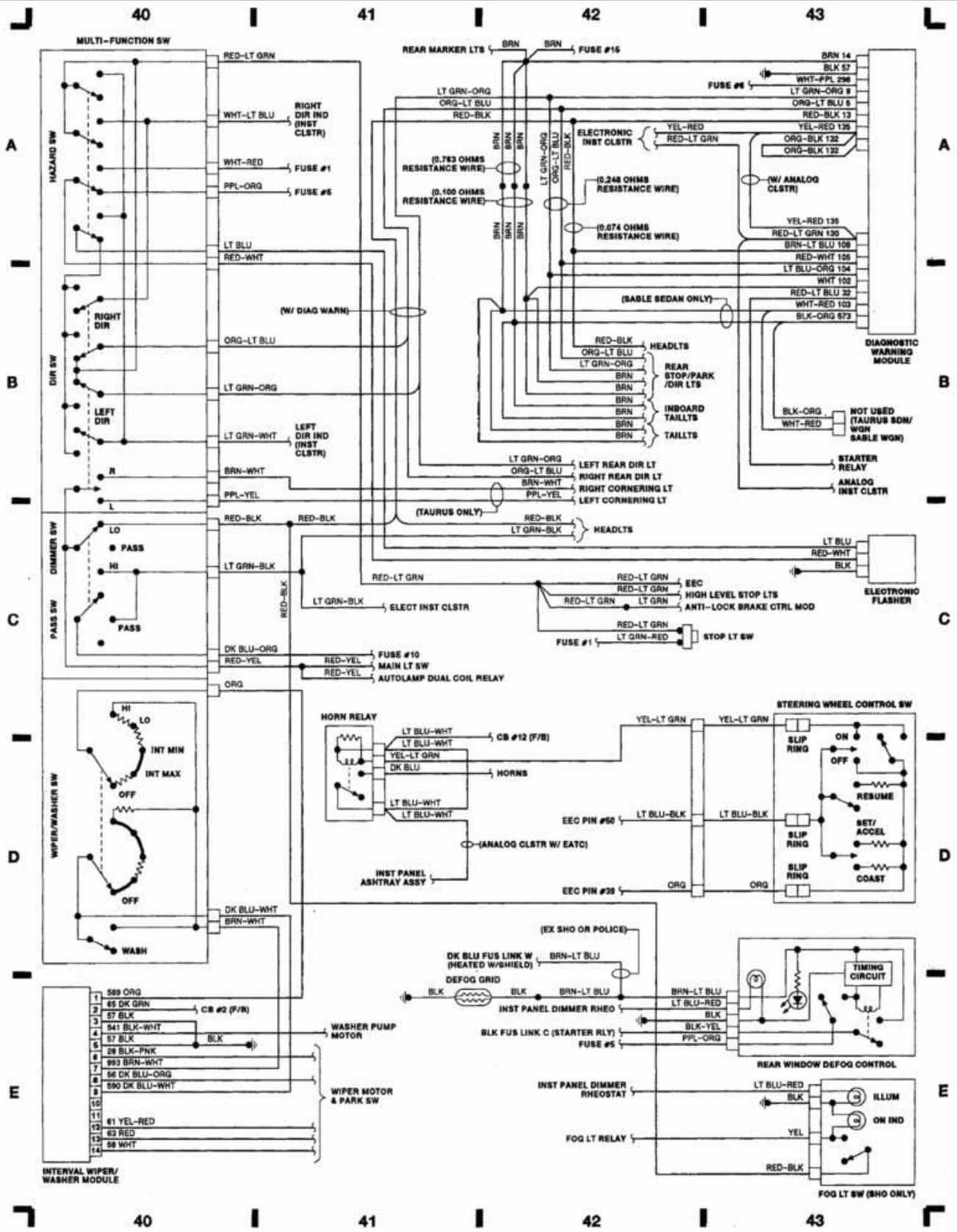

90C16370

WIRING DIAGRAMS
1990 Wiring Diagrams Ford Motor Co.

PAVLIN

Fig. 12: Passenger Compartment (Grid 44-47)
 1990 Ford Taurus LX

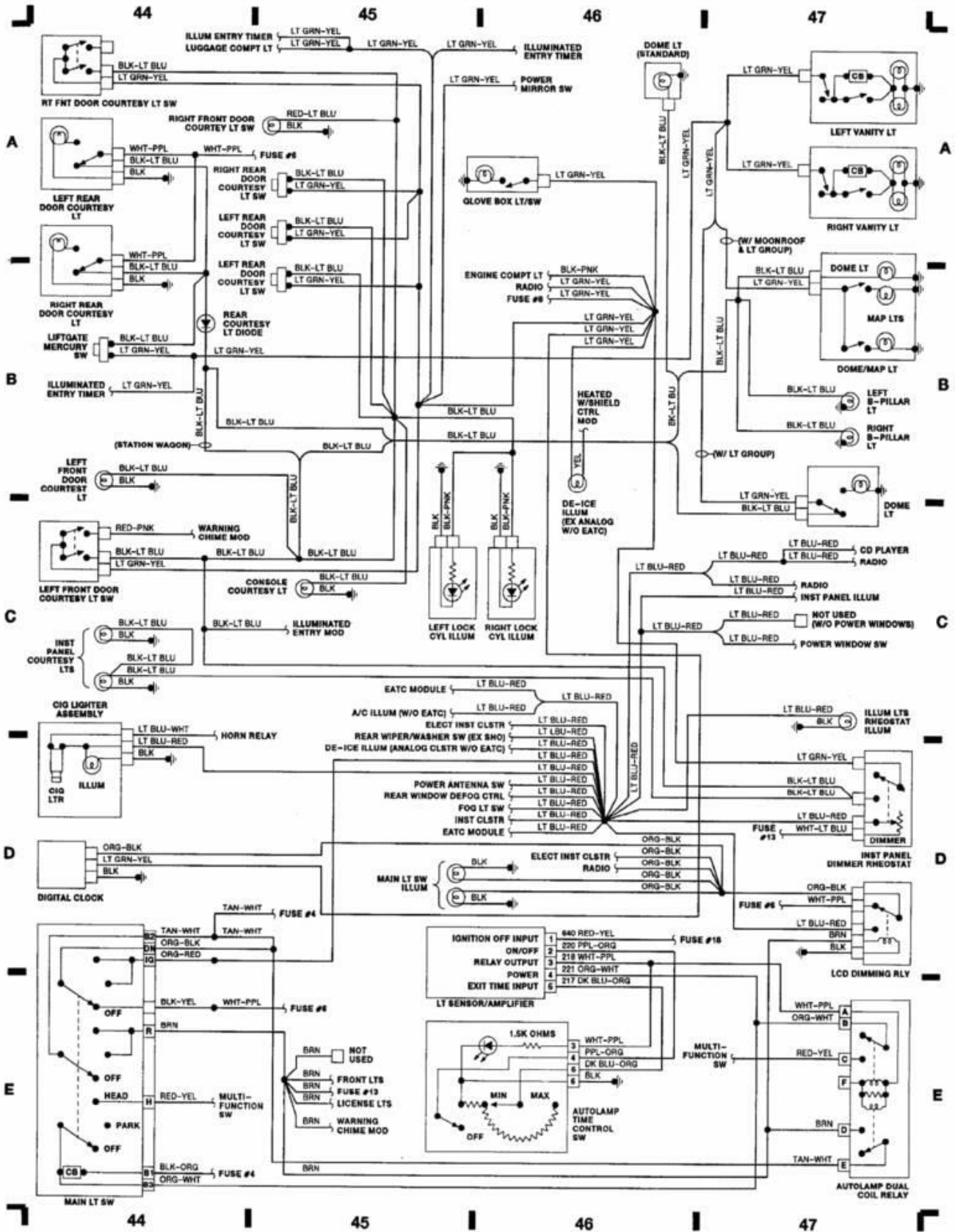

90D16371

WIRING DIAGRAMS

1990 Wiring Diagrams Ford Motor Co.

PAVLIN

Fig. 13: Instrument Clusters (Grid 48-51)
1990 Ford Taurus LX

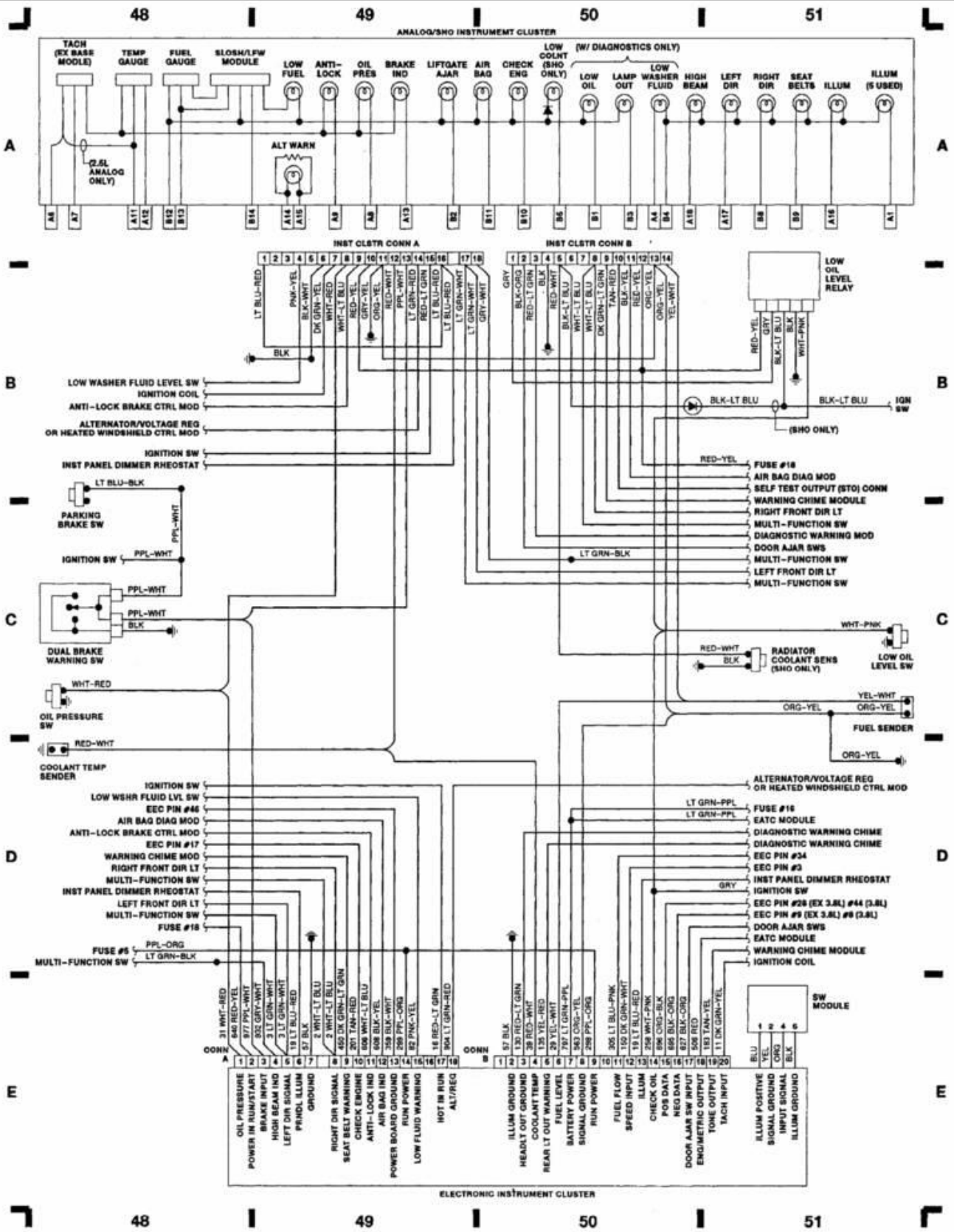

90E16372

WIRING DIAGRAMS
1990 Wiring Diagrams Ford Motor Co.

PAVLIN

Fig. 14: Keyless Entry Module & Power Seats (Grid 52-55)
1990 Ford Taurus LX

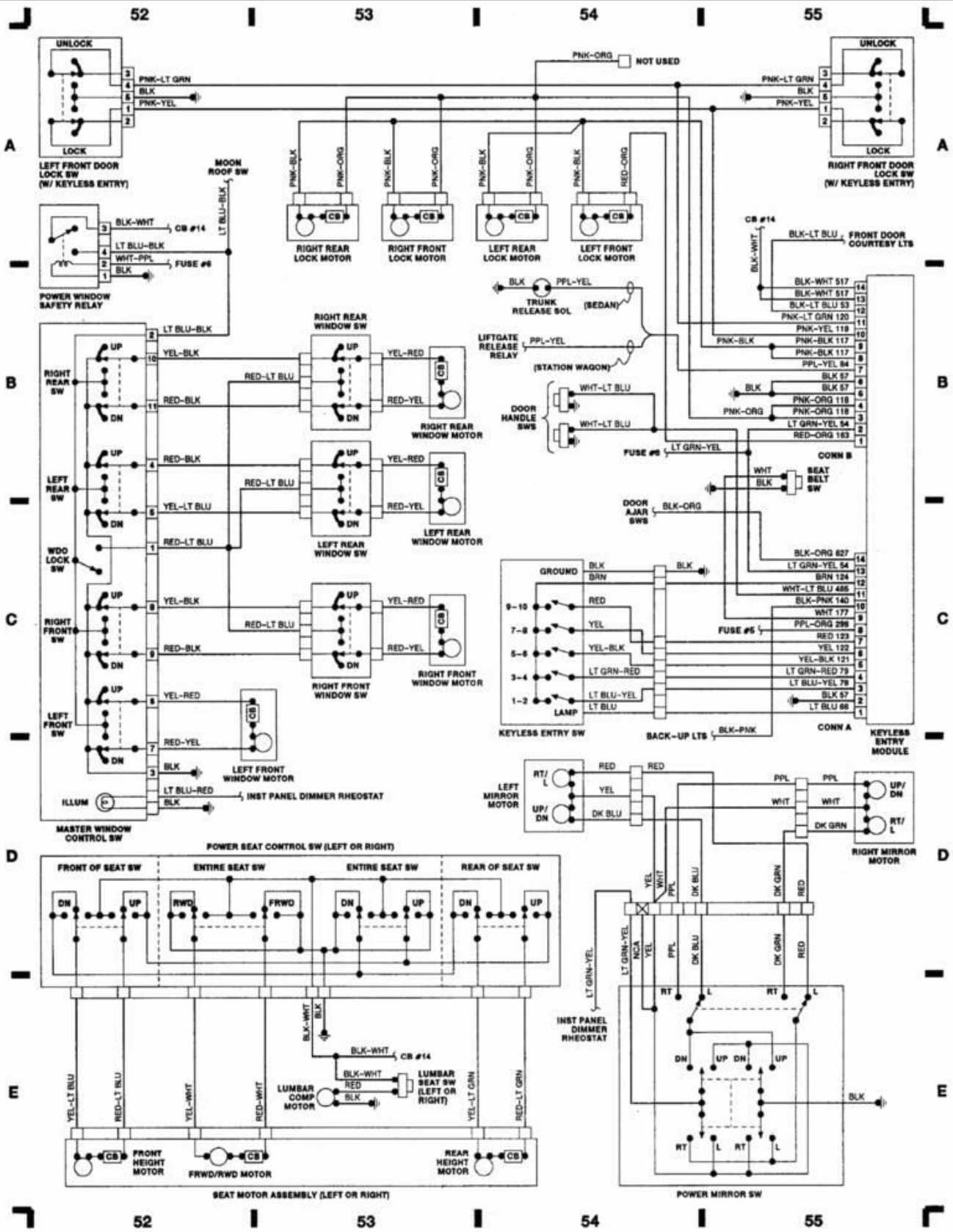

90F16373

WIRING DIAGRAMS

1990 Wiring Diagrams Ford Motor Co.

PAVLIN

Fig. 15: Passenger Compartment & Taillights (Grid 56-59)
1990 Ford Taurus LX

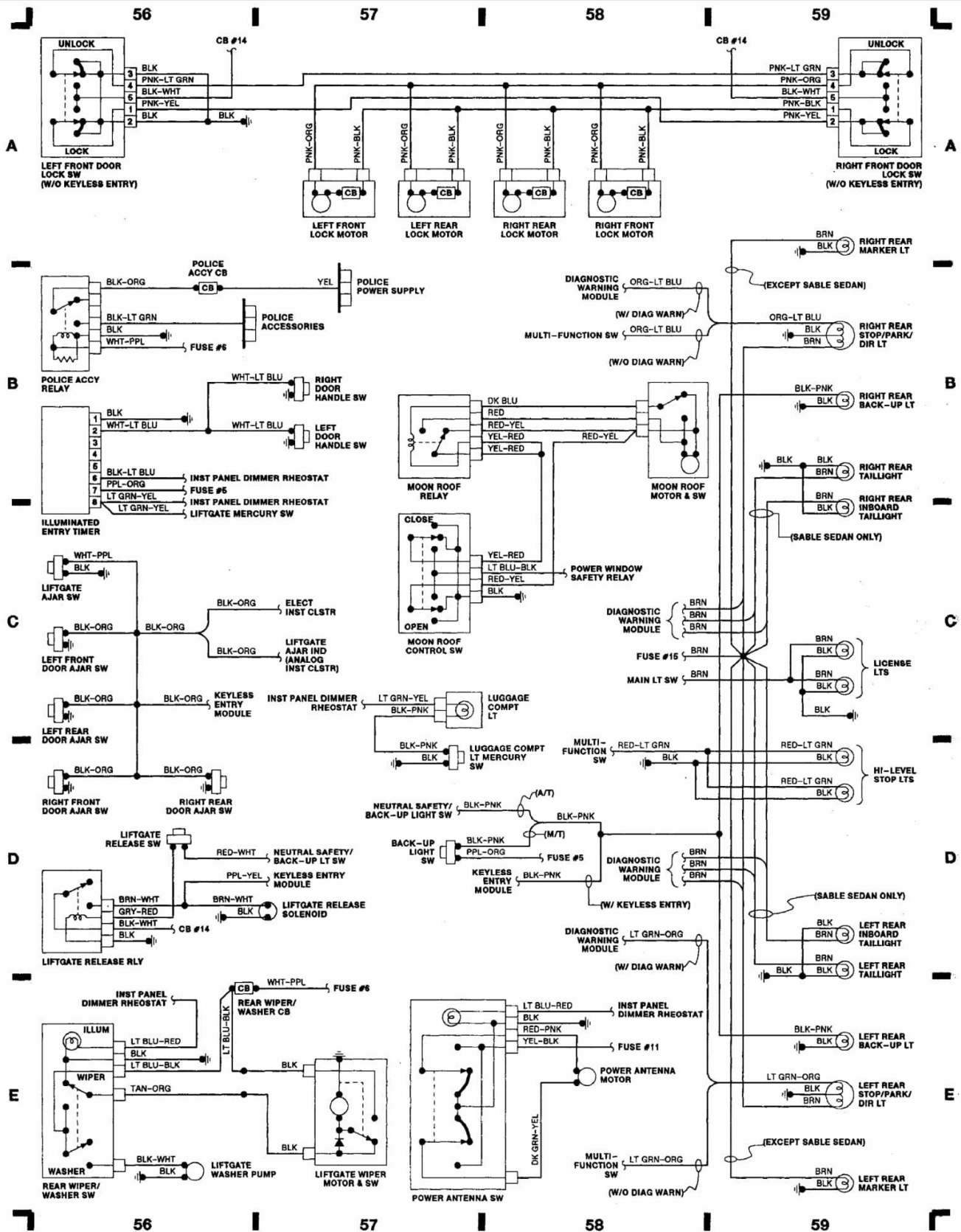

90G16374