

**1991 System Wiring Diagrams
Ford - Taurus**

PAVLIN

Fig. 1: 2.5L, Cooling Fan Circuit
1991 Ford Taurus LX

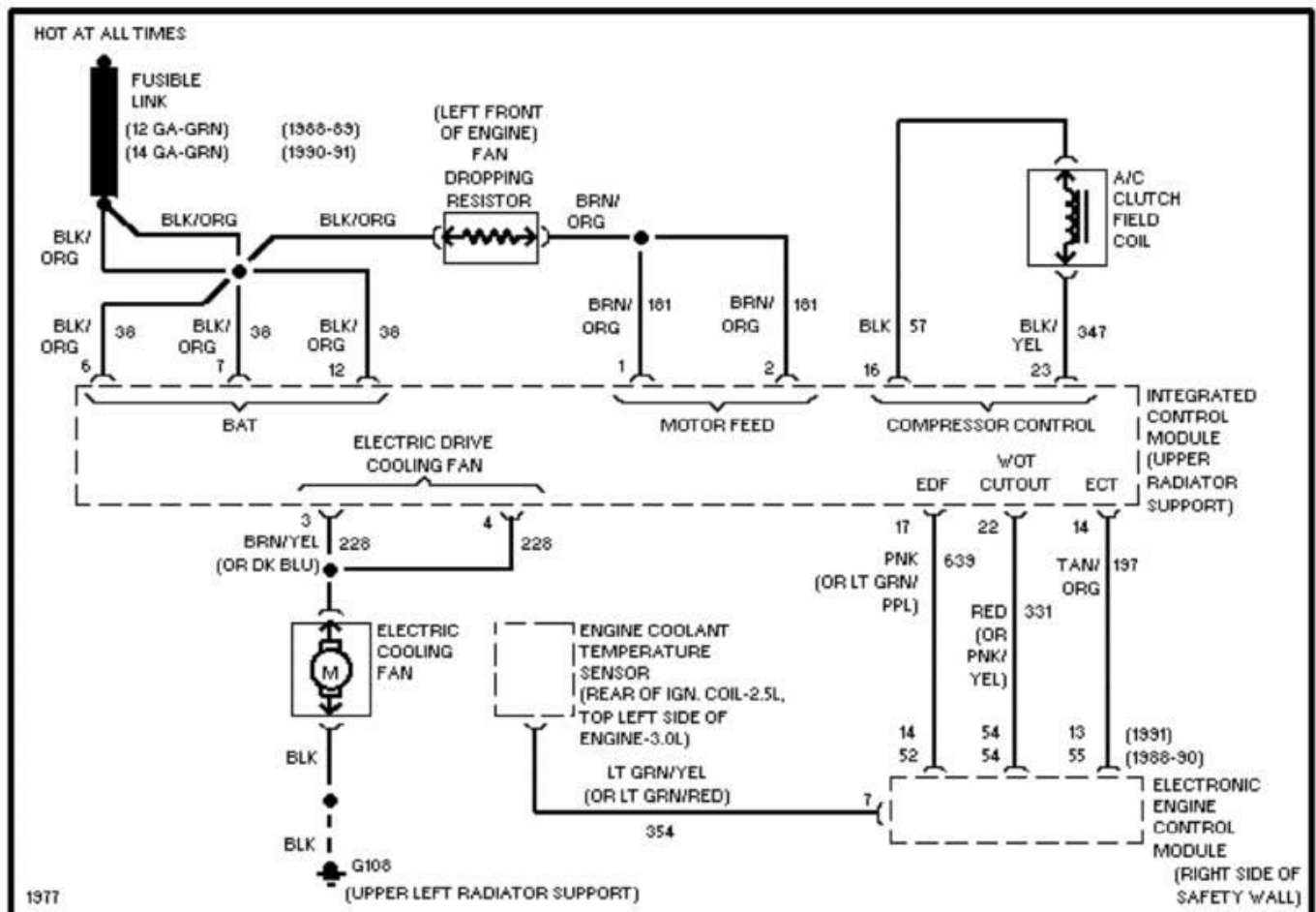

1991 System Wiring Diagrams
Ford - Taurus

PAVLIN

Fig. 2: 3.0L SHO, Cooling Fan Circuit
1991 Ford Taurus LX

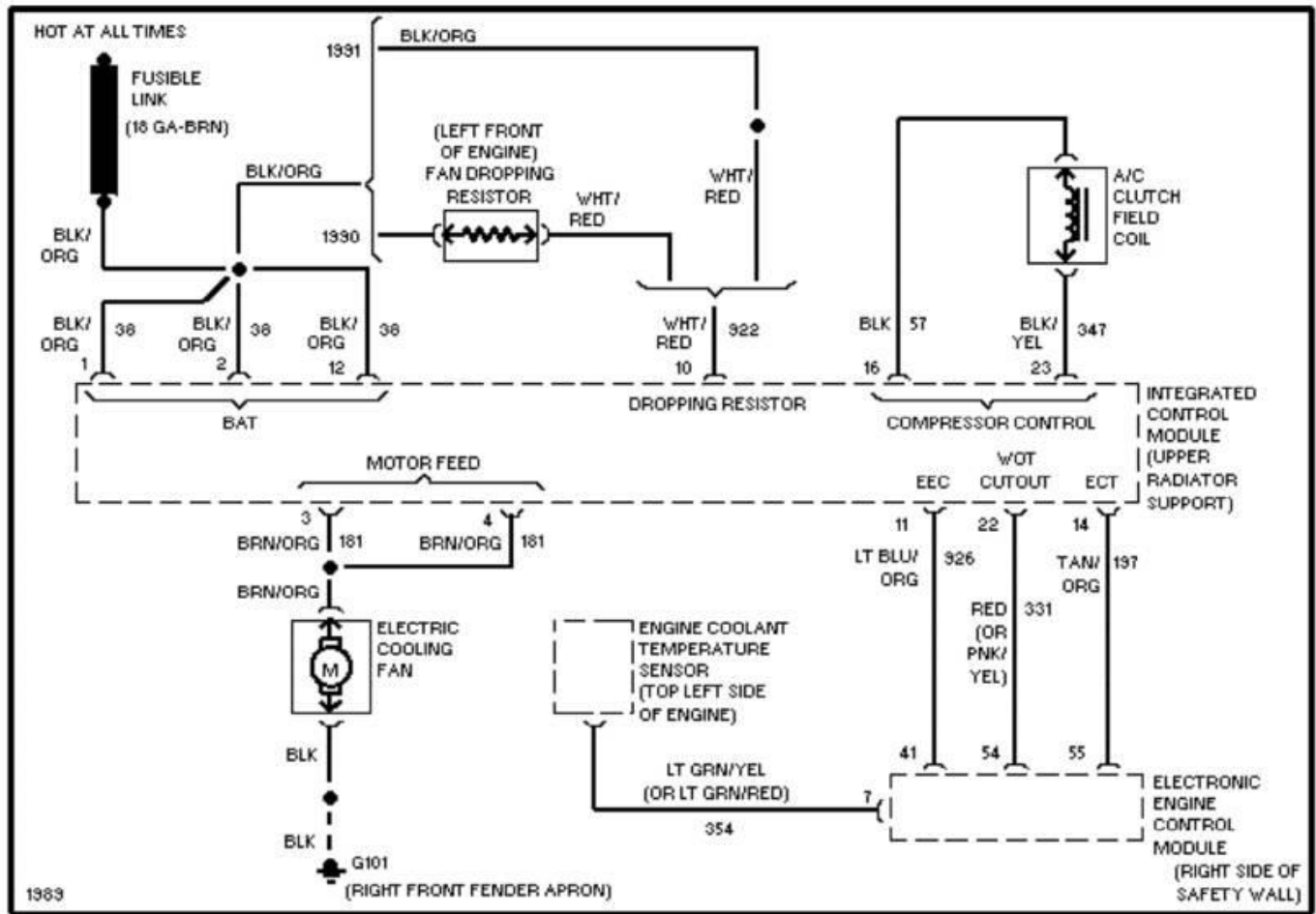

1991 System Wiring Diagrams
Ford - Taurus

PAVLIN

Fig. 3: 3.0L, Cooling Fan Circuit
1991 Ford Taurus LX

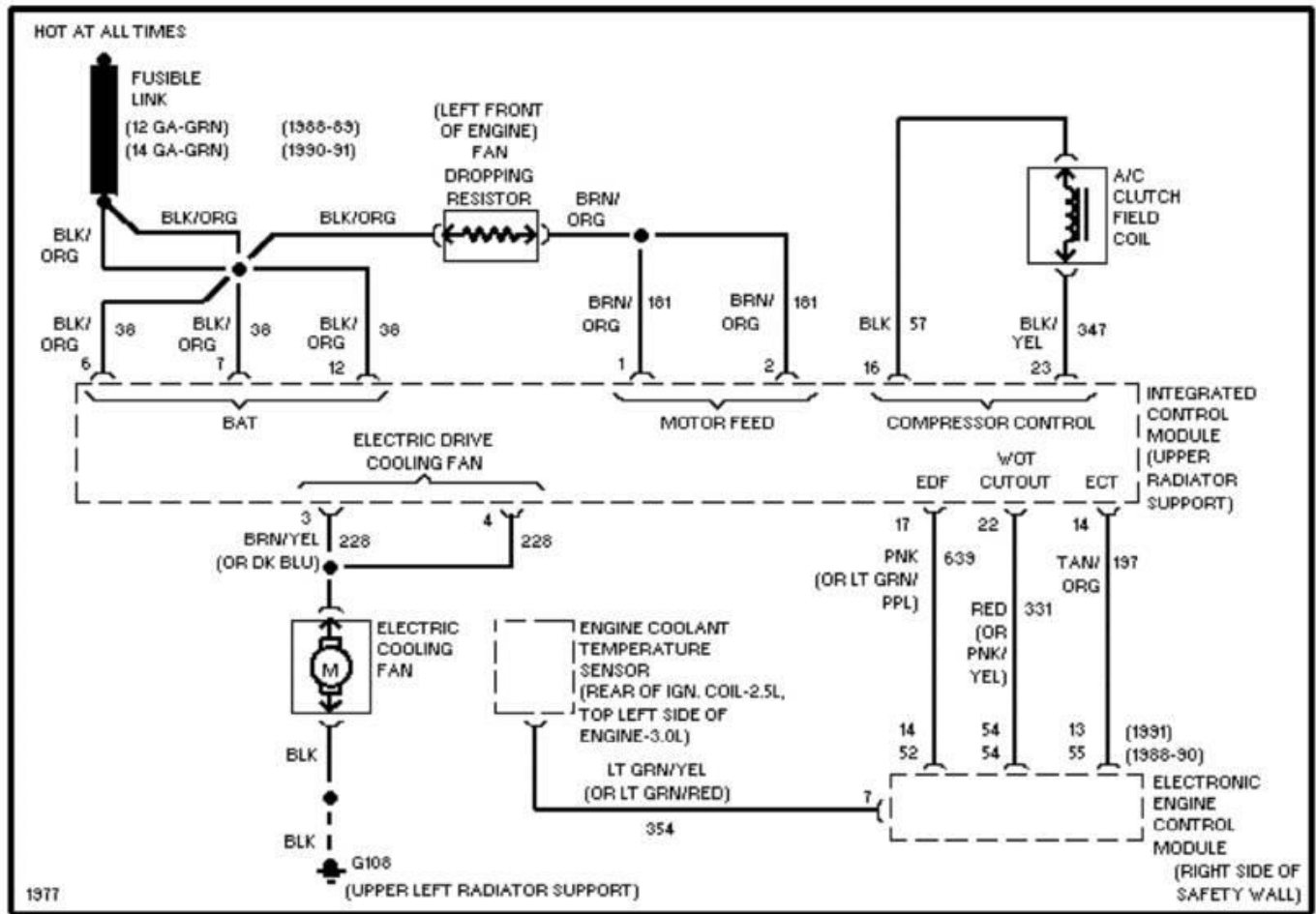

1991 System Wiring Diagrams
Ford - Taurus

PAVLIN

Fig. 4: 3.8L, Cooling Fan Circuit
1991 Ford Taurus LX

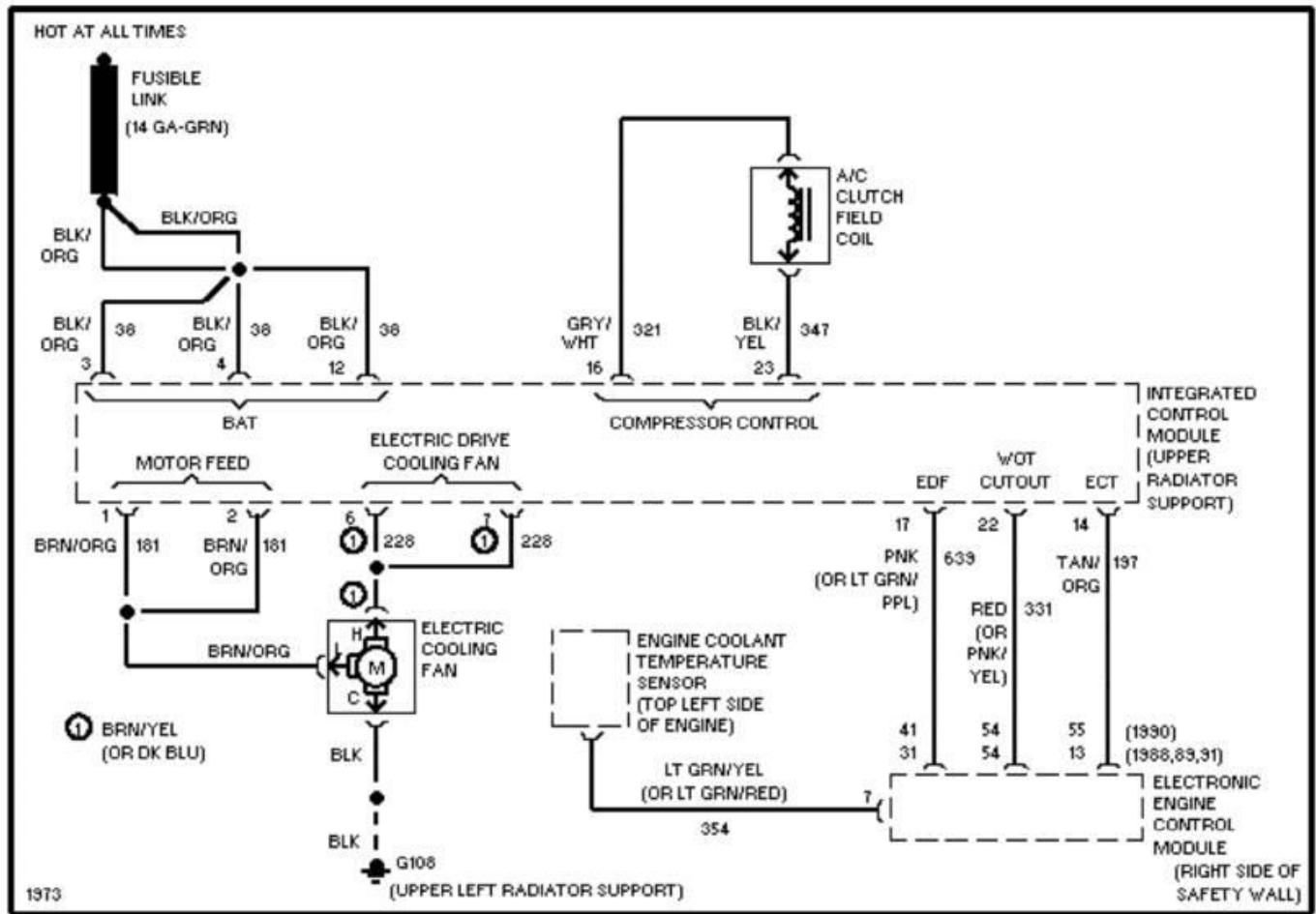

1991 System Wiring Diagrams Ford - Taurus

PAVLIN

Fig. 5: Defogger Circuit
1991 Ford Taurus LX

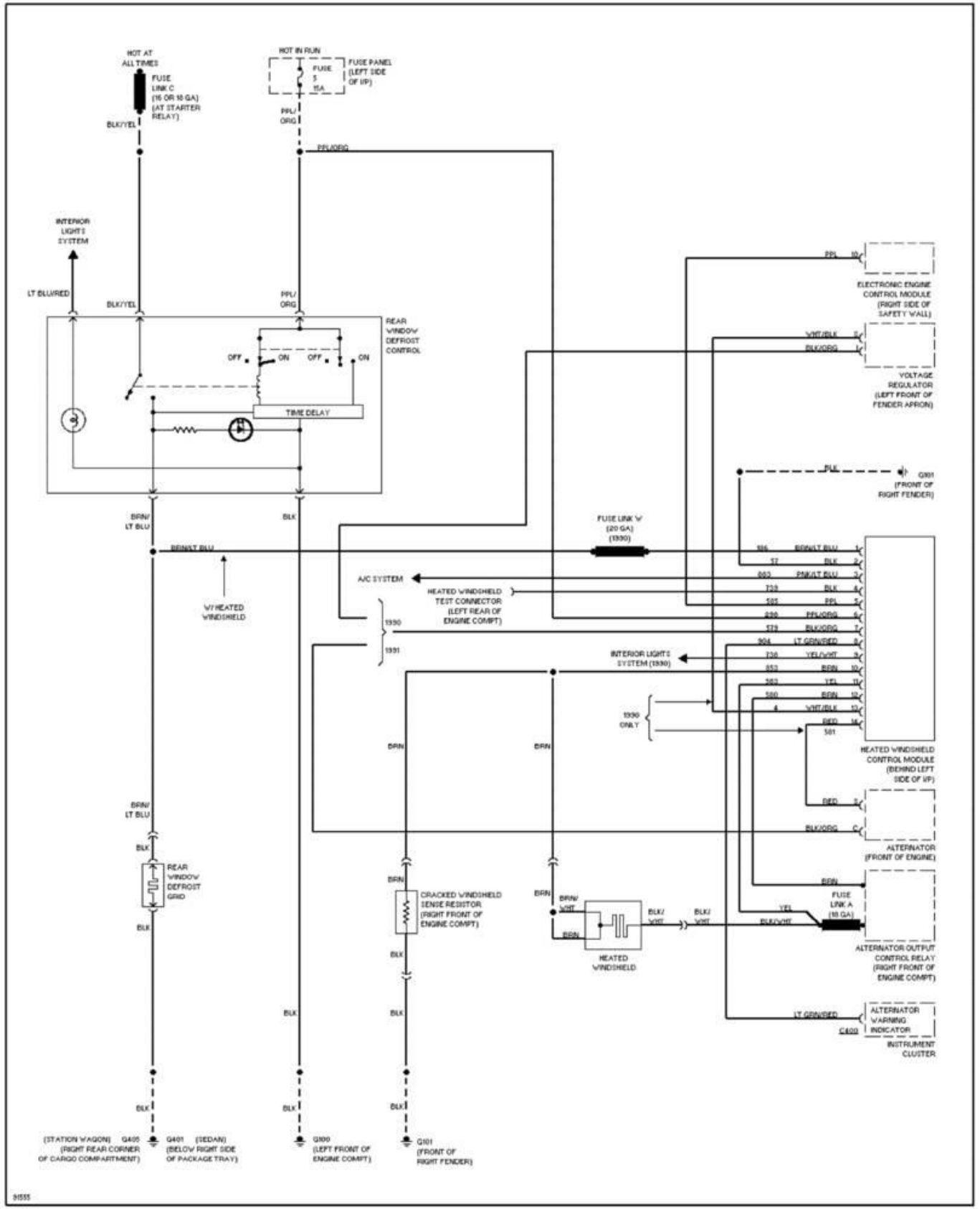

1991 System Wiring Diagrams
Ford - Taurus

PAVLIN

Fig. 6: Horn Circuit
1991 Ford Taurus LX

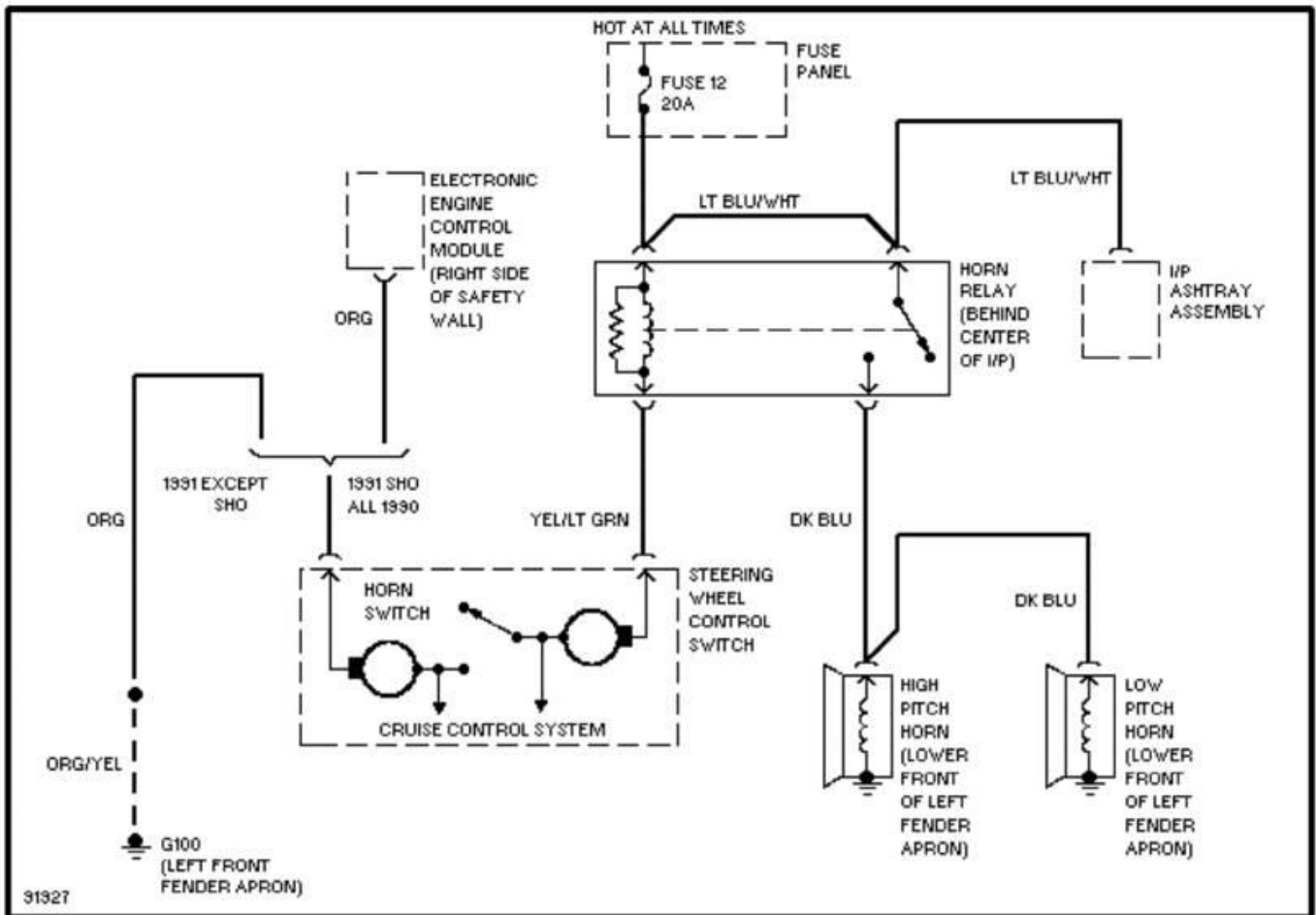

91327

1991 System Wiring Diagrams
Ford - Taurus

PAVLIN

Fig. 7: Power Antenna Circuit
1991 Ford Taurus LX

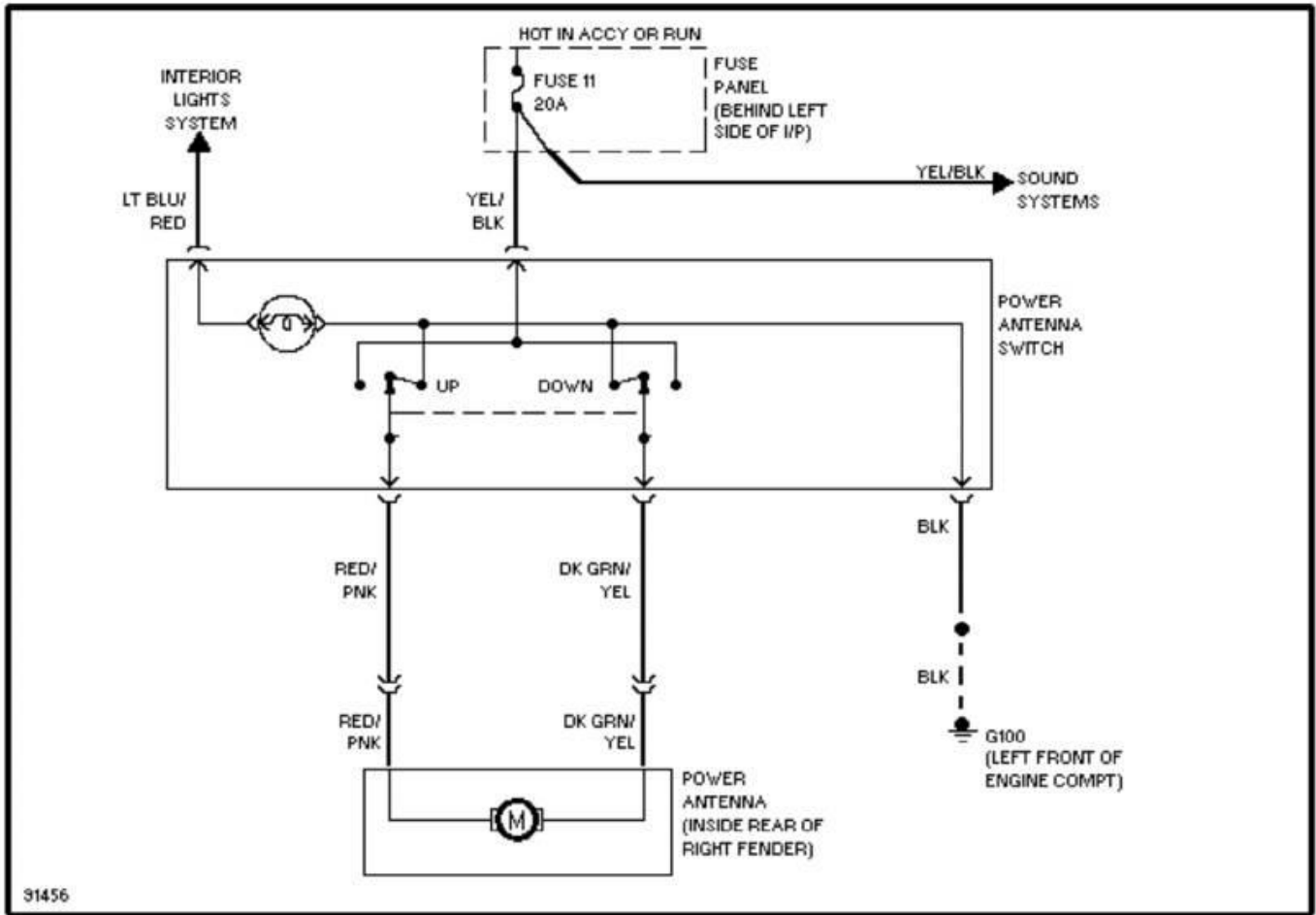

1991 System Wiring Diagrams
Ford - Taurus

PAVLIN

Fig. 8: Door Lock Circuit
1991 Ford Taurus LX

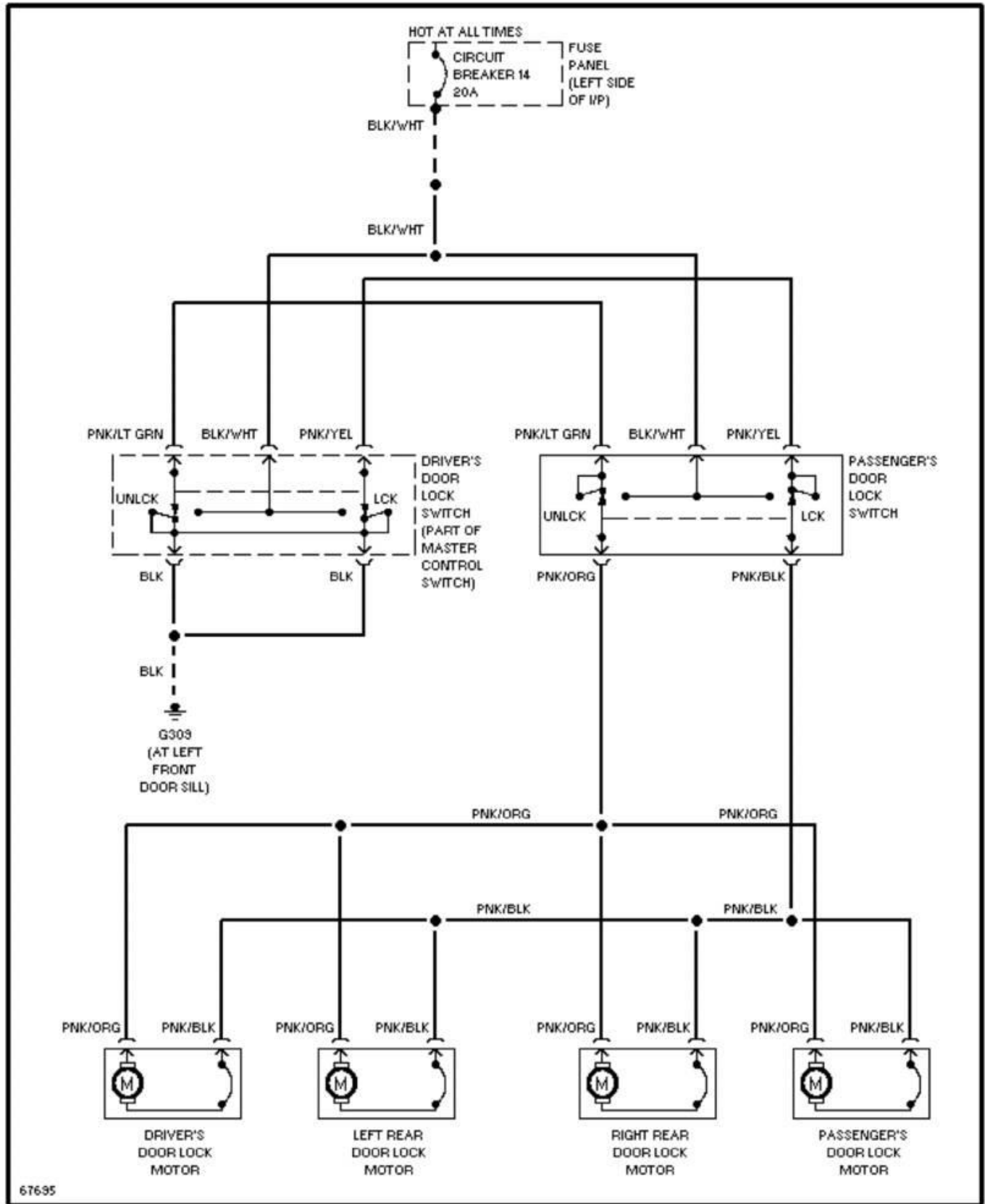

1991 System Wiring Diagrams Ford - Taurus

PAVLIN

Fig. 9: Keyless Entry Circuit
1991 Ford Taurus LX

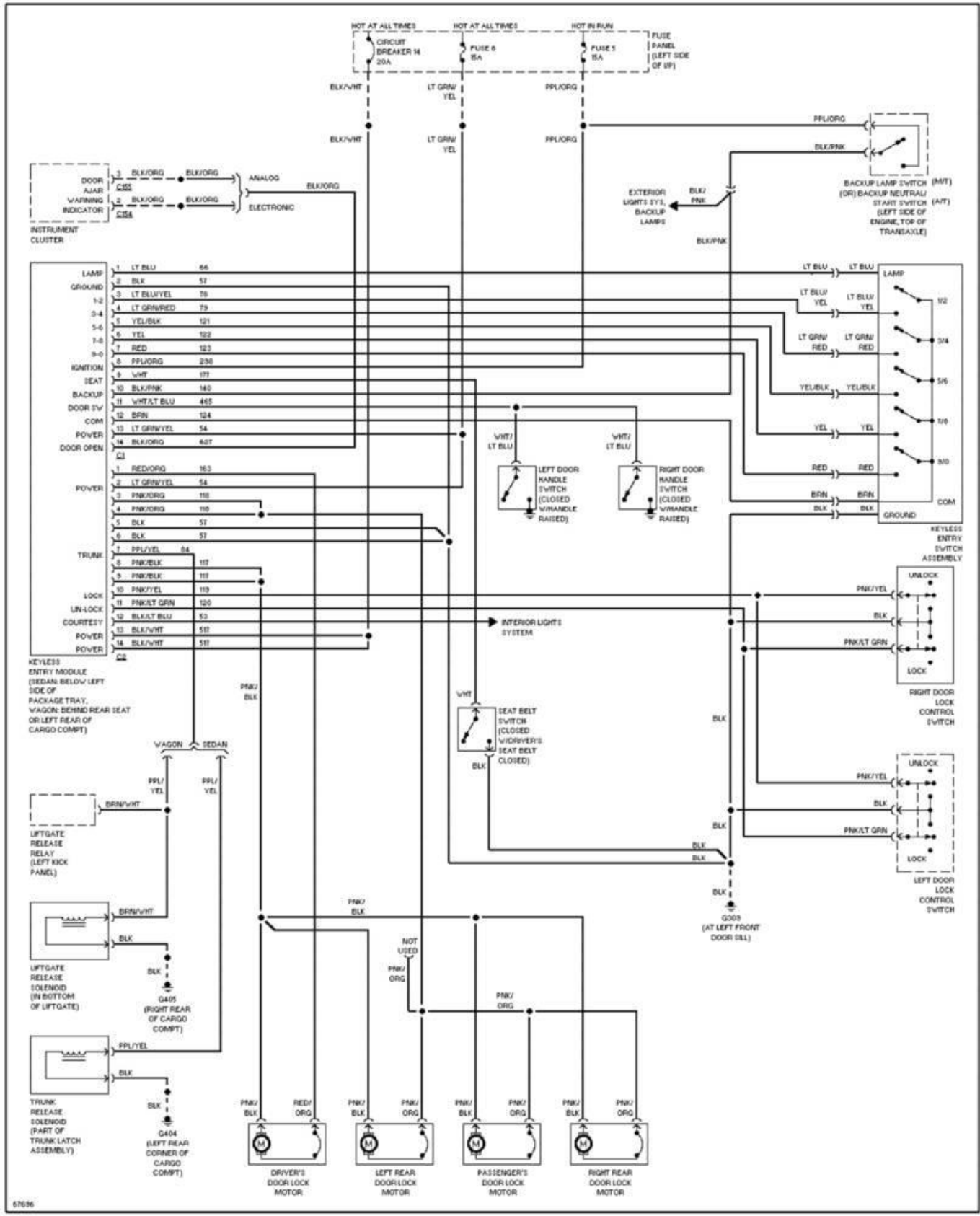

67636

1991 System Wiring Diagrams
Ford - Taurus

PAVLIN

Fig. 10: Power Mirror Circuit
1991 Ford Taurus LX

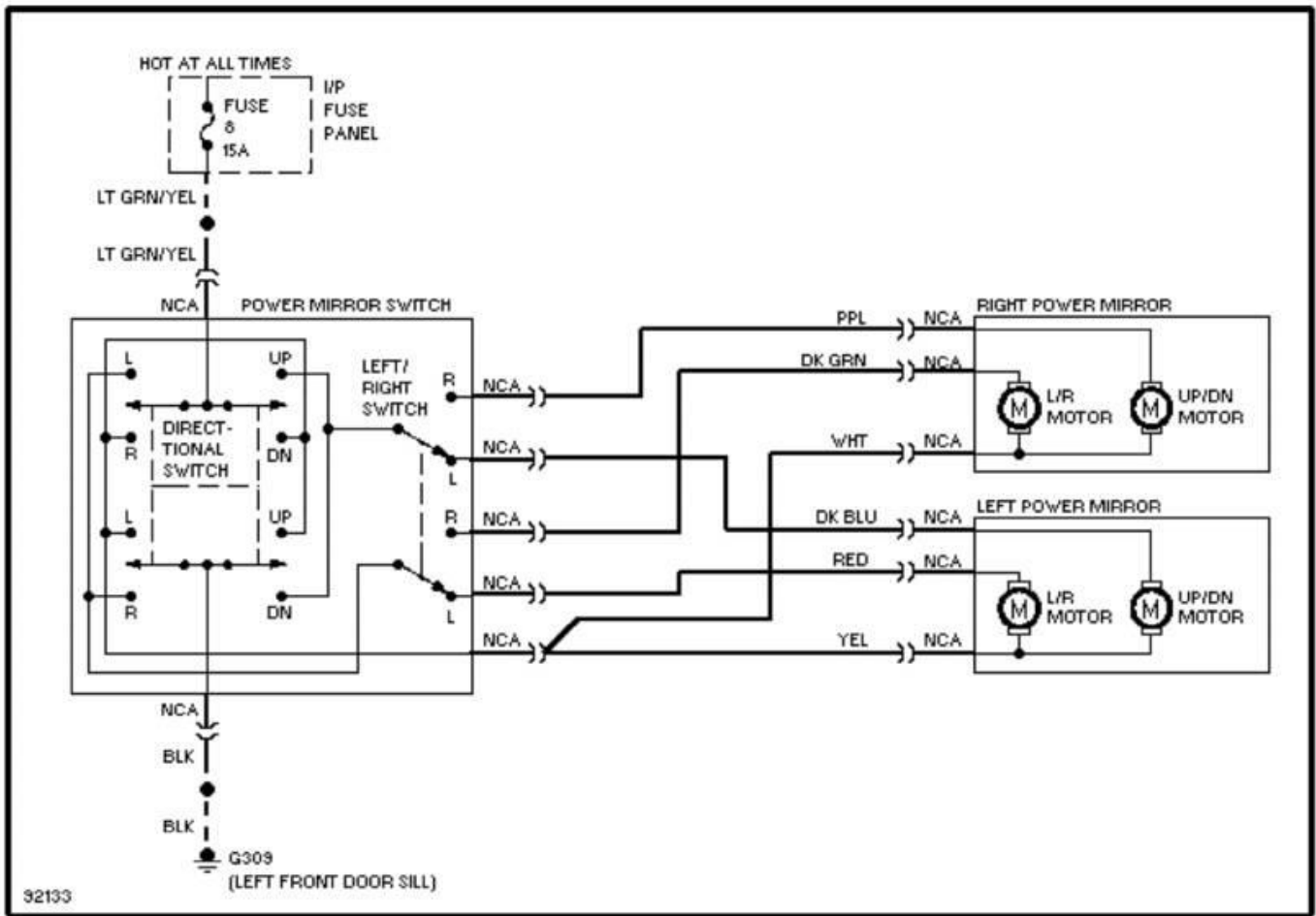

1991 System Wiring Diagrams
Ford - Taurus

PAVLIN

Fig. 11: Lumbar Circuit
1991 Ford Taurus LX

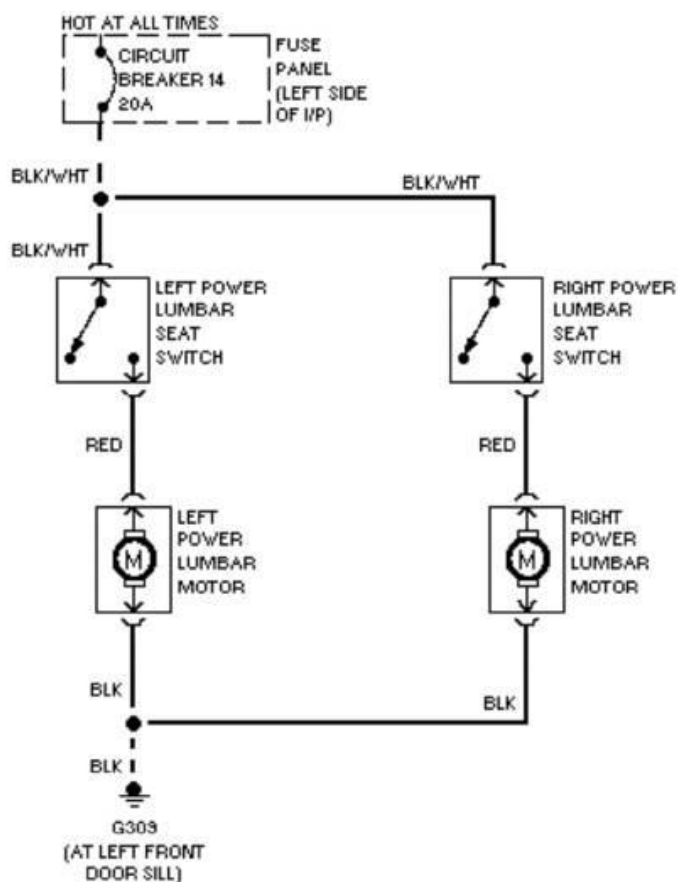

91736

1991 System Wiring Diagrams
Ford - Taurus

PAVLIN

Fig. 12: Power Seat Circuit
1991 Ford Taurus LX

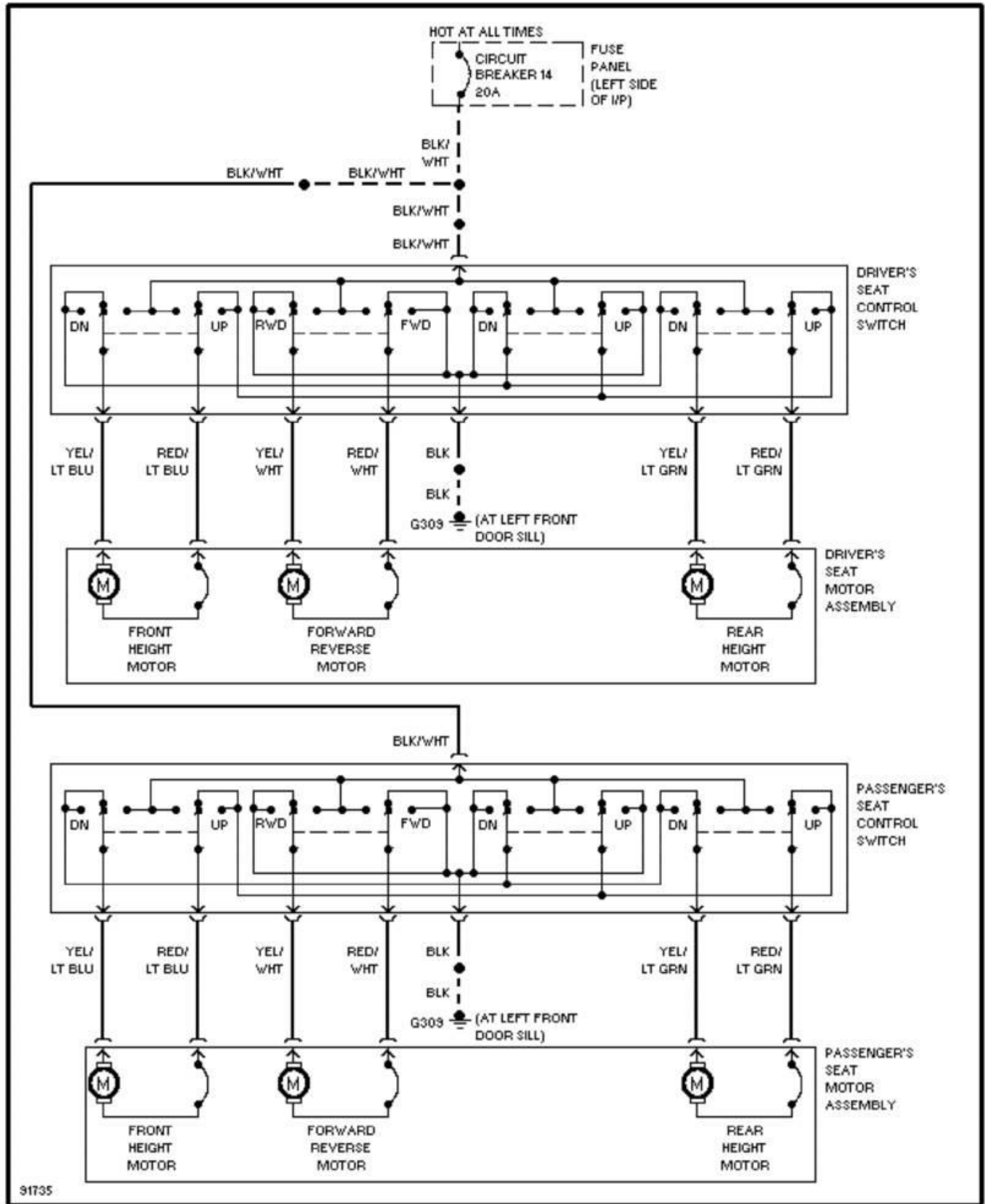

1991 System Wiring Diagrams Ford - Taurus

PAVLIN

Fig. 13: Power Window Circuit
1991 Ford Taurus LX

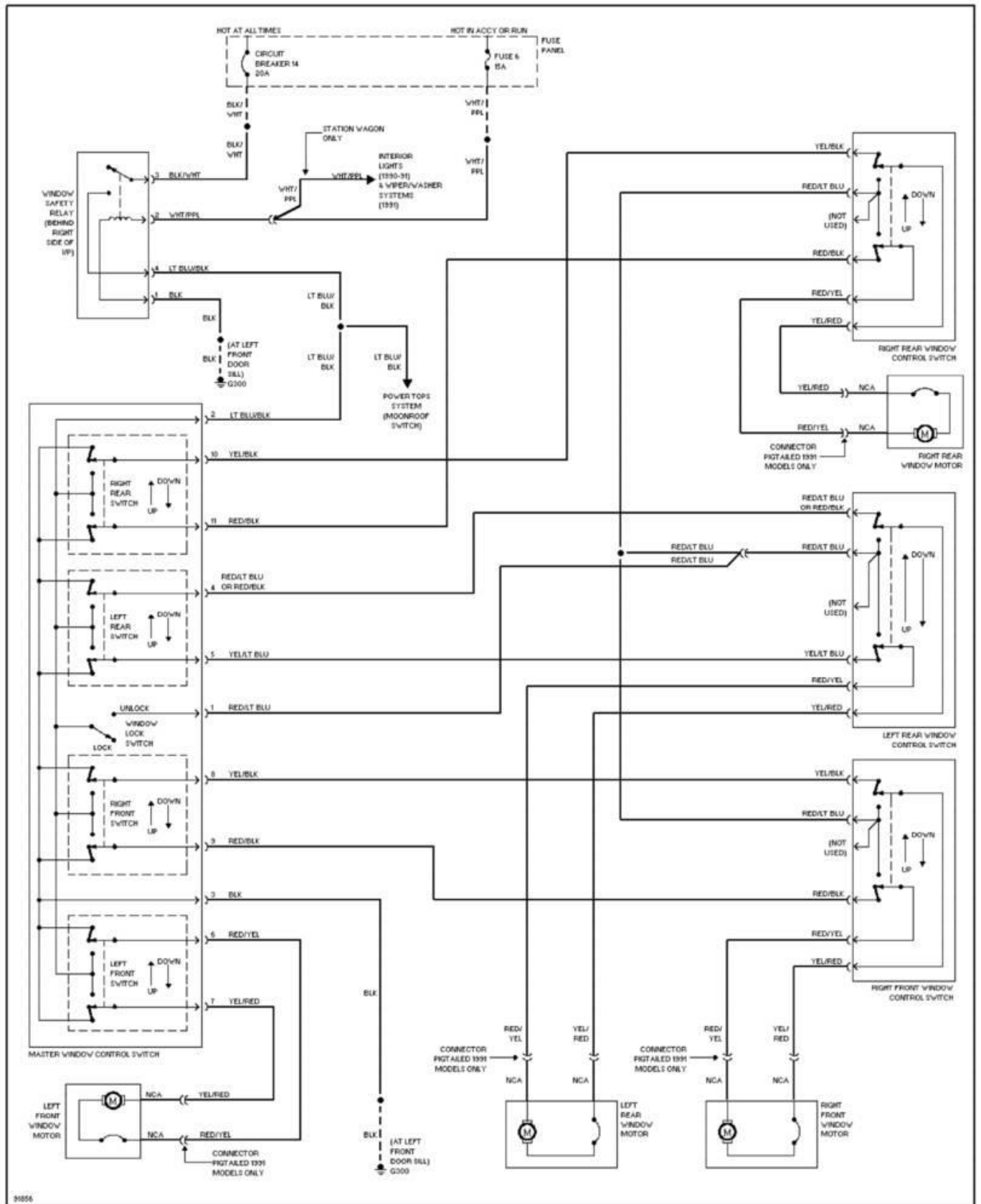

91856

1991 System Wiring Diagrams
Ford - Taurus

PAVLIN

Fig. 14: Radio Circuits
1991 Ford Taurus LX

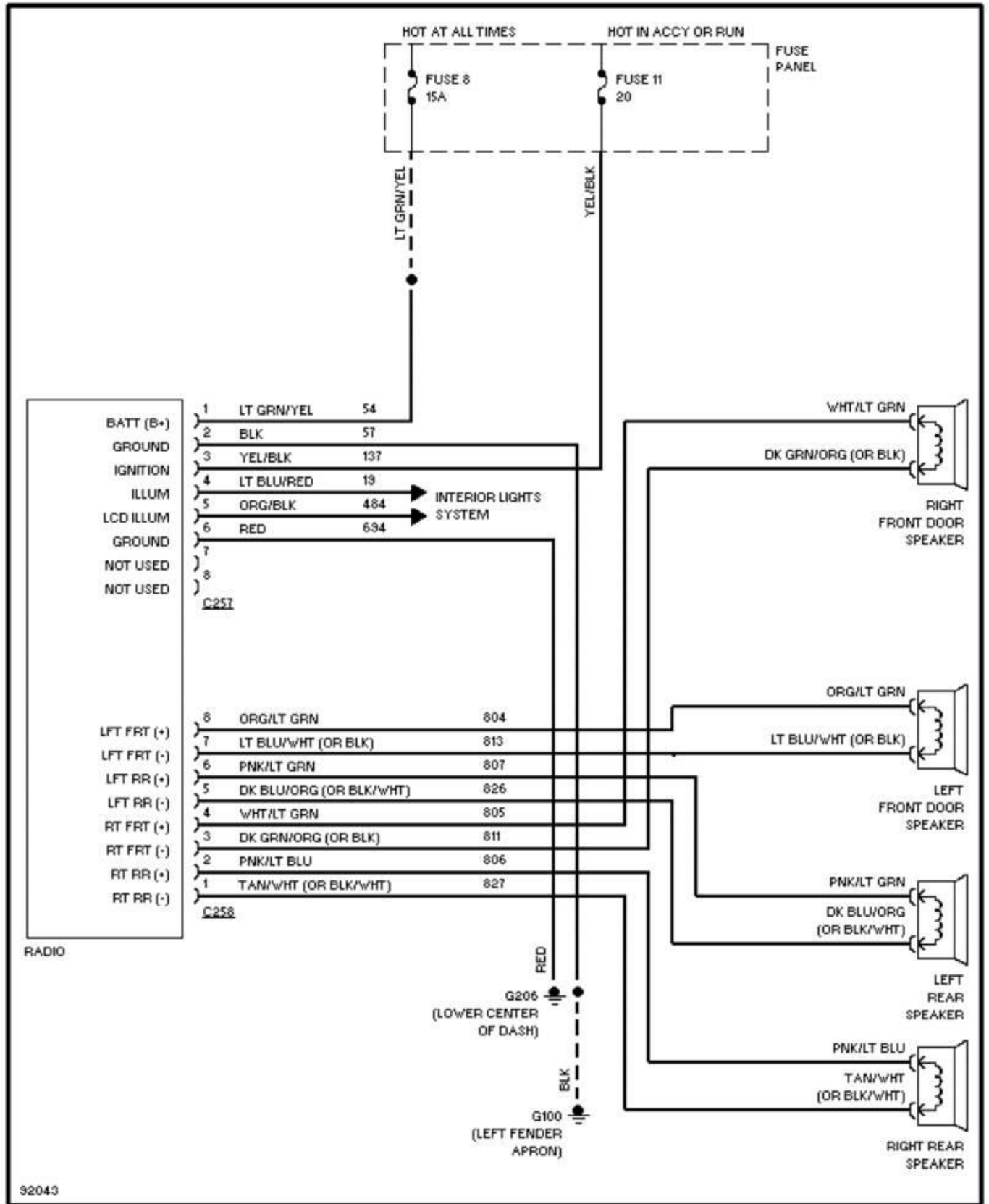

92043

1991 System Wiring Diagrams Ford - Taurus

PAVLIN

Fig. 15: Radio Circuits, JBL System
1991 Ford Taurus LX

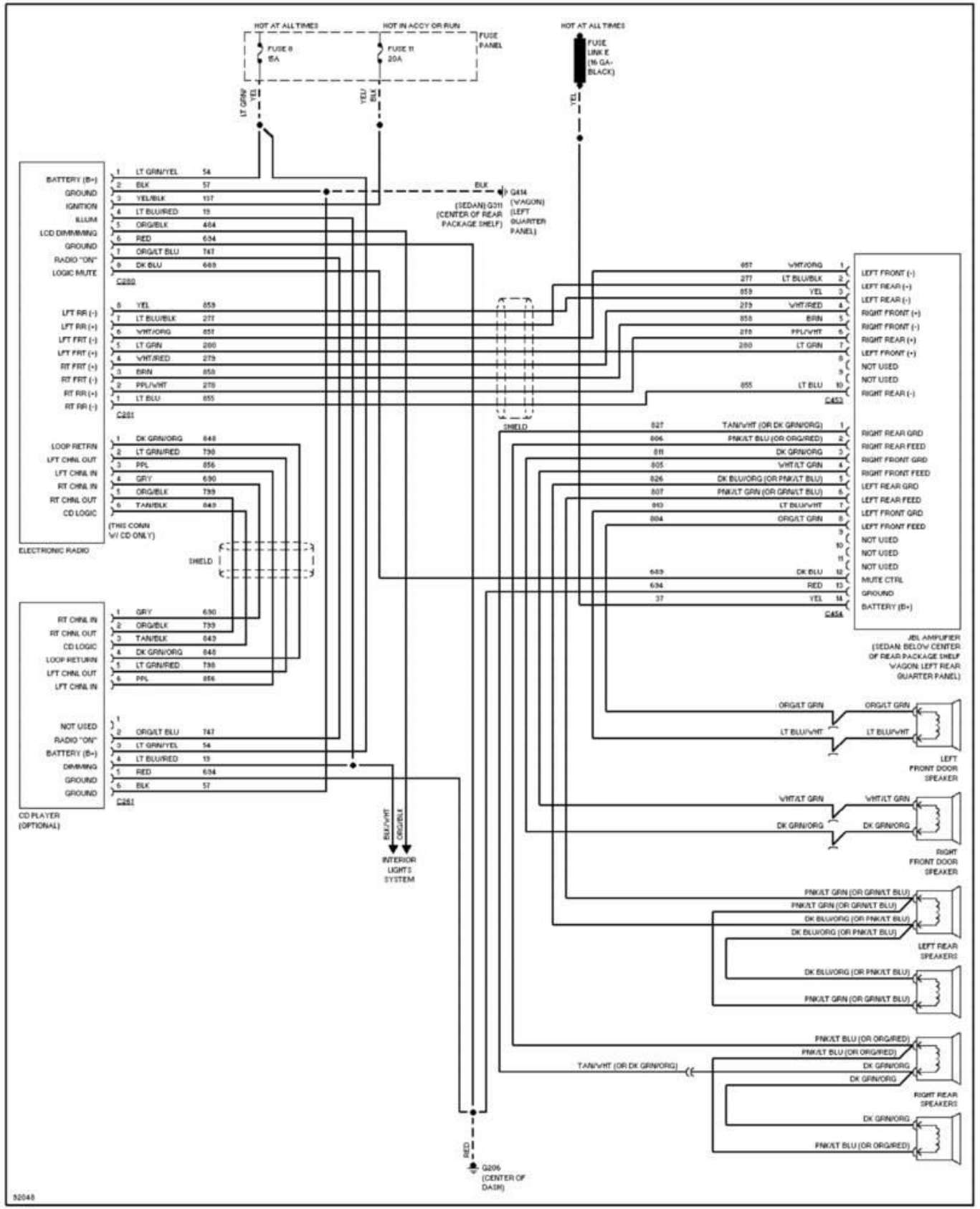

92048

1991 System Wiring Diagrams Ford - Taurus

PAVLIN

Fig. 16: Radio Circuits, Premium Radio
1991 Ford Taurus LX

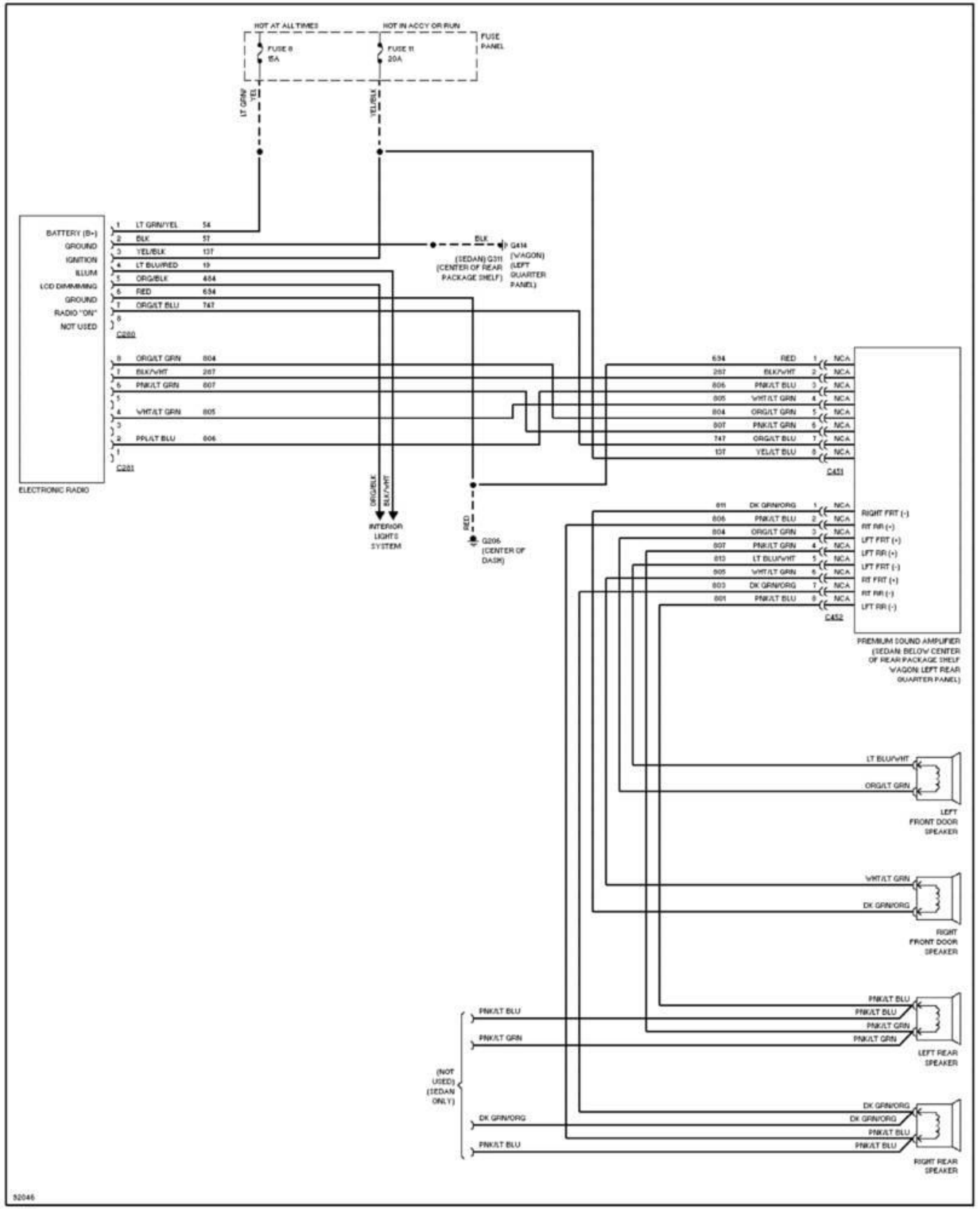

92046

1991 System Wiring Diagrams
Ford - Taurus

PAVLIN

Fig. 17: Charging Circuit, W/ Heated Windshield
1991 Ford Taurus LX

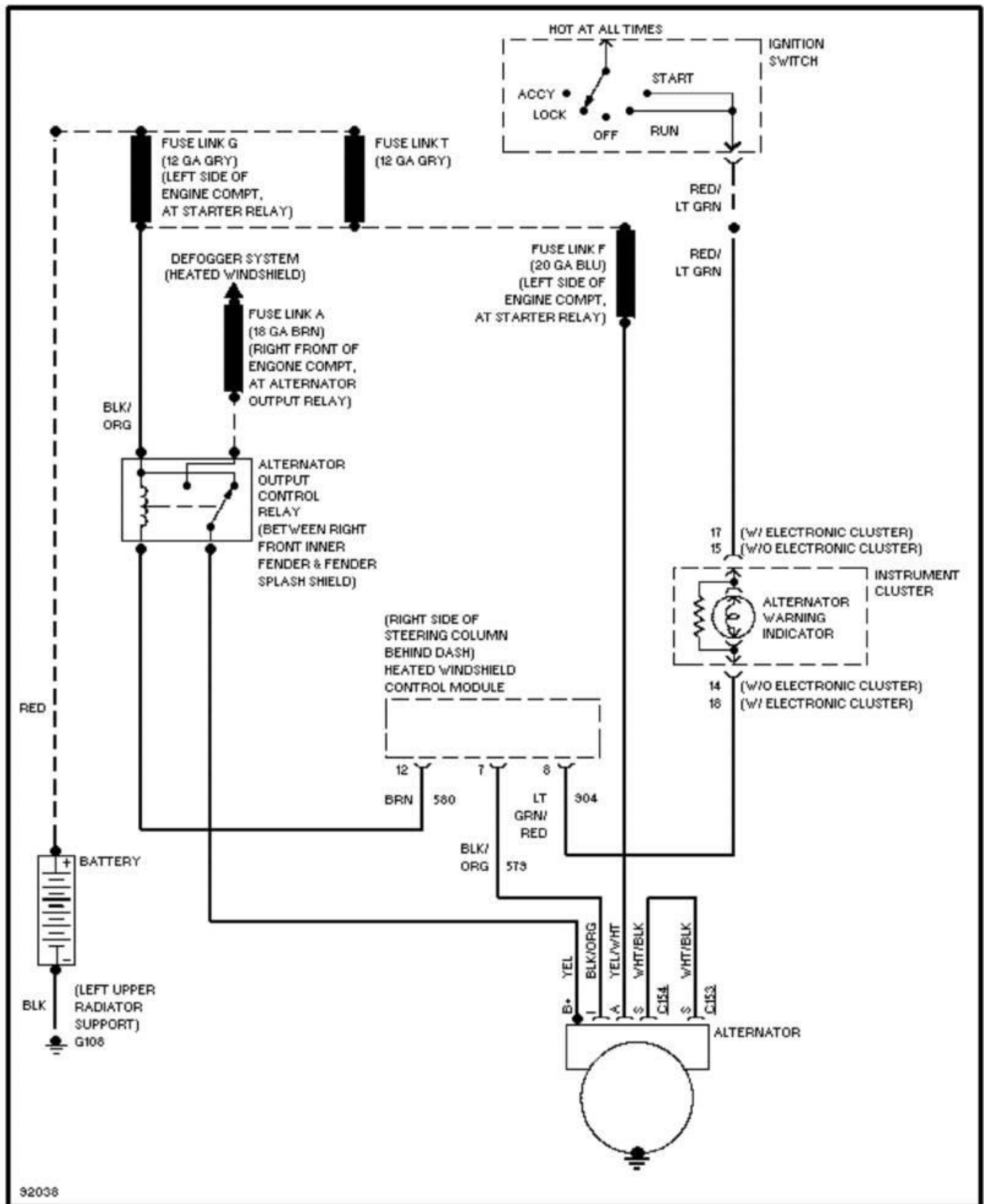

1991 System Wiring Diagrams
Ford - Taurus

PAVLIN

Fig. 18: Charging Circuit, W/O Heated Windshield
1991 Ford Taurus LX

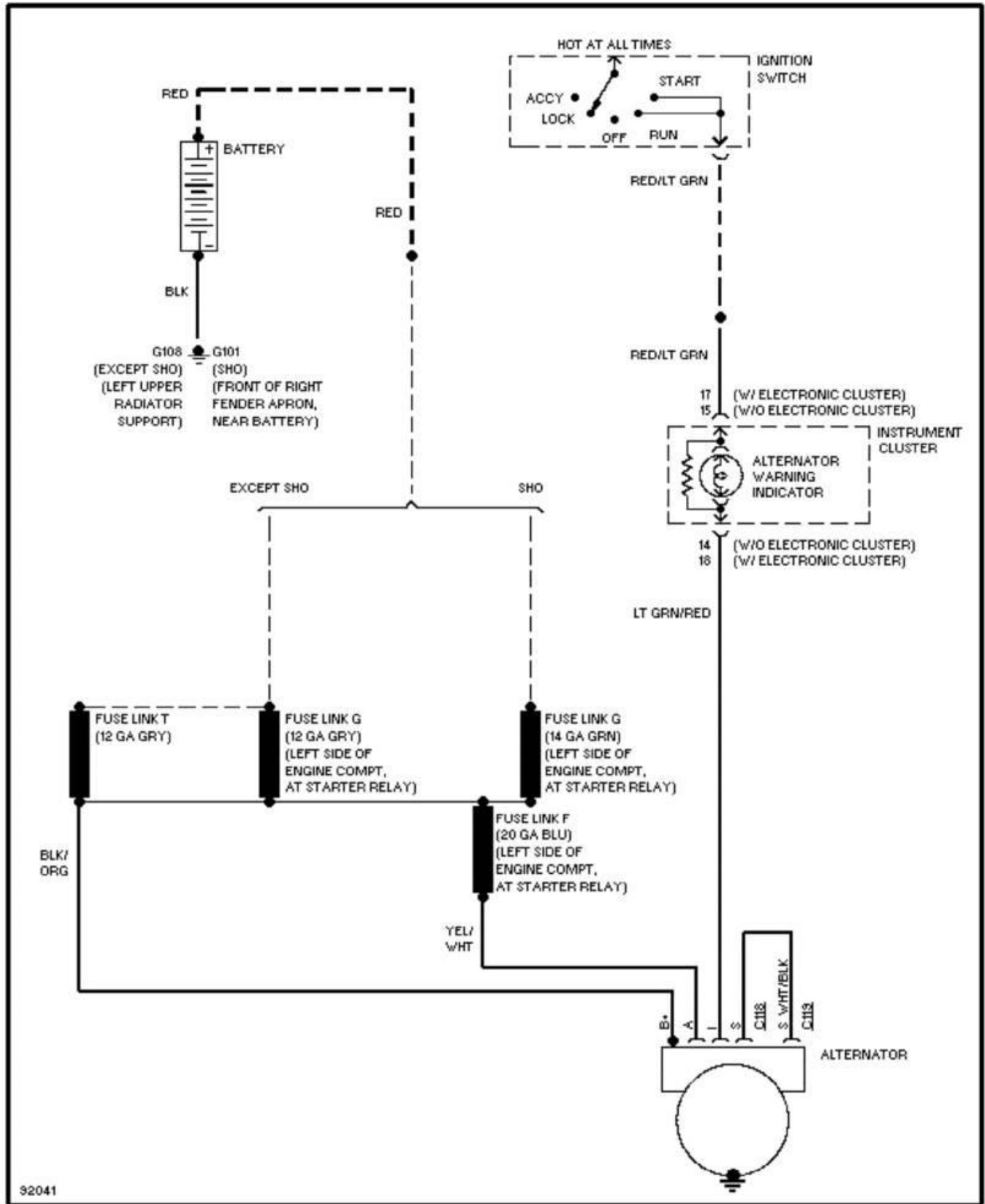

32041

**1991 System Wiring Diagrams
Ford - Taurus**

PAVLIN

Fig. 19: Starting Circuit
1991 Ford Taurus LX

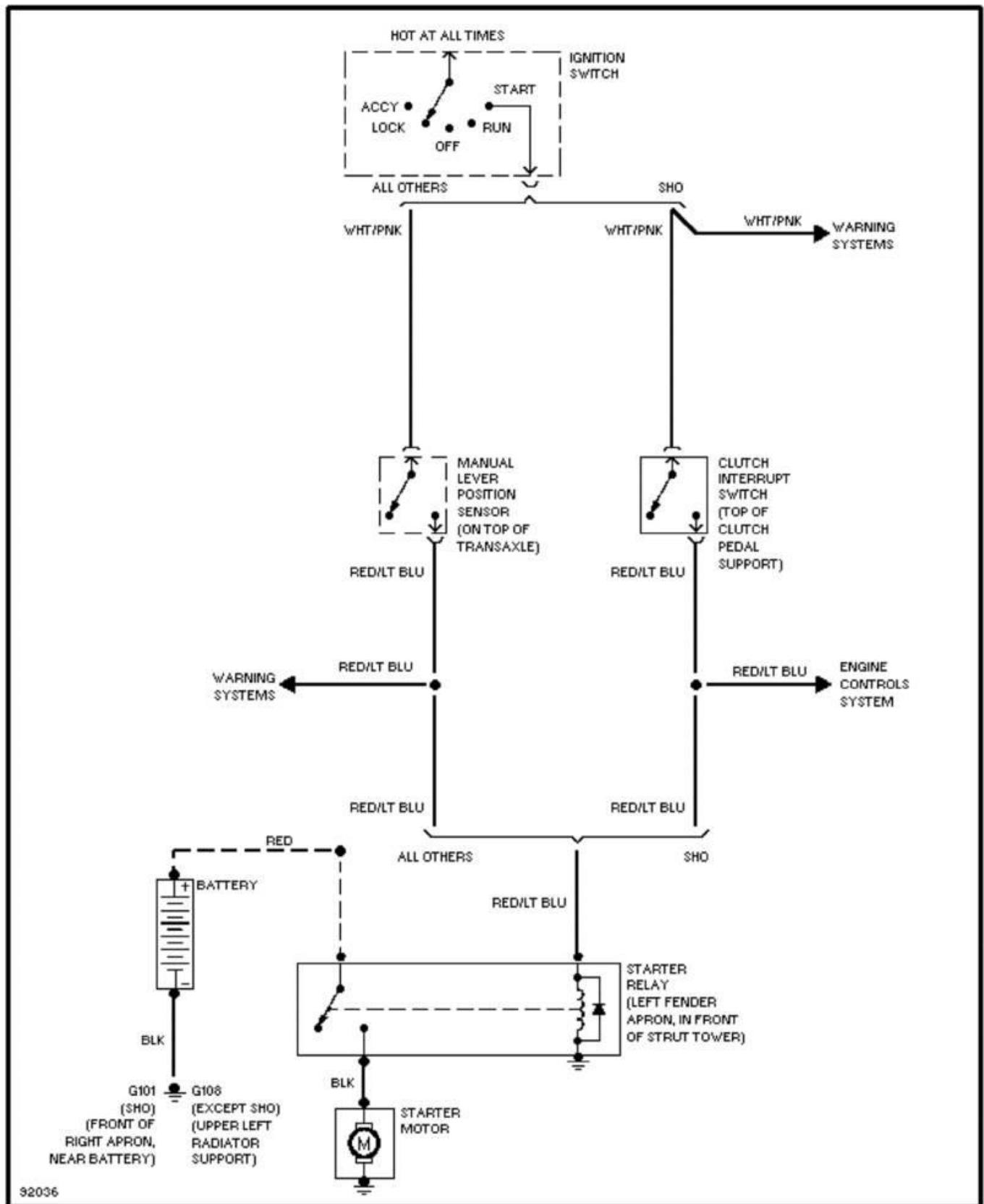

1991 System Wiring Diagrams
Ford - Taurus

PAVLIN

Fig. 20: Trunk Release Circuit
1991 Ford Taurus LX

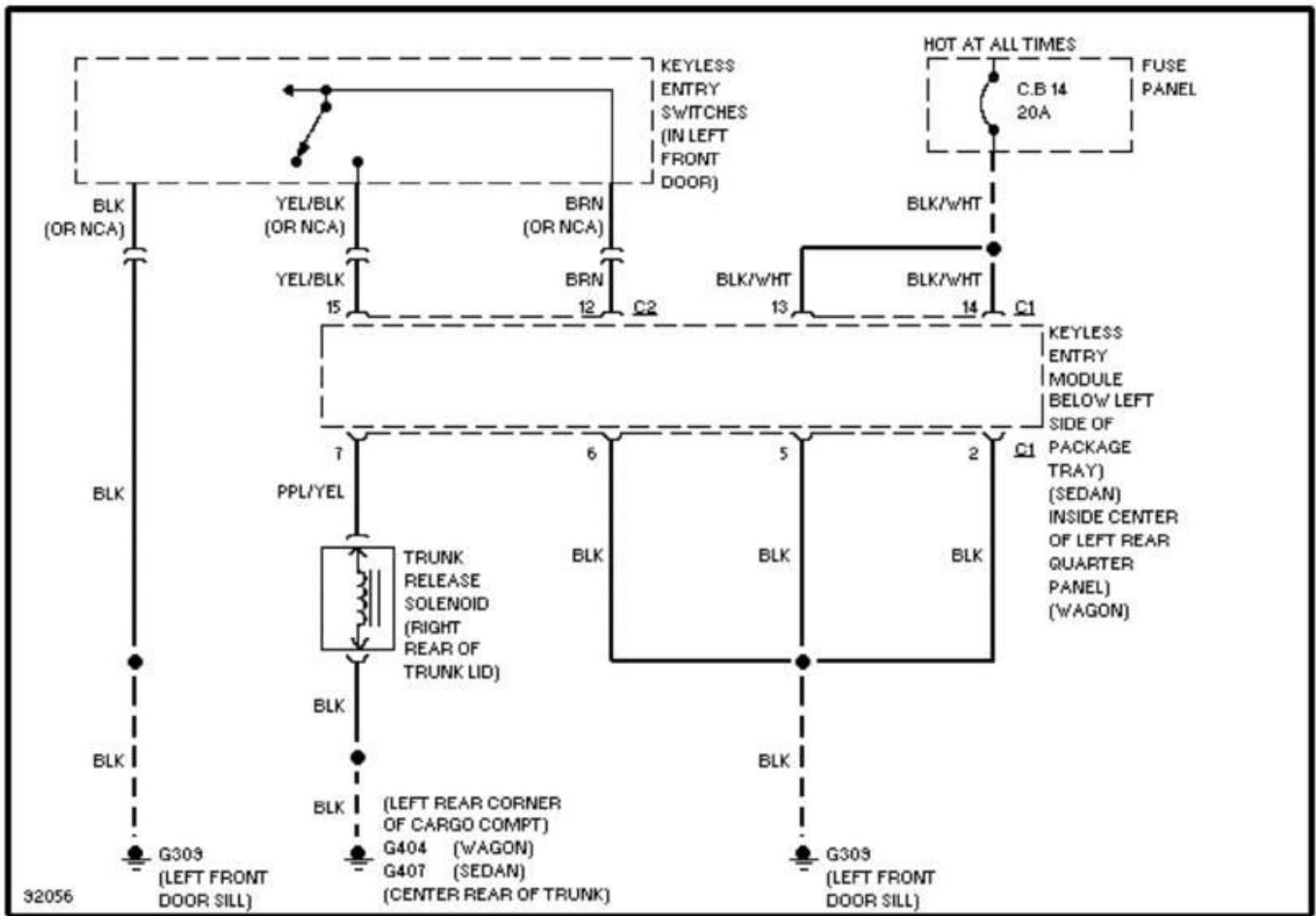

1991 System Wiring Diagrams
Ford - Taurus

PAVLIN

Fig. 21: Interval Wiper/Washer Circuit
1991 Ford Taurus LX

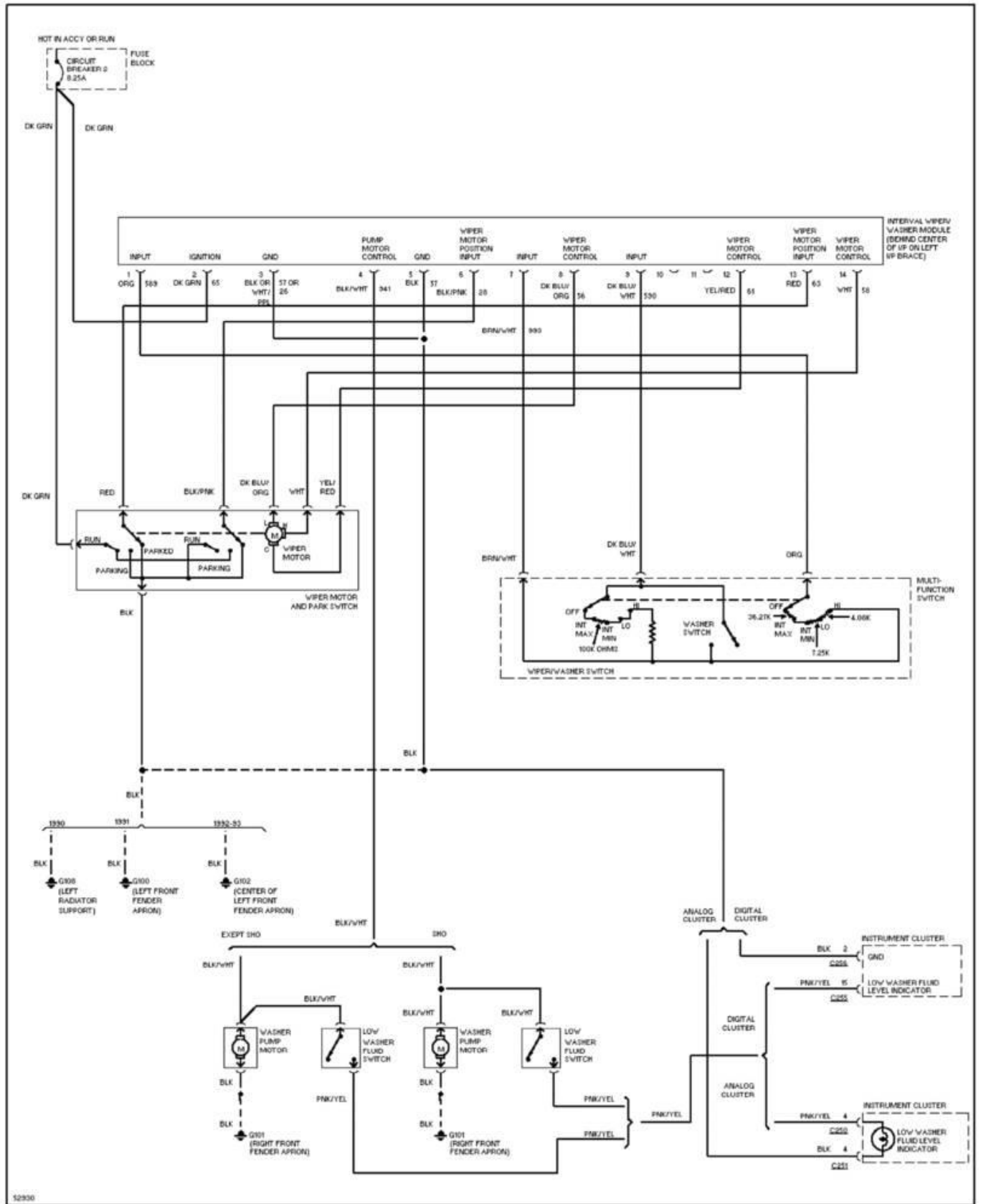

1991 System Wiring Diagrams
Ford - Taurus

PAVLIN

Fig. 22: Rear Wiper/Washer Circuit
1991 Ford Taurus LX

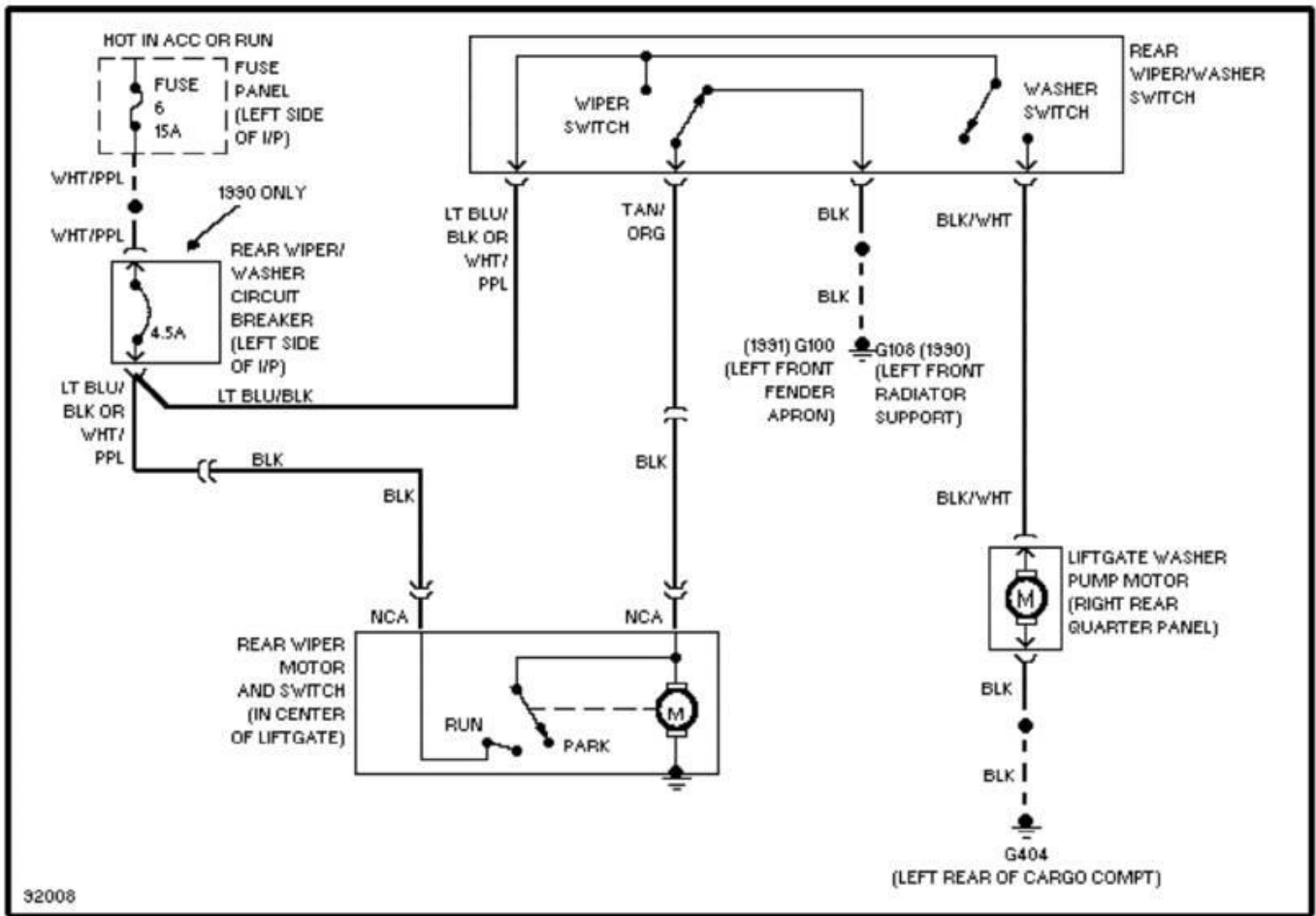

WIRING DIAGRAMS

1991 Wiring Diagrams Ford Motor Co.

PAVLIN

Fig. 1: Headlights & Washer/Wiper, VAPS (Grid 1-3)
1991 Ford Taurus LX

COMPONENT LOCATOR:

A/C CLUTCH CYCLING PRES SW	C 38
A/C COMP CLUTCH (2.5L)	B 9
A/C COMP CLUTCH (3.0L EFI)	A 14
A/C COMP CLUTCH (3.0L SHO)	B 22
A/C COMP CLUTCH (3.8L)	D 21
A/C HEATER FUNCTION SELECT SW	C 37
AIR BAG DIAG MODULE	D-E 32-35
ALTERNATOR	A 7, C 5, D 8
ALTERNATOR OUTPUT CONTROL RELAY	A 7, C 7, E 7
ANTI-LOCK BRAKE SYSTEM	D 8-7
AUTOLAMP DUAL COIL RELAY	A-D 30-26
AUTOLAMP SYSTEM	D-E 44-47
BACK-UP LT SW	D 56-57
BAP SENSOR (3.0L SHO)	A 20-21
BATTERY	A 5, C 5, D 8
BLOWER MOTOR	A 38, C 38, E 38
CKG LTR ASSEMBLY	C 44
CLUTCH	C 47
CLUTCH INTERRUPT SW	B 31
CLUTCH SW (3.0L SHO)	A 9
COOLING FAN (2.5L)	A 13
COOLING FAN (3.0L SHO)	C 22
COOLING FAN (3.8L)	C 20
COURTESY LTS	A-D 44-47
CRUISE CONTROL SERVO	D-E 23
CRUISE CONTROL SW	E 22, E 23
26-INCH CLUM LT	D 23, D 43
D/S MODULE	A 46
DOME LT	D 16
DOME/MAP LT	B 47
DOOR AJAR SWS	A 47
DUAL BRAKE WARNING SW	C 48
EATC CONTROL ASSEMBLY	E 30
EEC (2.5L)	B 9
EEC (3.0L EFI)	B-E 12
EEC (3.0L SHO)	A 16-19
ELECTRONIC FLASHER	A-D 24
ENGINE COMPT LT	C 2
ENGINE SENSORS (3.0L SHO)	C 43
FOG LT RELAY	A 20-21
FOG LT SW	C-D 3
FOG LTS IN-LINE FUSE	E 43
FUEL PUMP	D 3
FUEL LINKS	A 9, A 12, C 21, D 21
FUSE BLOCK	A-E 47
GLOVE BOX LT	D 39
HEATED WIPER CONTROL MOD	A 45
HEATER FUNCTION SELECT SW	D 38
HEGO SENSOR (2.5L)	B 9
HEGO SENSOR (3.0L EFI)	E 14
HEGO SENSORS (3.0L SHO)	E 18
HEGO SENSORS (3.8L)	E 25-26
HIGH LEVEL STOP LTS	D 57
HORN SW (SHO)	D 41
HORN SWS (EX SHO)	C 22
IGNITION COIL (3.5L)	B 11
IGNITION COIL (3.0L EFI)	B 15
IGNITION COIL (3.0L SHO)	D 18
IGNITION SW	E 27
ILLUM ENTRY TIMER	A-C 28
IDENTA SW	A 8, A 12, C 22, D 22
INST PANEL DIMMER RHEOSTAT	D 47
INTEGRATED CONTROL MODULE CCM	B 11, B 15, A 23, E 20
INTERVAL WIPER/WASHER MOD	E 40
KEYLESS ENTRY SYSTEM	A-C 53-55
KNOCK SENSOR (3.0L SHO)	A 70
LOG DIMMING RELAY	B 44
LEFT FRONT DOOR COURTESY LTS	C 44
LFTGATE MERCURY SW	B 44
LOCK CYLINDER ILLUM	C 45-46
LOW OIL LEVEL RELAY	B 51
LT SENSOR AMPLIFIER	E 45
LTS OUT WARNING MOD	A 43
LUGGAGE COMPT LT	A 58
LUMBAR SEATS	E 53
MAIN LT SW	E 44
MANUAL POSITION SENSOR (MPS)	B 31
MOONROOF	B-C 66
MULTI-FUNCTION SW	A-D 40
PARKING BRAKE SW	B 48
POLICE ACRYL RELAY	D 58
POWER ANTENNA	D 58
POWER DOOR LOCKS	A 52-55, A 57-59
POWER SEATS	D-E 84-95
POWER WINDOW SAFETY RELAY	A 50
POWER WINDOWS	B-D 52-53
RADIATOR COOLANT SENSOR	C 51
RADIO (PARTIAL)	E 36
REAR DOOR COURTESY LTS	A-B 44
REAR WINDOW DEFOG CONTROL	E 43
REAR WIPER/WASHER STARTER RELAY	B 4, C 4, E 4
STO CONN (2.5L)	B 10
STO CONN (3.0L EFI)	B 14
STO CONN (3.0L SHO)	E 18-19
STO CONN (3.8L)	A 27
STOP LT SW	C 43
THROTTLE POSITION SENSOR (3.0L SHO)	A 20
VANITY LTS	A 47
VARIABLE ASSIST POWER STEERING (VAPS)	E 3
VEHICLE SPEED SENSOR	A 16, E 22
WARNING CHIME MODULE	E 37-38
WASHER FLUID LEVEL SW	B 3, C 3
WIPER MOTOR	A 3

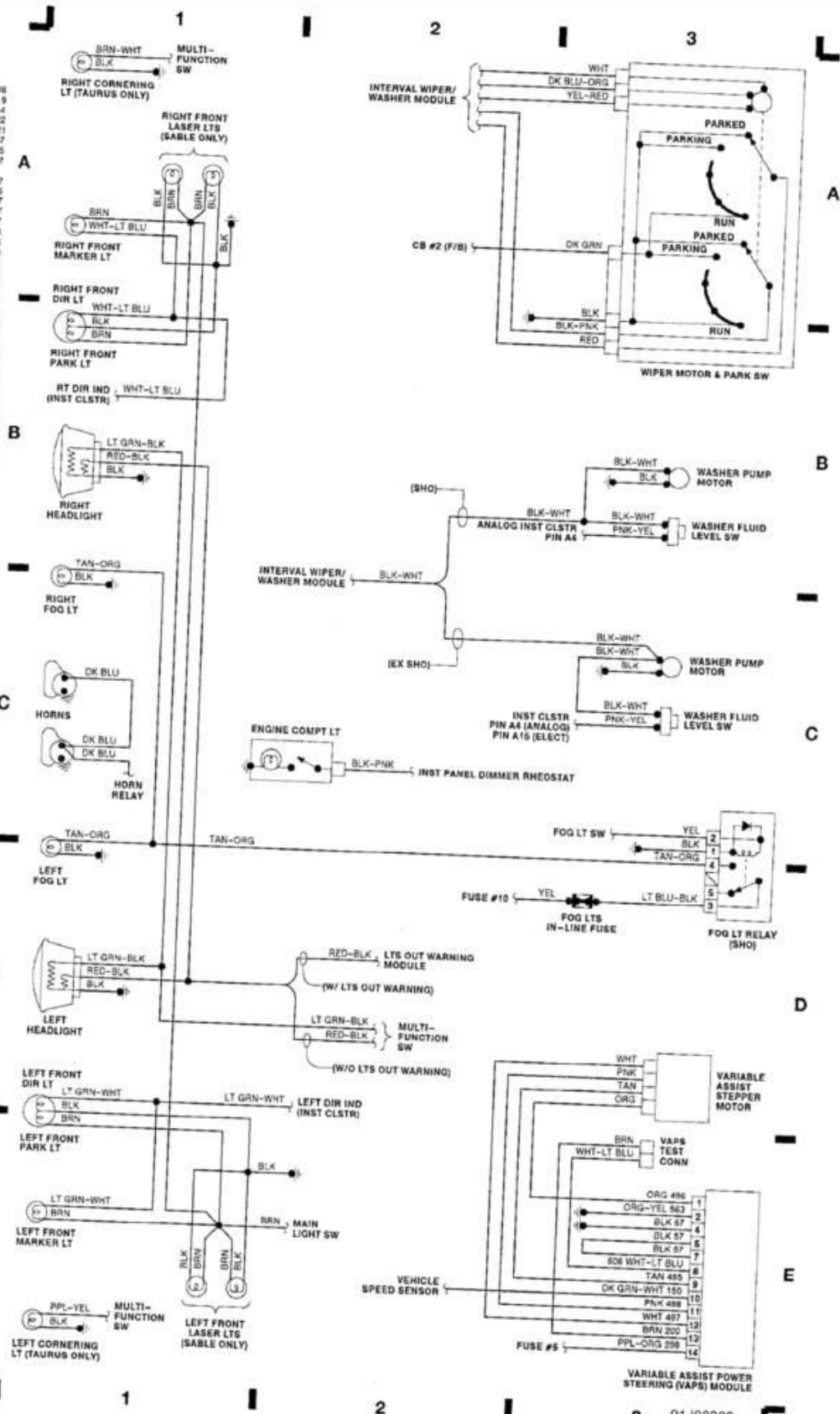

WIRING DIAGRAMS

1991 Wiring Diagrams Ford Motor Co.

PAVLIN

Fig. 2: Engine Compartment (Grid 4-7)
1991 Ford Taurus LX

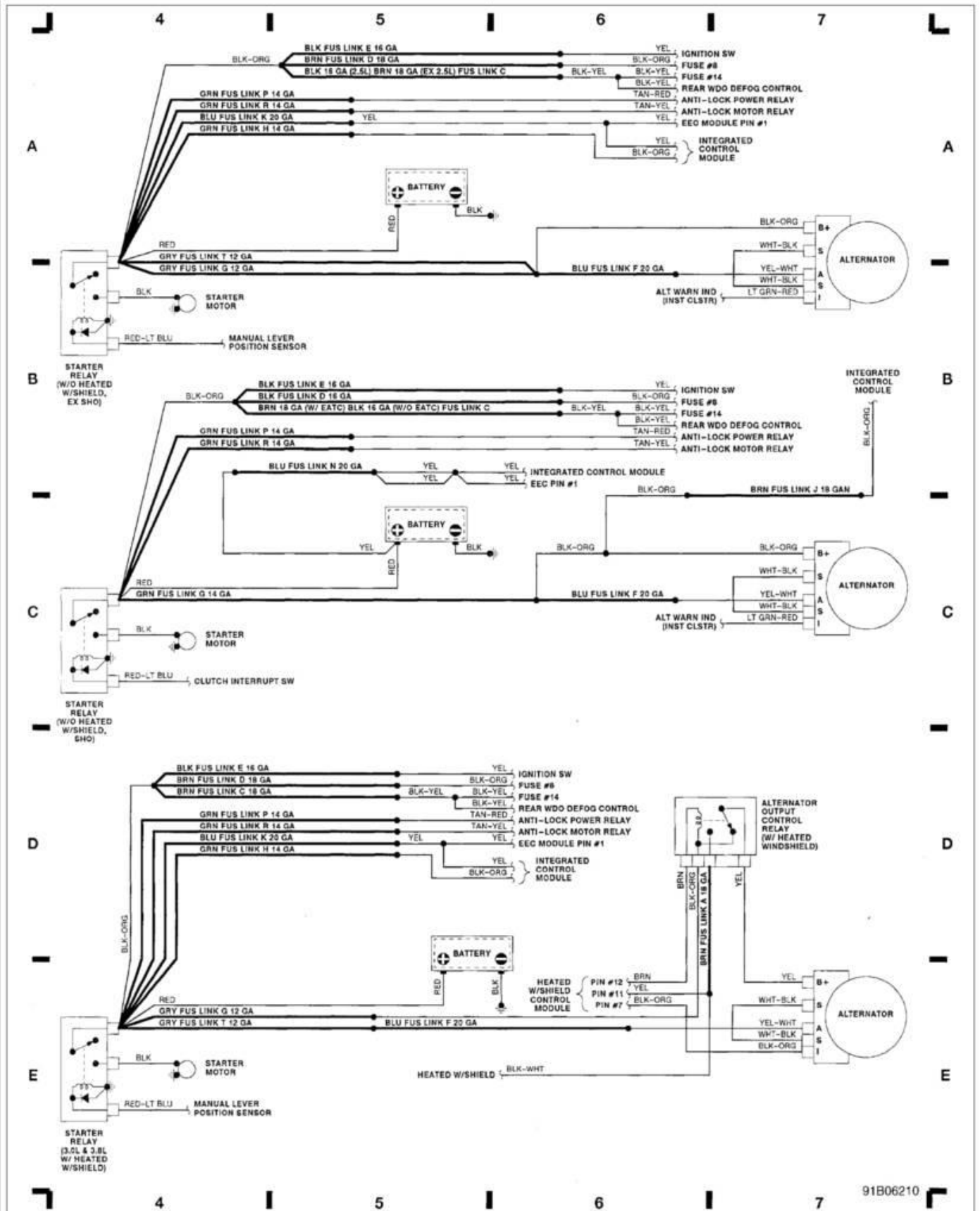

91B06210

WIRING DIAGRAMS

1991 Wiring Diagrams Ford Motor Co.

PAVLIN

Fig. 3: Elect Engine Control (2.5L) (Grid 8-11)
1991 Ford Taurus LX

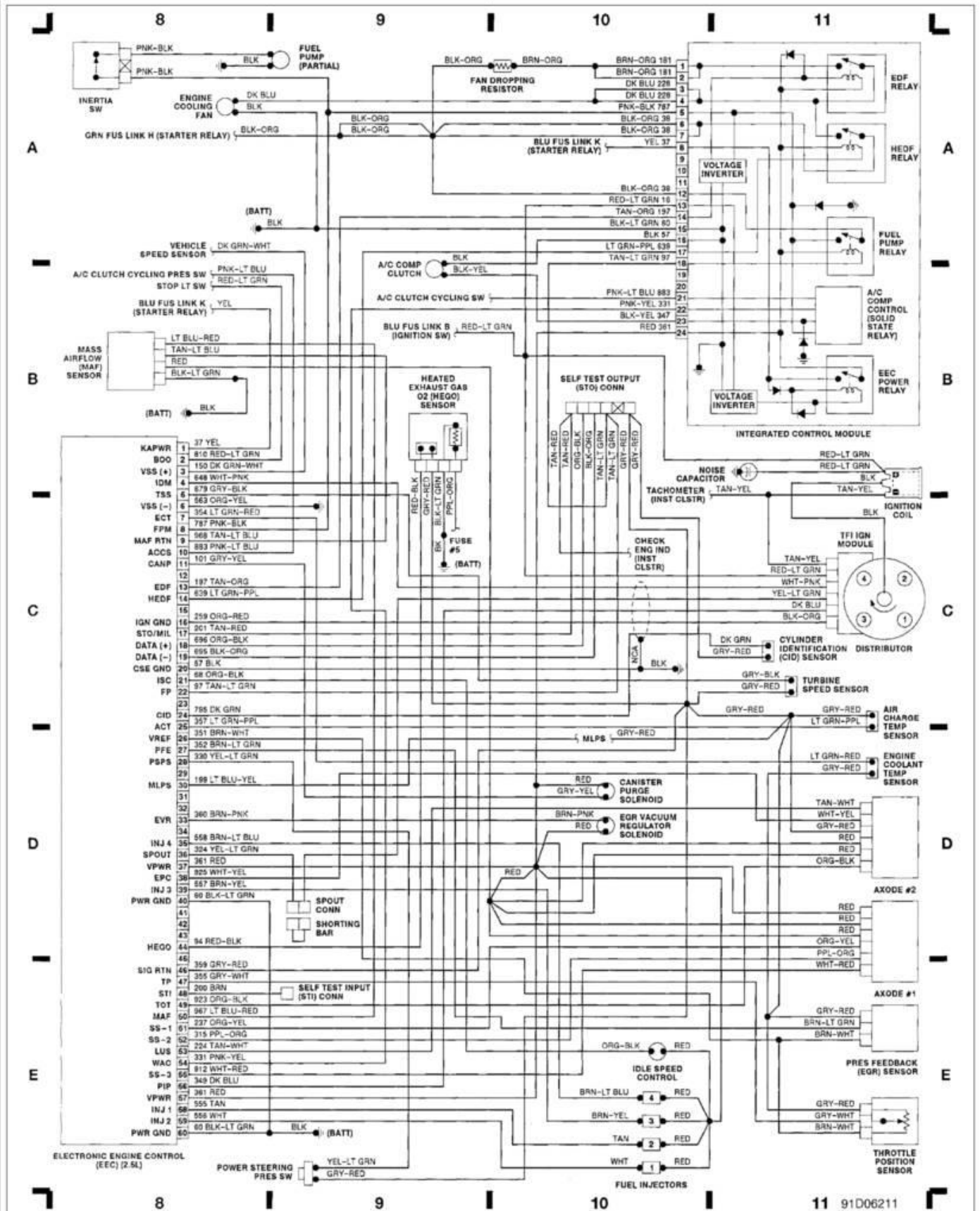

WIRING DIAGRAMS

1991 Wiring Diagrams Ford Motor Co.

PAVLIN

Fig. 4: Elect Engine Control (3.0L EFI) (Grid 12-15)
1991 Ford Taurus LX

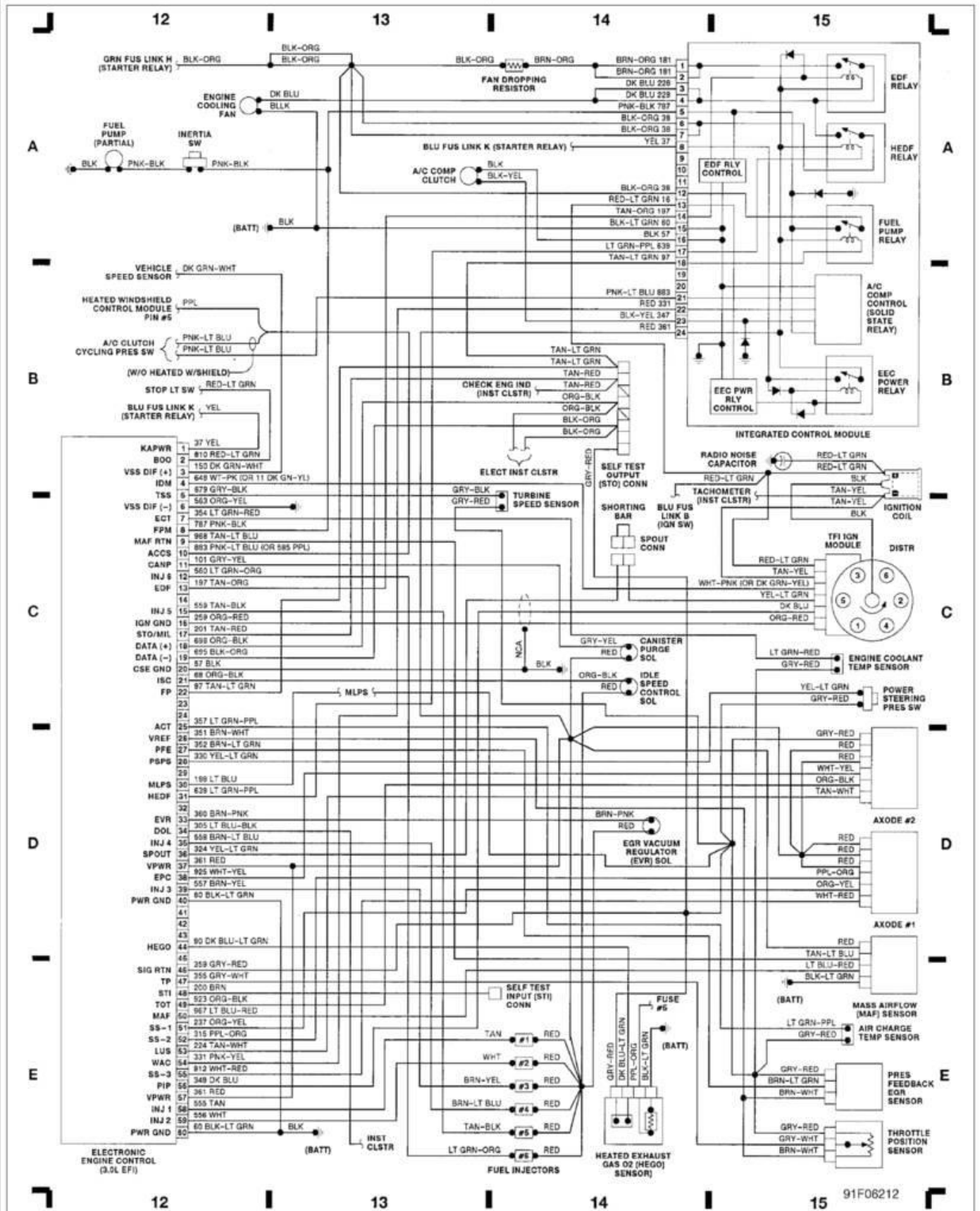

WIRING DIAGRAMS

1991 Wiring Diagrams Ford Motor Co.

PAVLIN

Fig. 5: Elect Engine Control (3.0L SHO) (Grid 16-19)
1991 Ford Taurus LX

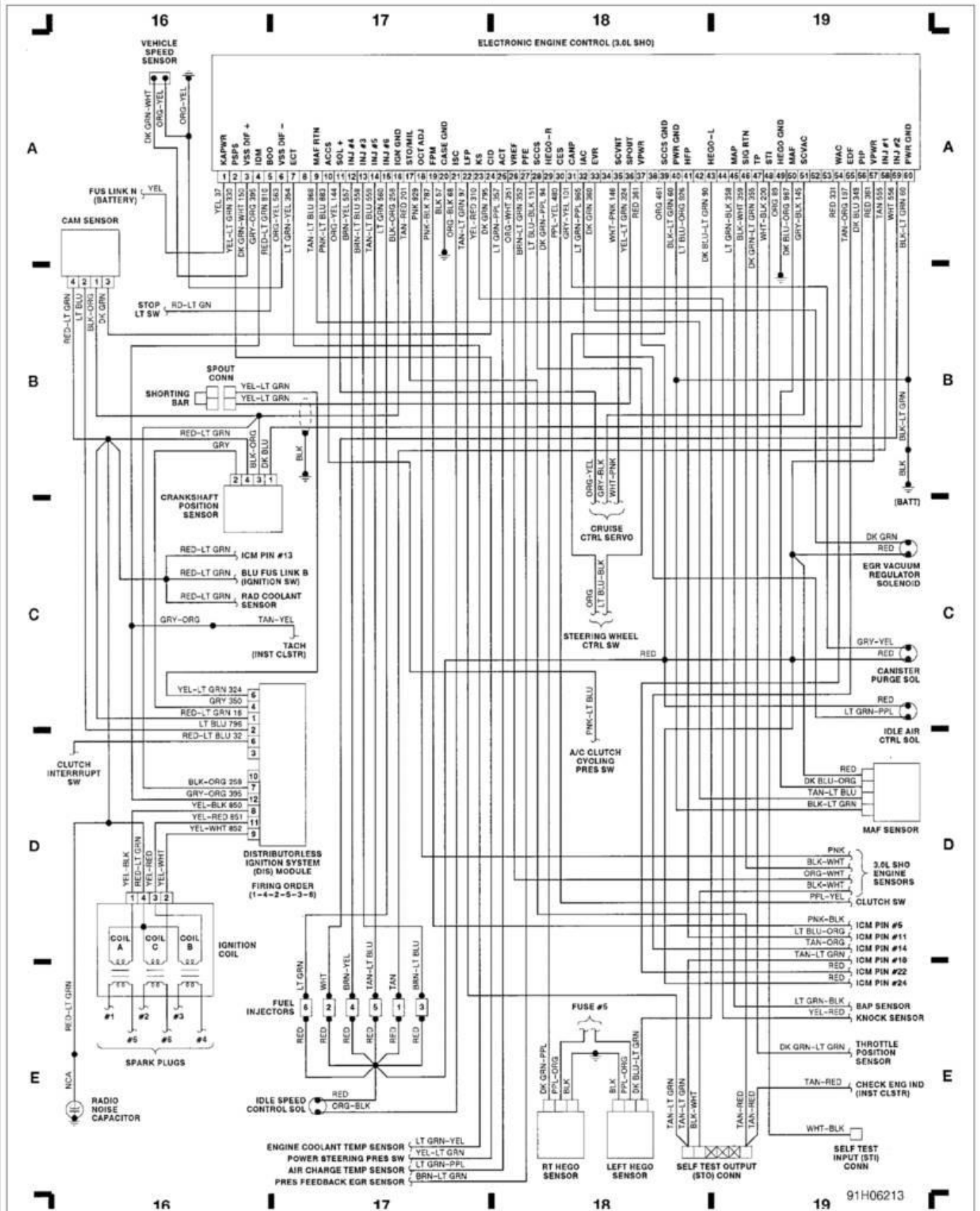

WIRING DIAGRAMS
1991 Wiring Diagrams Ford Motor Co.

PAVLIN

Fig. 6: Cruise Control, ICM (3.0L SHO/3.8L) (Grid 20-23)
1991 Ford Taurus LX

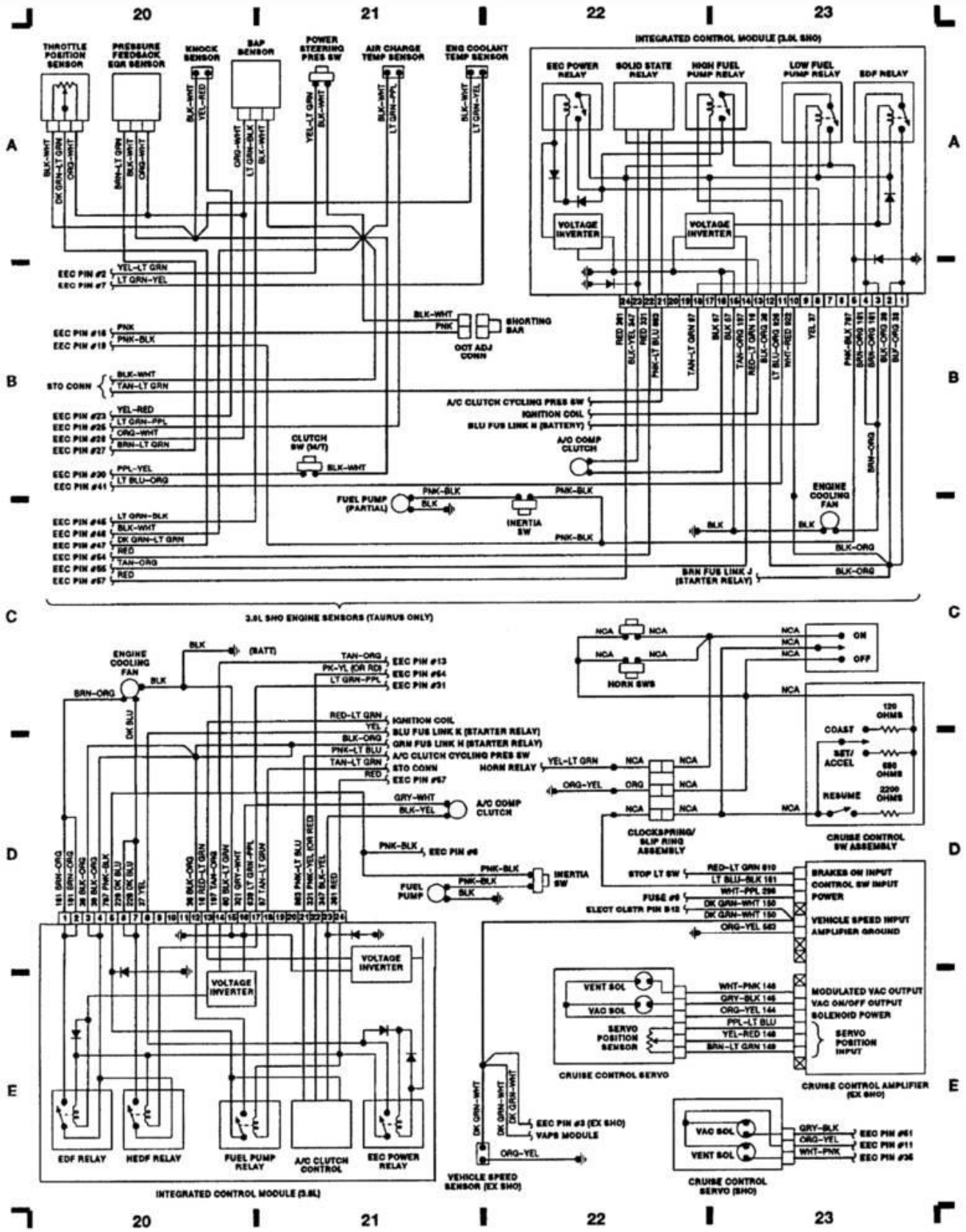

91J06214

WIRING DIAGRAMS

1991 Wiring Diagrams Ford Motor Co.

PAVLIN

Fig. 7: Elect Engine Control (3.8L) (Grid 24-27)
1991 Ford Taurus LX

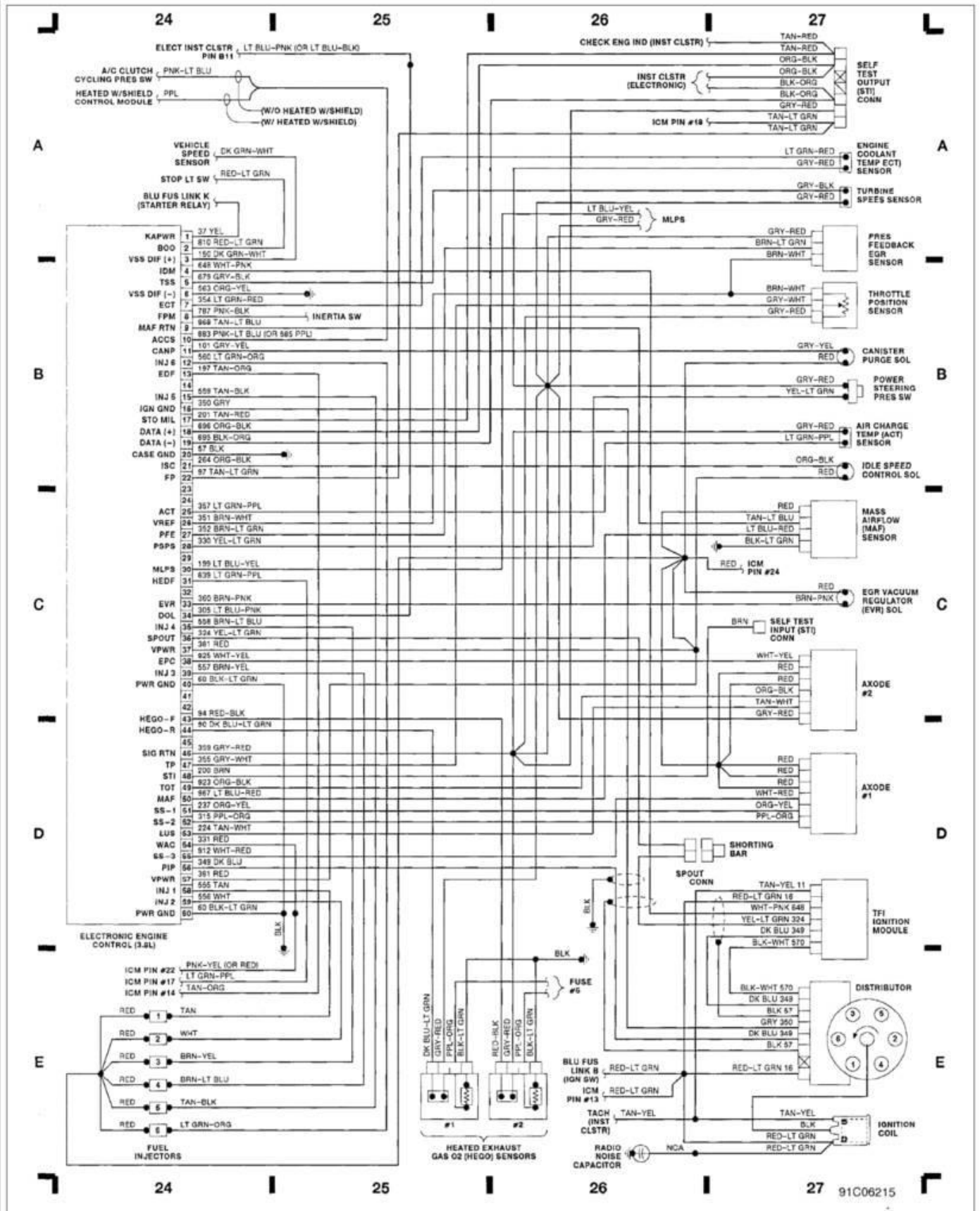

WIRING DIAGRAMS

1991 Wiring Diagrams Ford Motor Co.

PAVLIN

Fig. 8: Fuse Block, Ignition Switch, MLPS (Grid 28-31)
1991 Ford Taurus LX

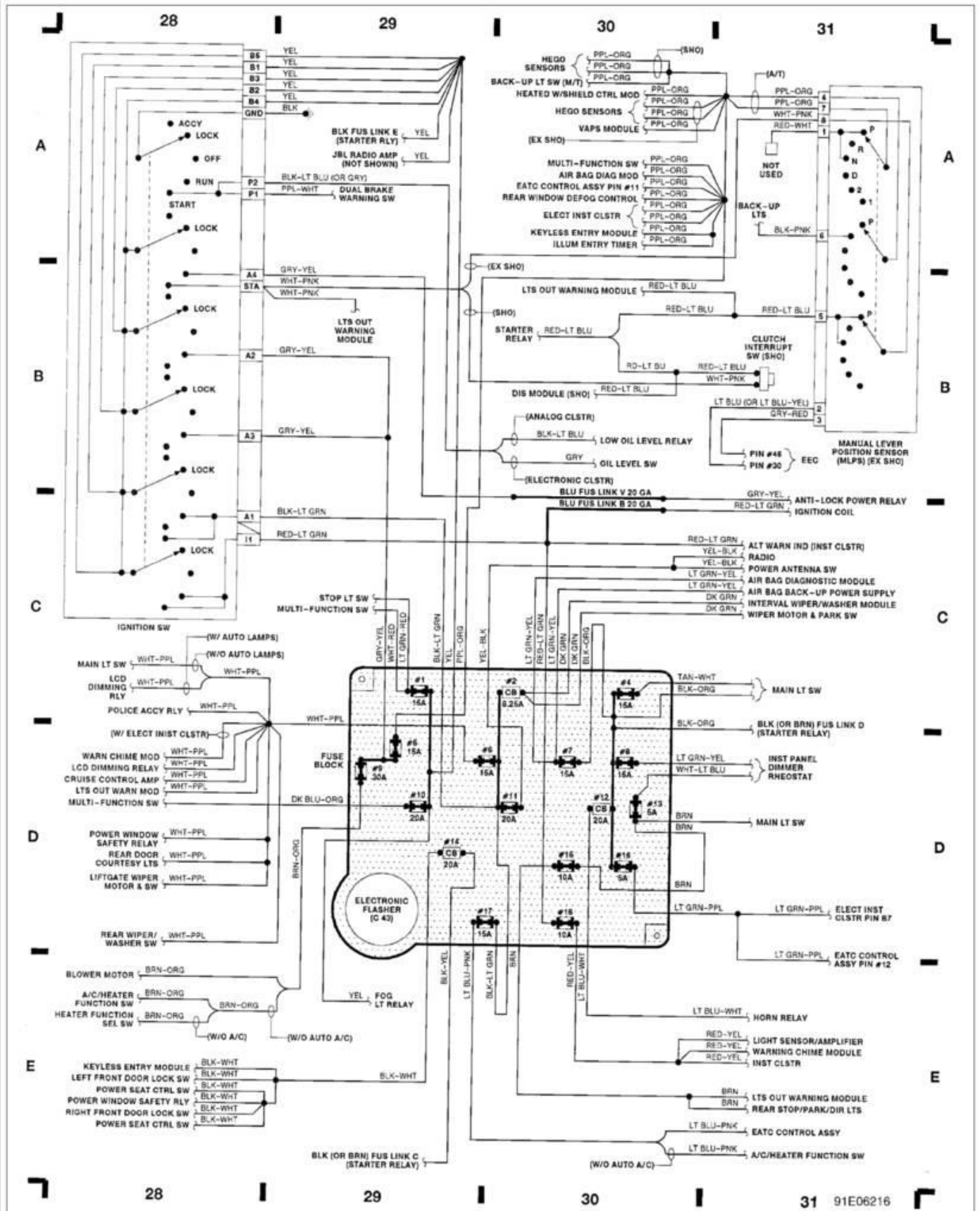

WIRING DIAGRAMS

1991 Wiring Diagrams Ford Motor Co.

PAVLIN

Fig. 9: ABS, Air Bag (Grid 32-35)
1991 Ford Taurus LX

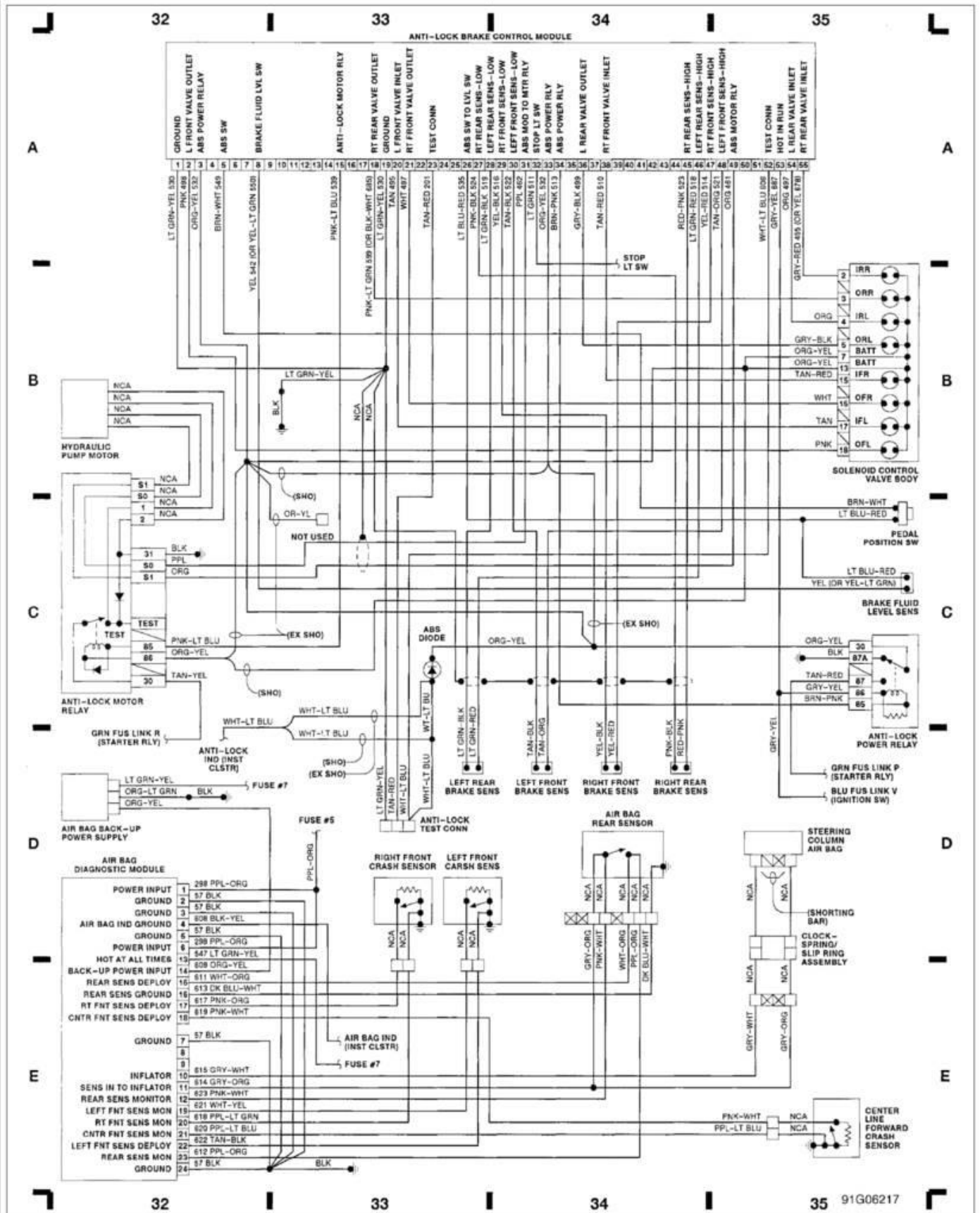

WIRING DIAGRAMS

1991 Wiring Diagrams Ford Motor Co.

PAVLIN

Fig. 11: Multi-Function Sw, Steering Wheel Ctrl Sw (Grid 40-43)
1991 Ford Taurus LX

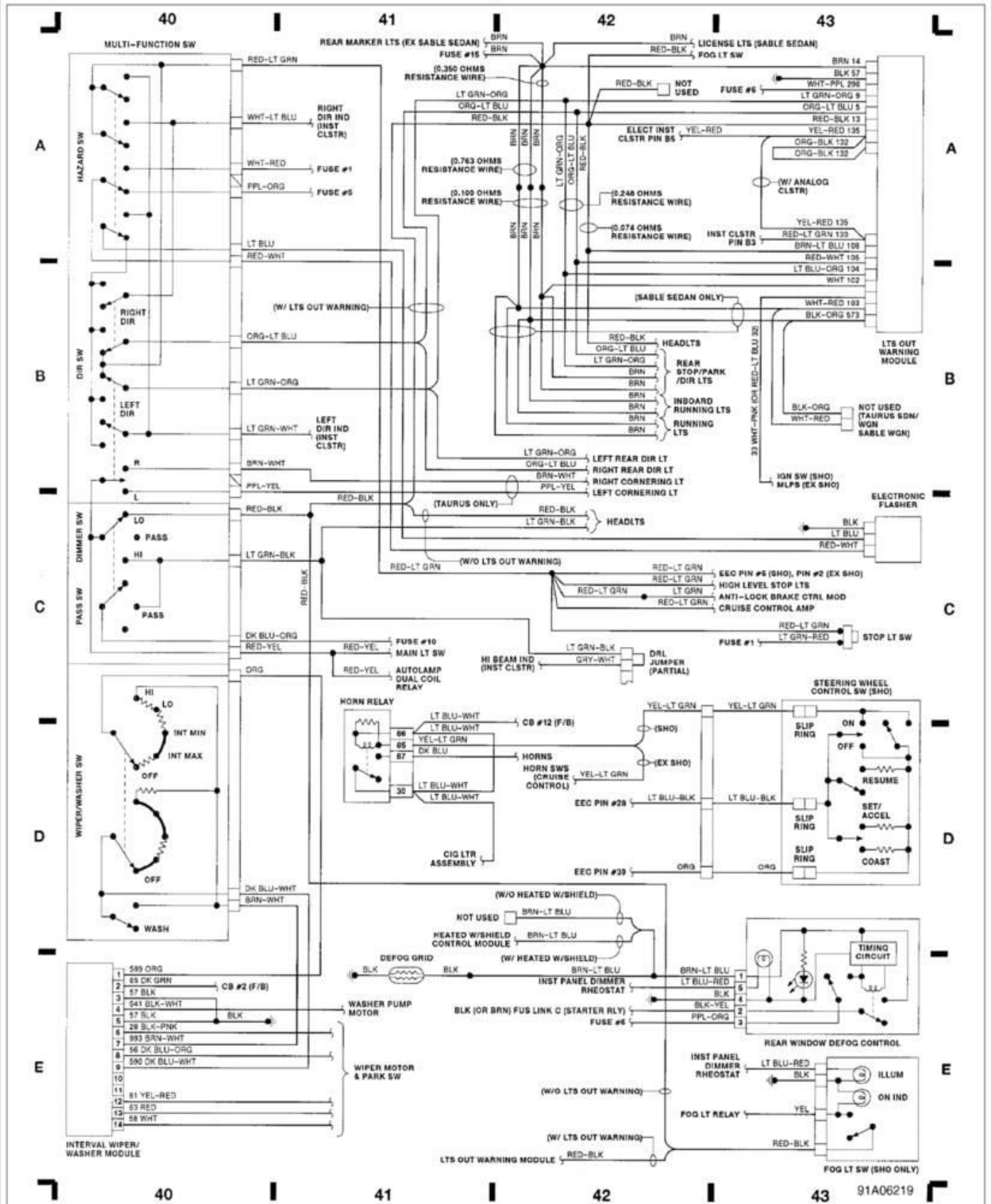

WIRING DIAGRAMS

1991 Wiring Diagrams Ford Motor Co.

PAVLIN

Fig. 10: EATC, A/C/Heater (Grid 36-39)
1991 Ford Taurus LX

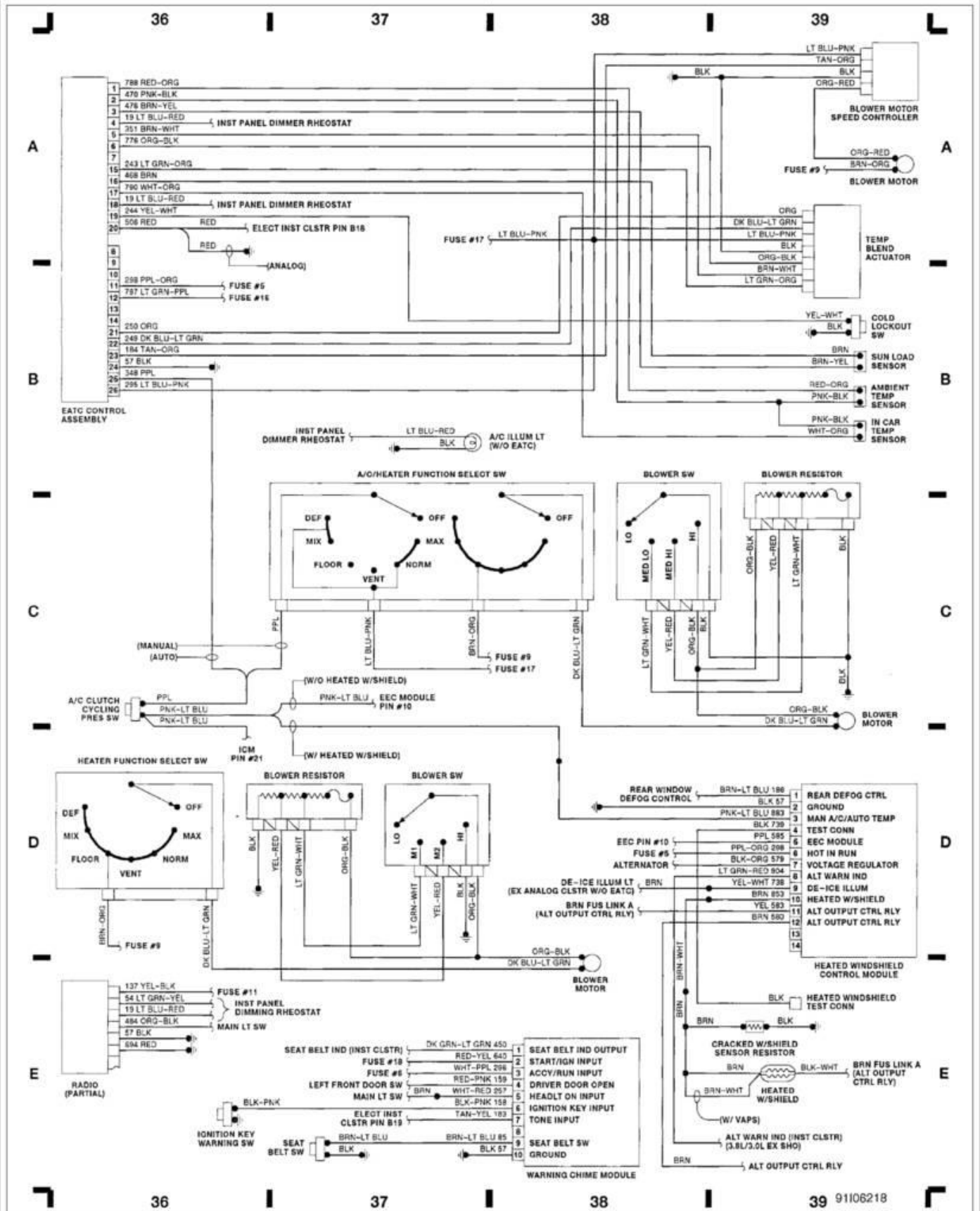

WIRING DIAGRAMS

1991 Wiring Diagrams Ford Motor Co.

PAVLIN

Fig. 13: Instrument Clusters (Grid 48-51)
1991 Ford Taurus LX

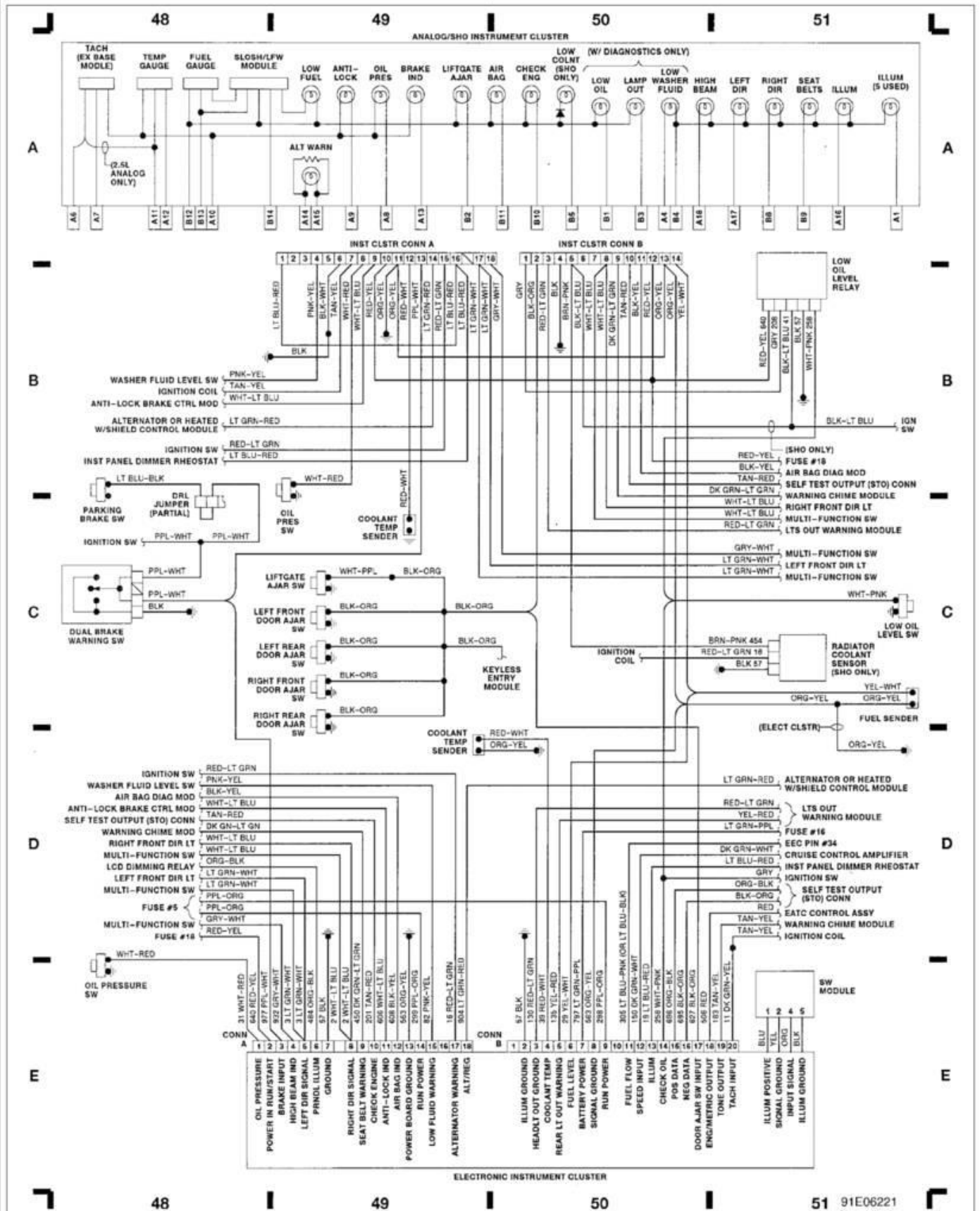

WIRING DIAGRAMS

1991 Wiring Diagrams Ford Motor Co.

PAVLIN

Fig. 14: Keyless Entry, Power Seat/Window (Grid 52-55)
1991 Ford Taurus LX

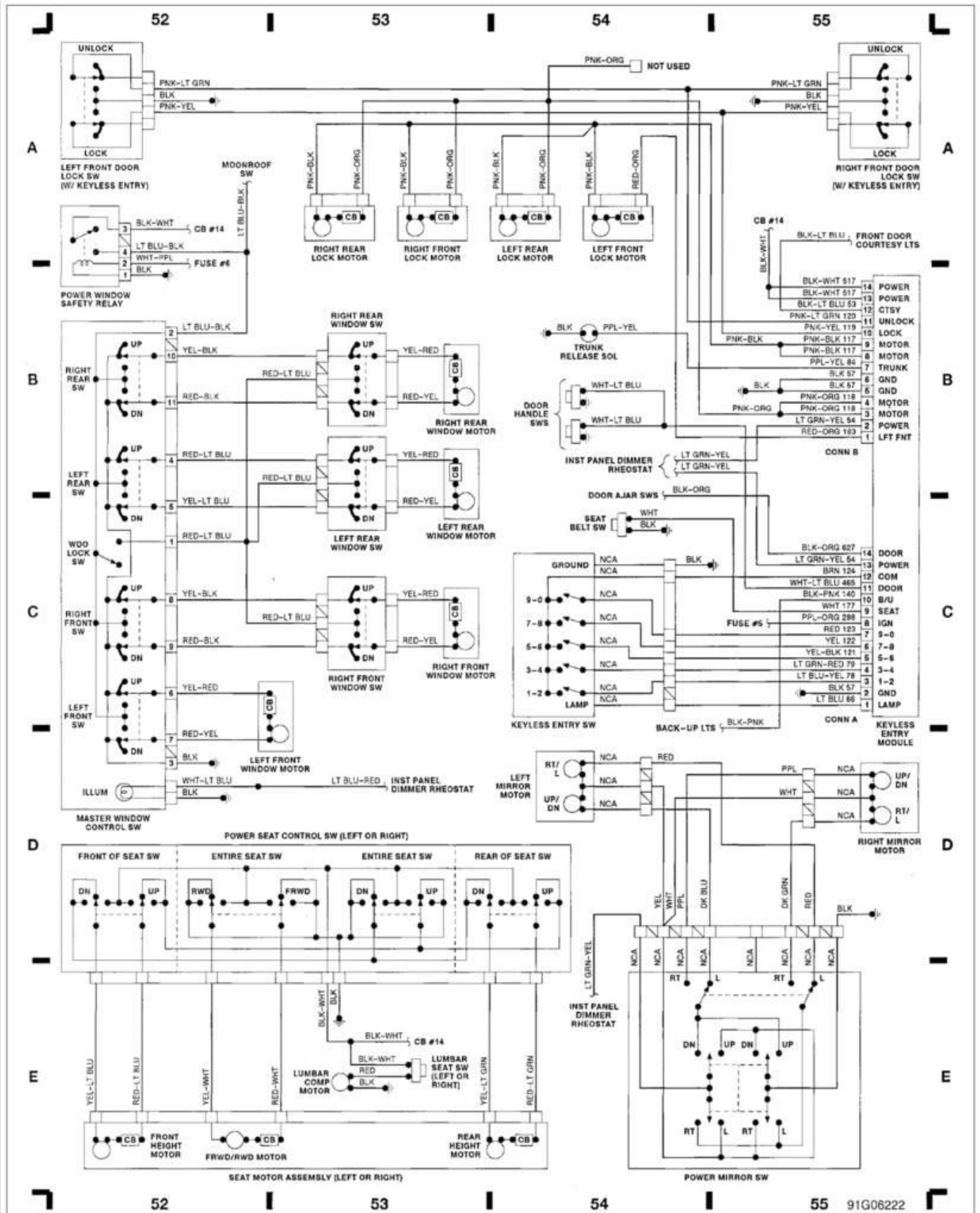

WIRING DIAGRAMS

1991 Wiring Diagrams Ford Motor Co.

PAVLIN

Fig. 15: Power Doors (W/O Keyless), Taillights (Grid 56-59)
1991 Ford Taurus LX

