

1992 System Wiring Diagrams
Ford - Taurus

PAVLIN

Fig. 1: 3.0L SHO, Cooling Fan Circuit
1992 Ford Taurus LX

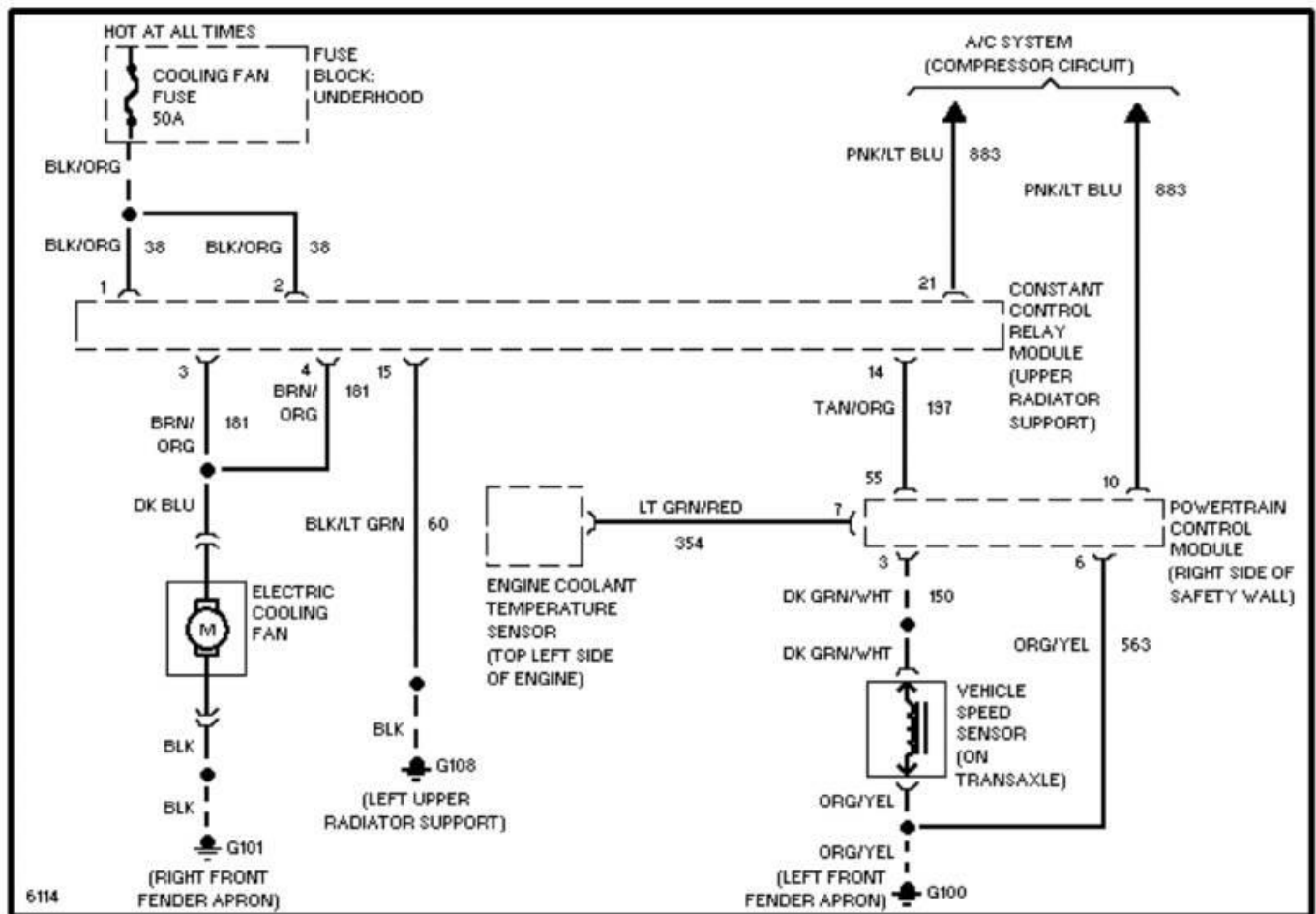

1992 System Wiring Diagrams
Ford - Taurus

PAVLIN

Fig. 2: 3.0L, Cooling Fan Circuit
1992 Ford Taurus LX

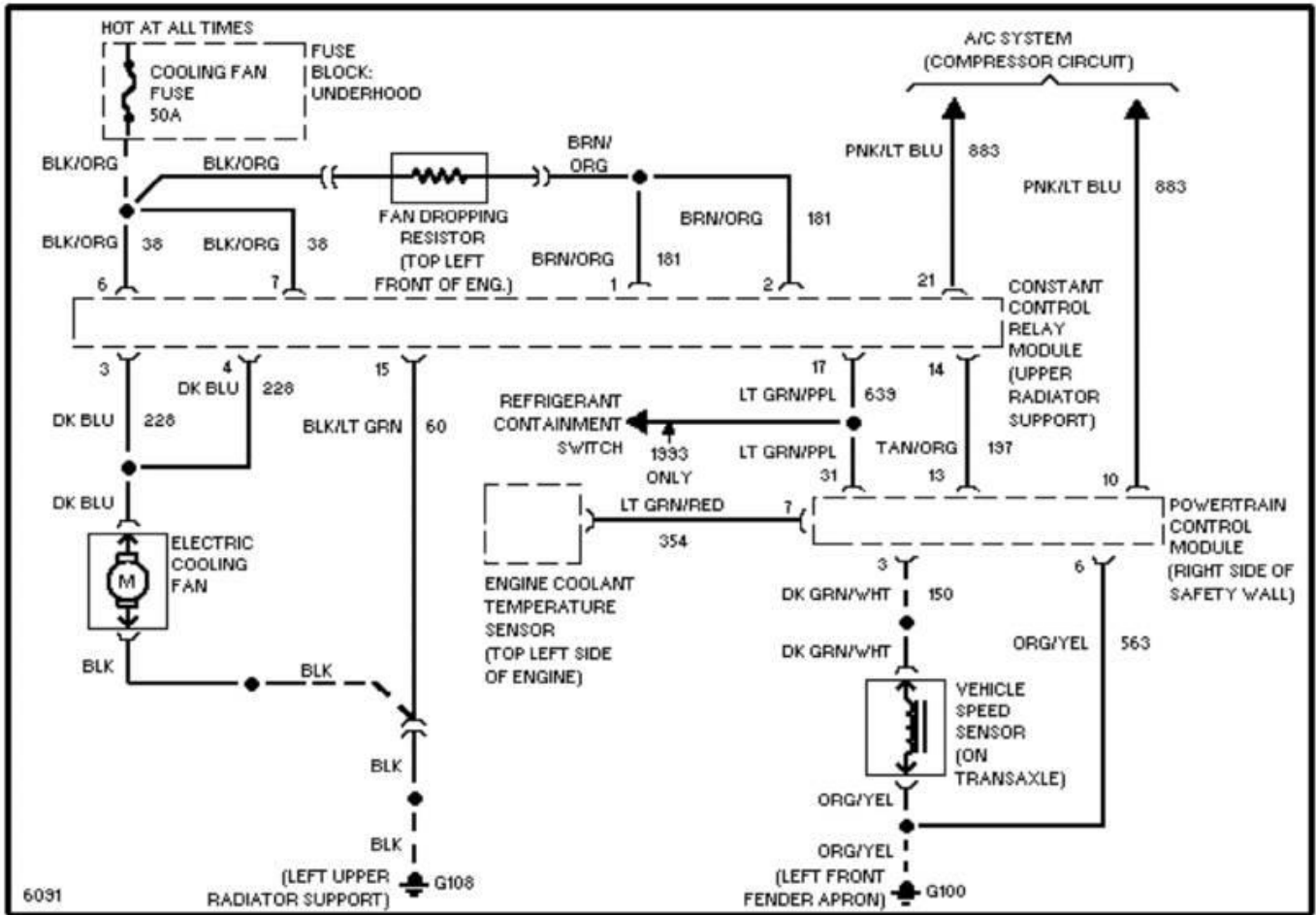

1992 System Wiring Diagrams
Ford - Taurus

PAVLIN

Fig. 3: 3.8L, Cooling Fan Circuit
1992 Ford Taurus LX

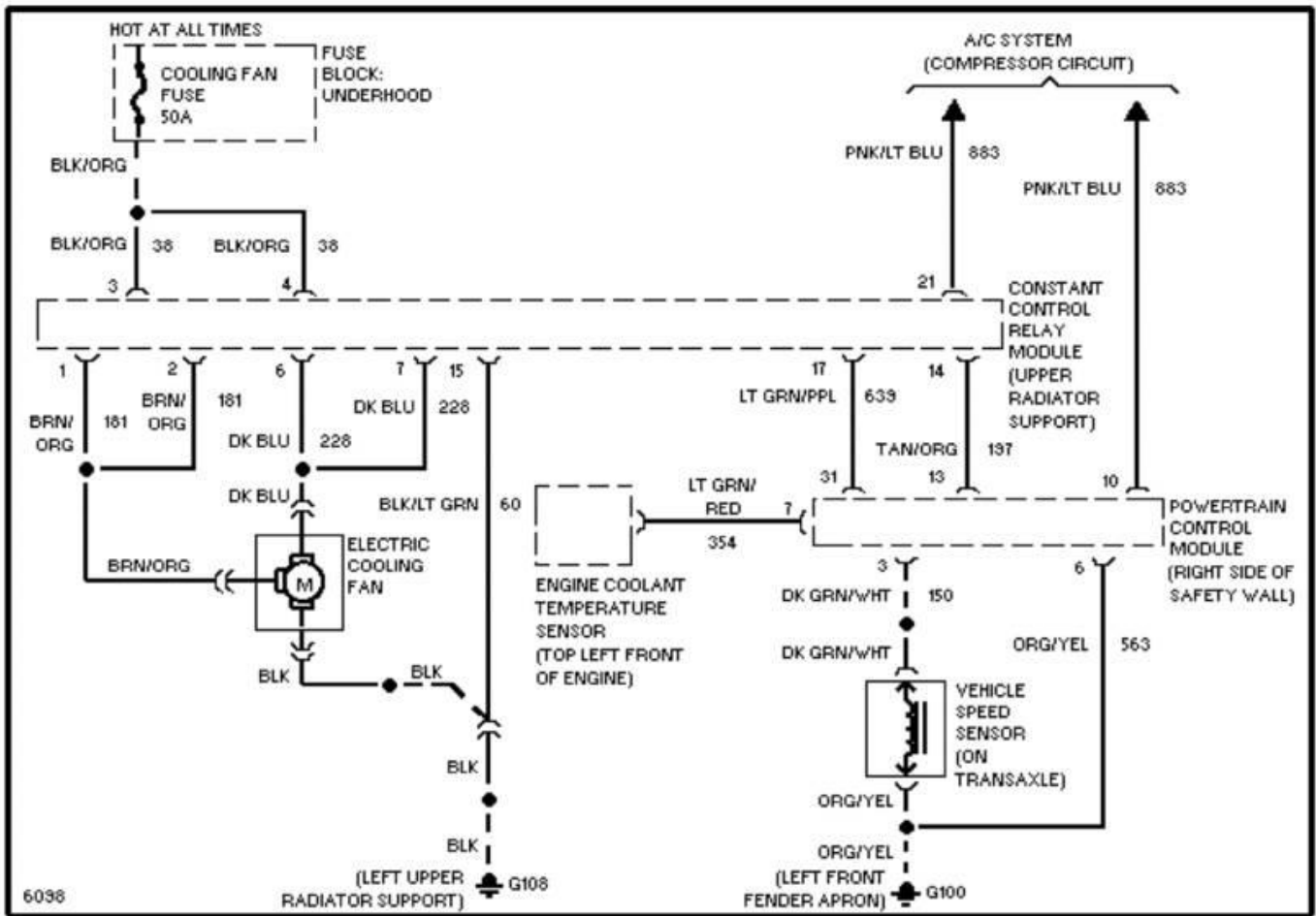

1992 System Wiring Diagrams
Ford - Taurus

PAVLIN

Fig. 4: Defogger Circuit
1992 Ford Taurus LX

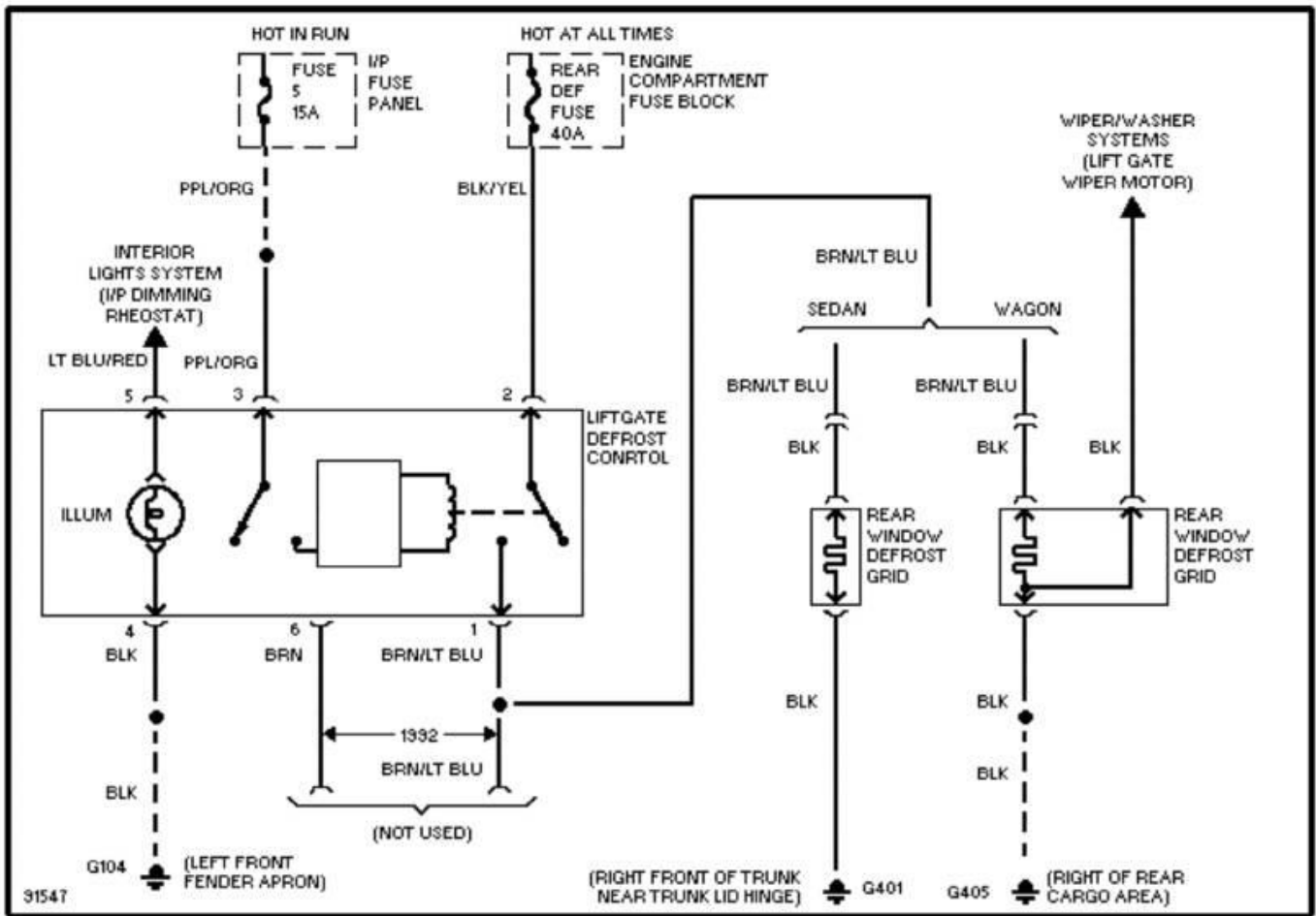

1992 System Wiring Diagrams
Ford - Taurus

PAVLIN

Fig. 5: Horn Circuit
1992 Ford Taurus LX

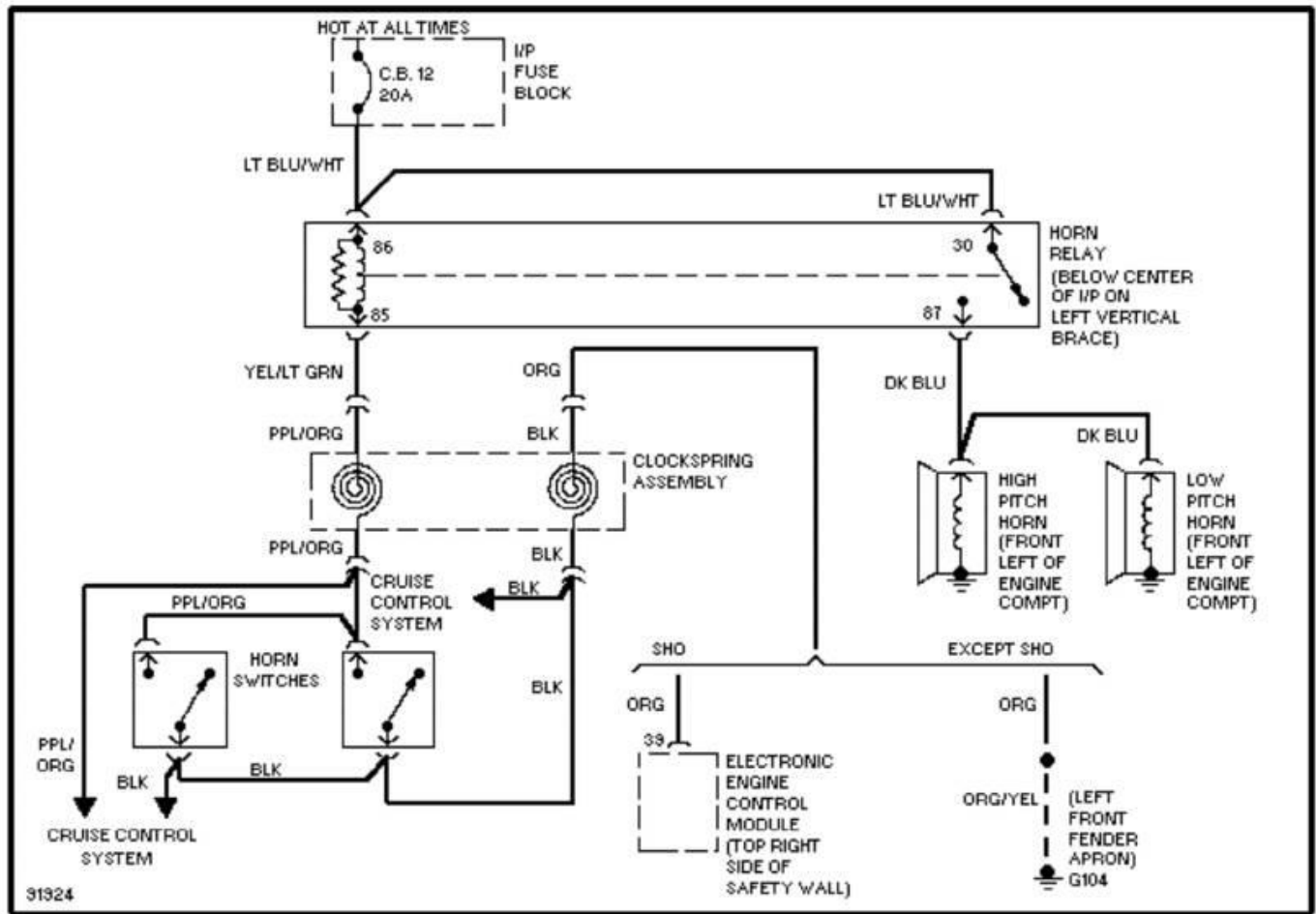

91324

1992 System Wiring Diagrams
Ford - Taurus

PAVLIN

Fig. 6: Power Antenna Circuit
1992 Ford Taurus LX

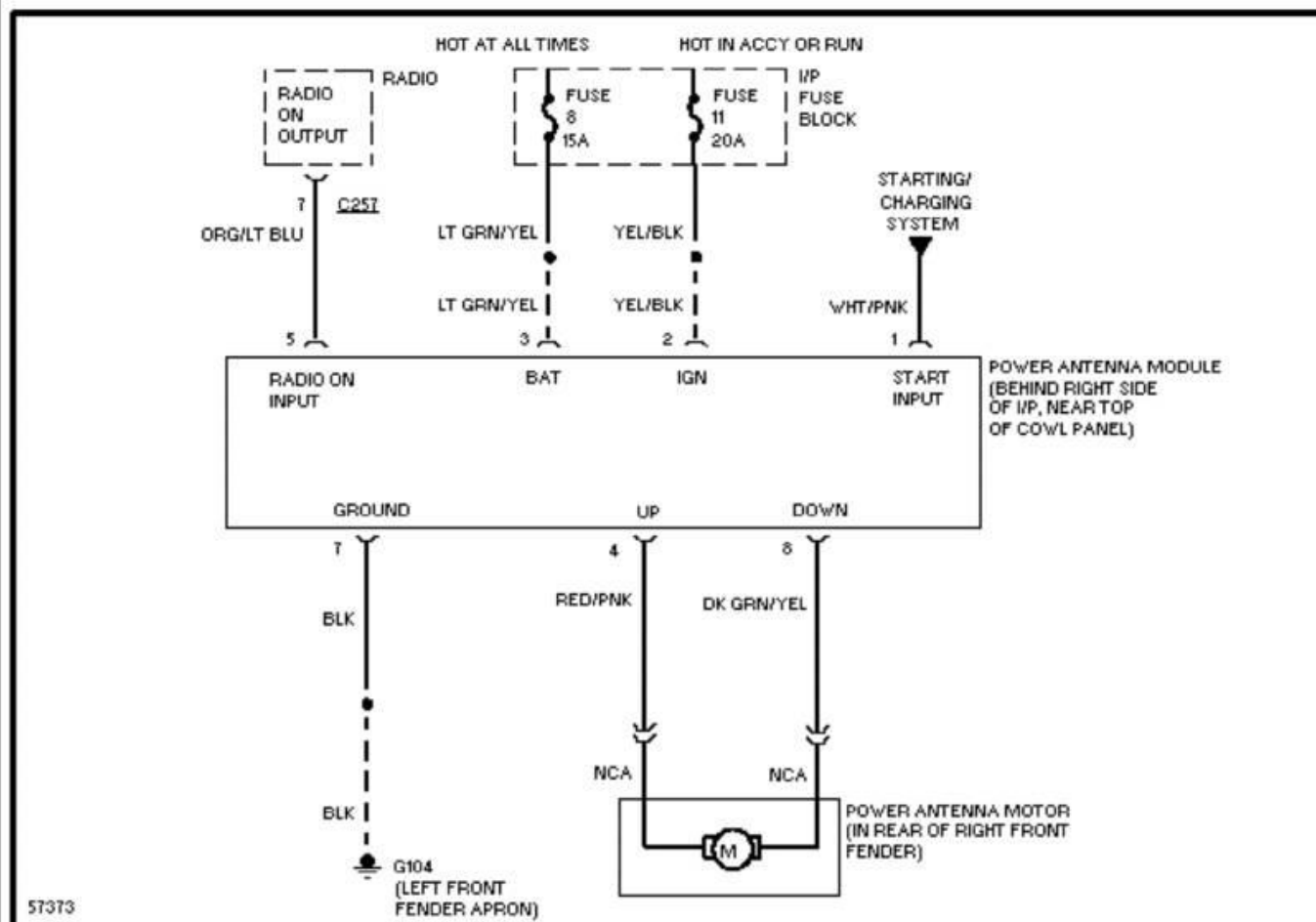

57373

1992 System Wiring Diagrams
Ford - Taurus

PAVLIN

Fig. 7: Door Lock Circuit, W/ Power Windows
1992 Ford Taurus LX

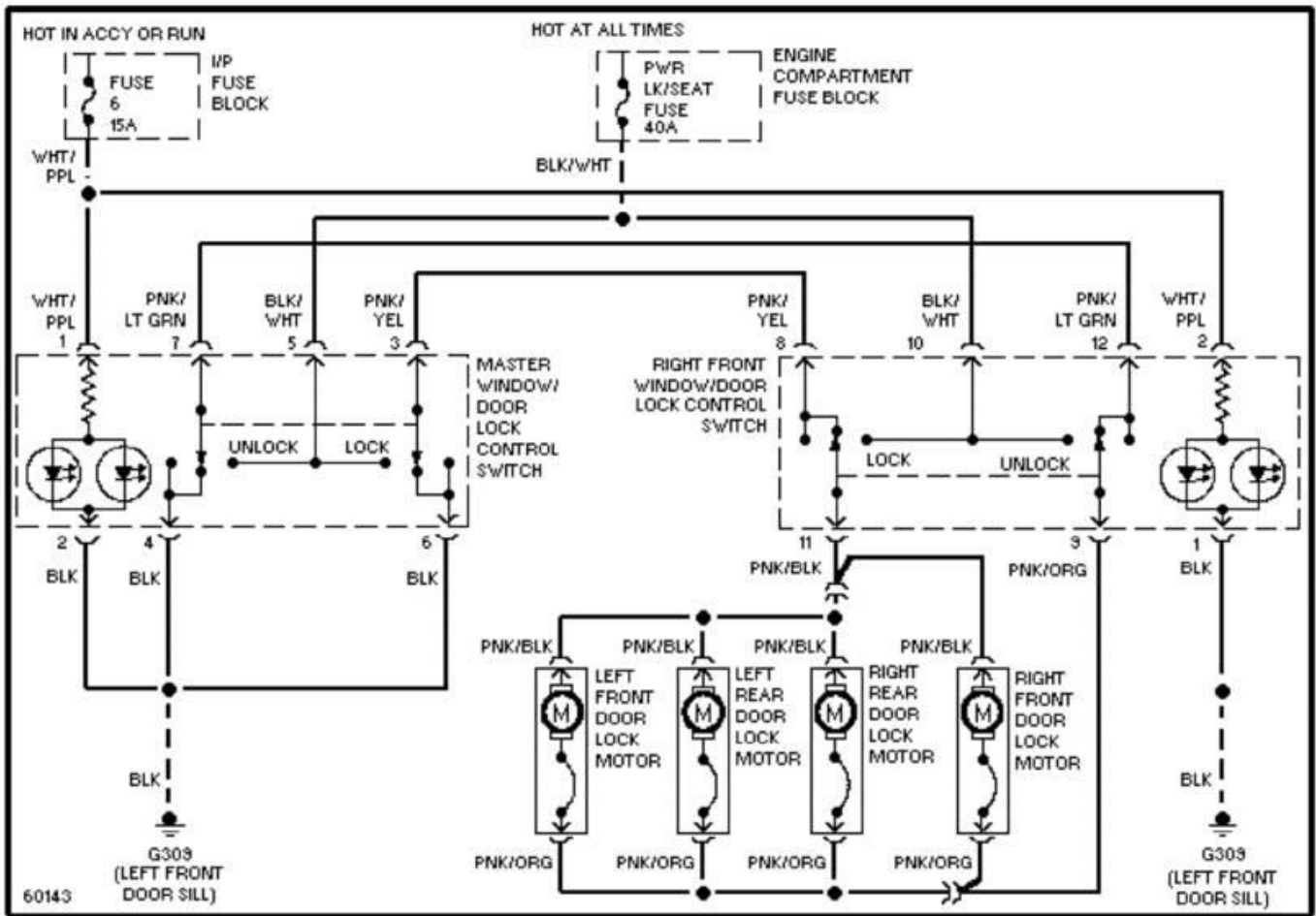

1992 System Wiring Diagrams Ford - Taurus

PAVLIN

Fig. 9: Keyless Entry Circuit
1992 Ford Taurus LX

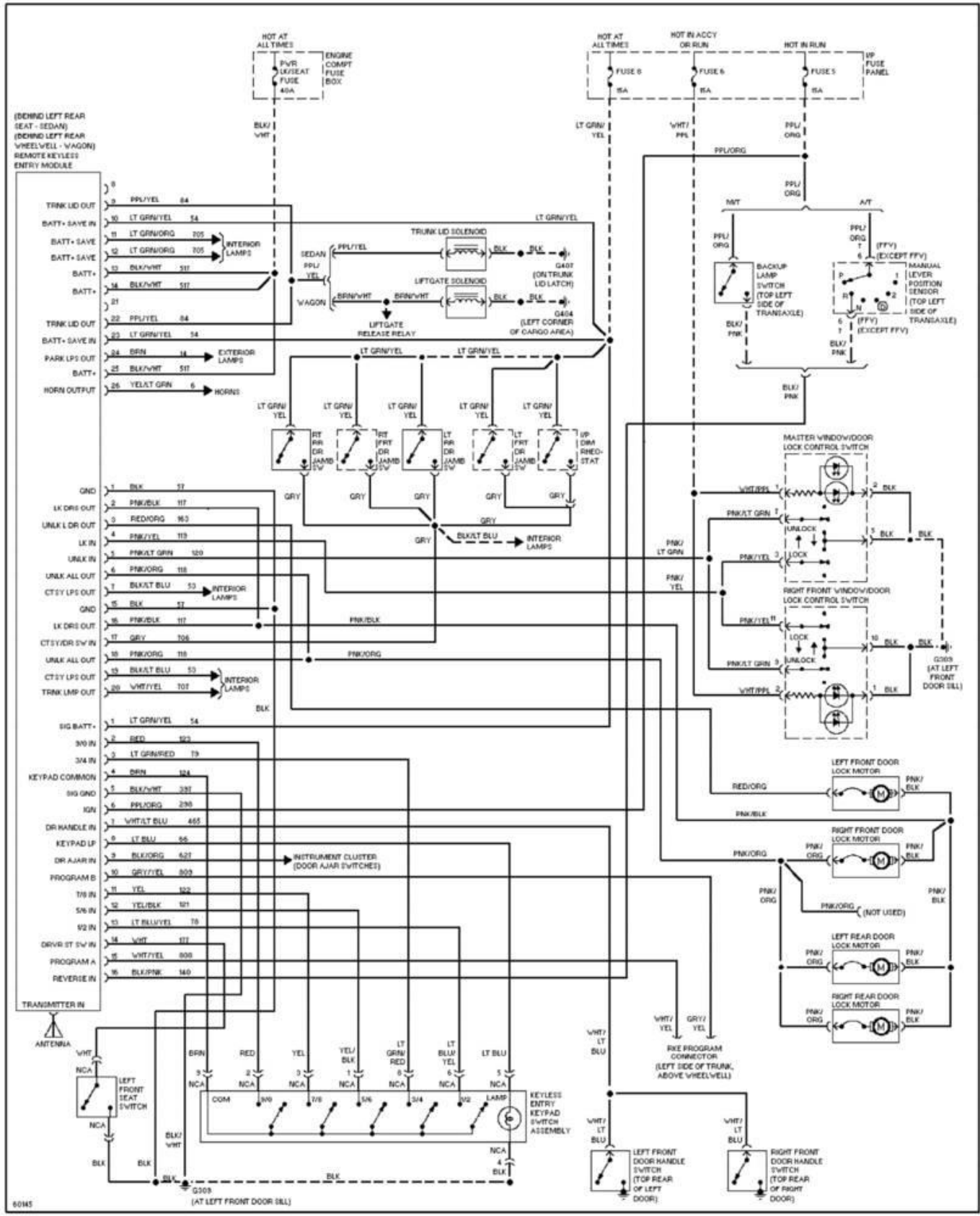

1992 System Wiring Diagrams
Ford - Taurus

PAVLIN

Fig. 10: Power Mirror Circuit
1992 Ford Taurus LX

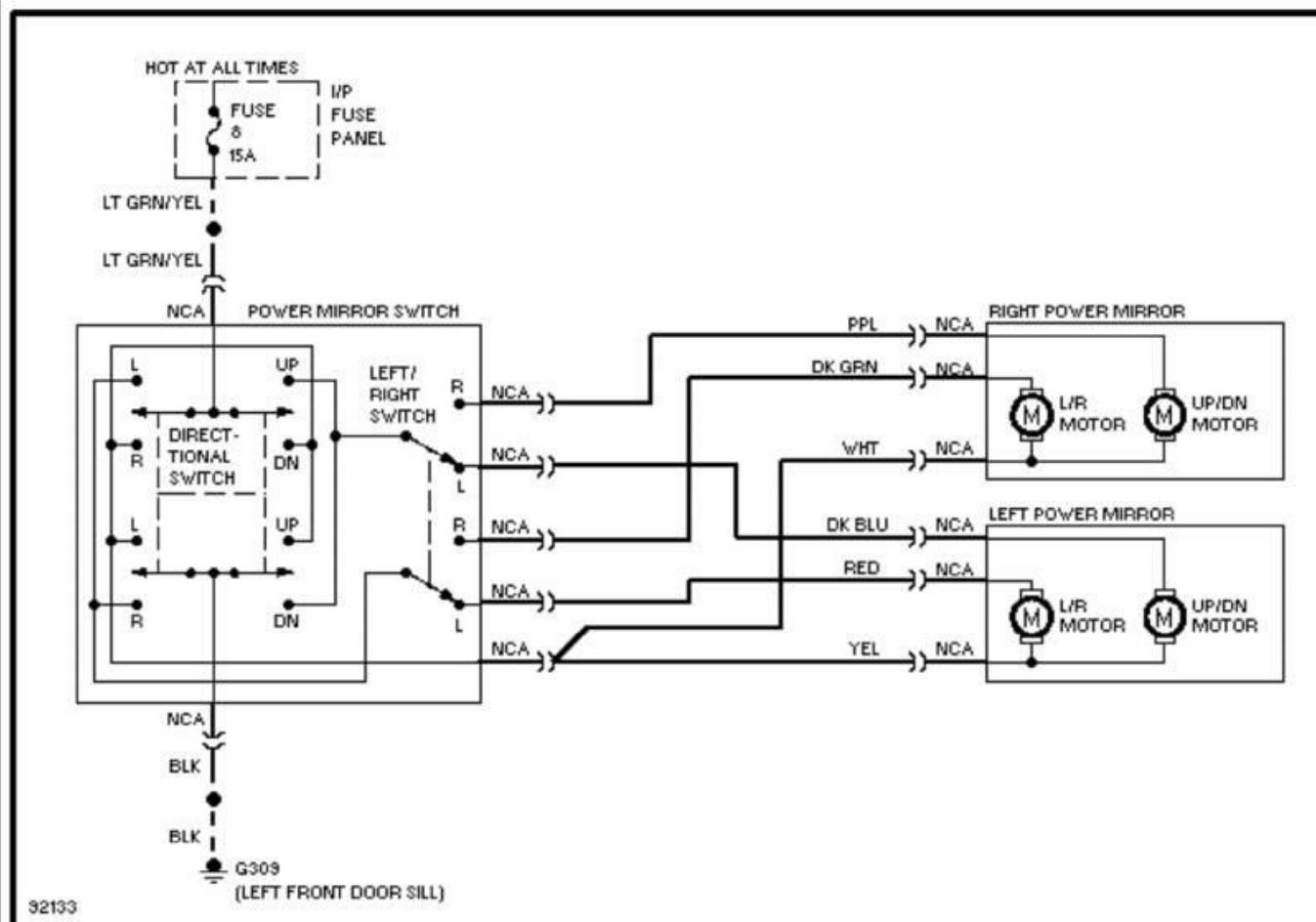

1992 System Wiring Diagrams
Ford - Taurus

PAVLIN

Fig. 11: Lumbar Circuit
1992 Ford Taurus LX

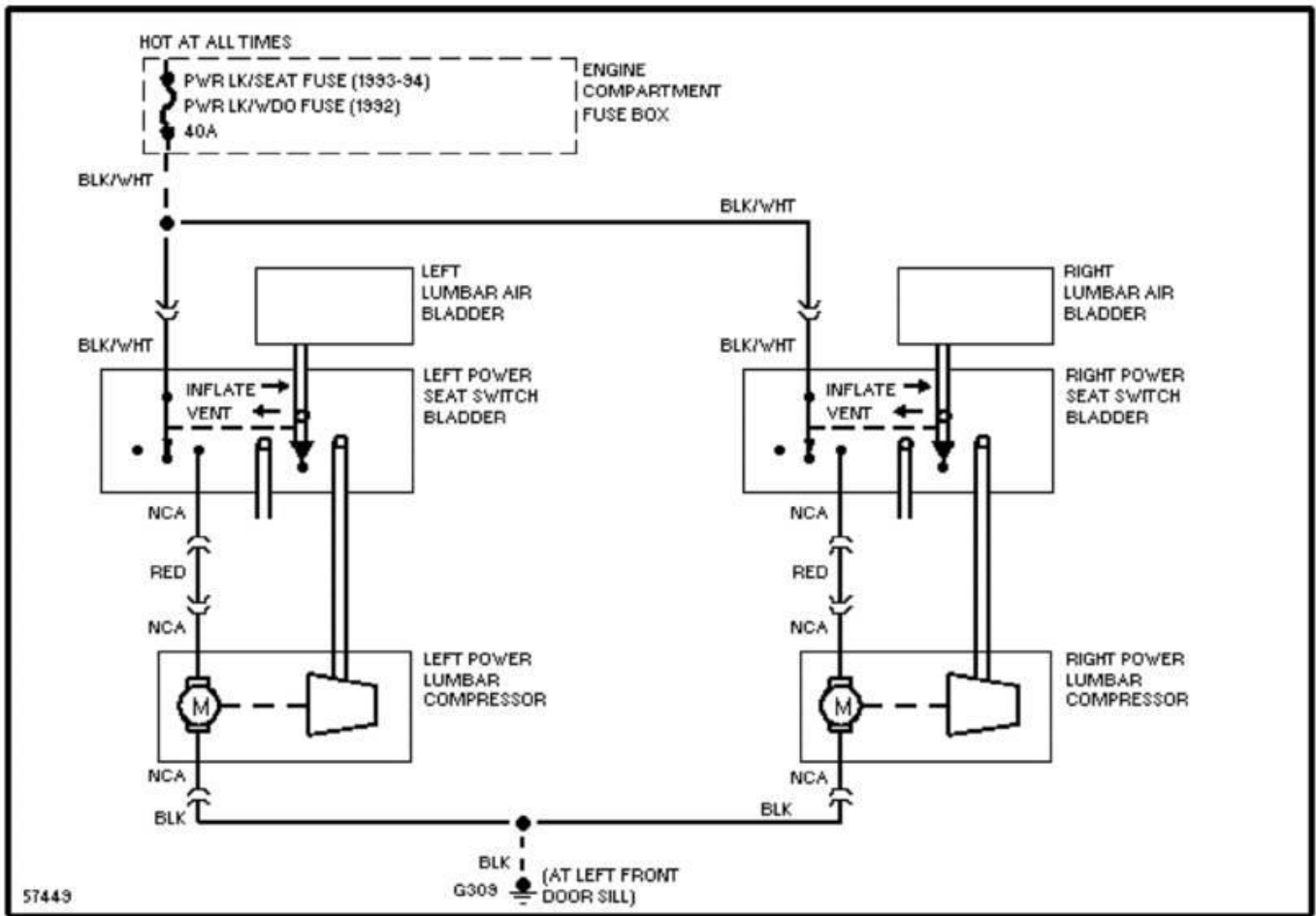

57449

1992 System Wiring Diagrams
Ford - Taurus

PAVLIN

Fig. 12: Power Seat Circuit
1992 Ford Taurus LX

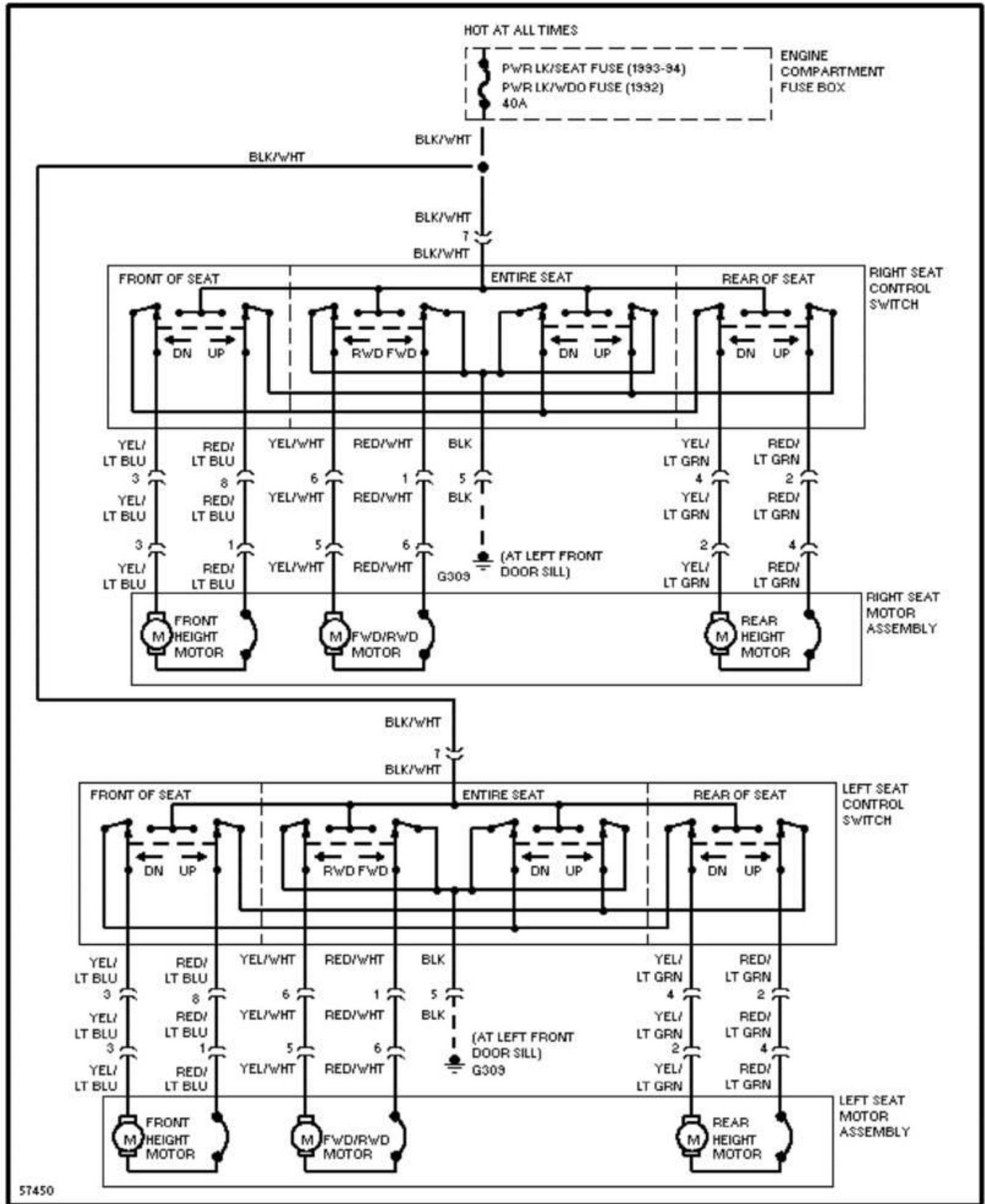

1992 System Wiring Diagrams Ford - Taurus

PAVLIN

Fig. 13: Power Window Circuit
1992 Ford Taurus LX

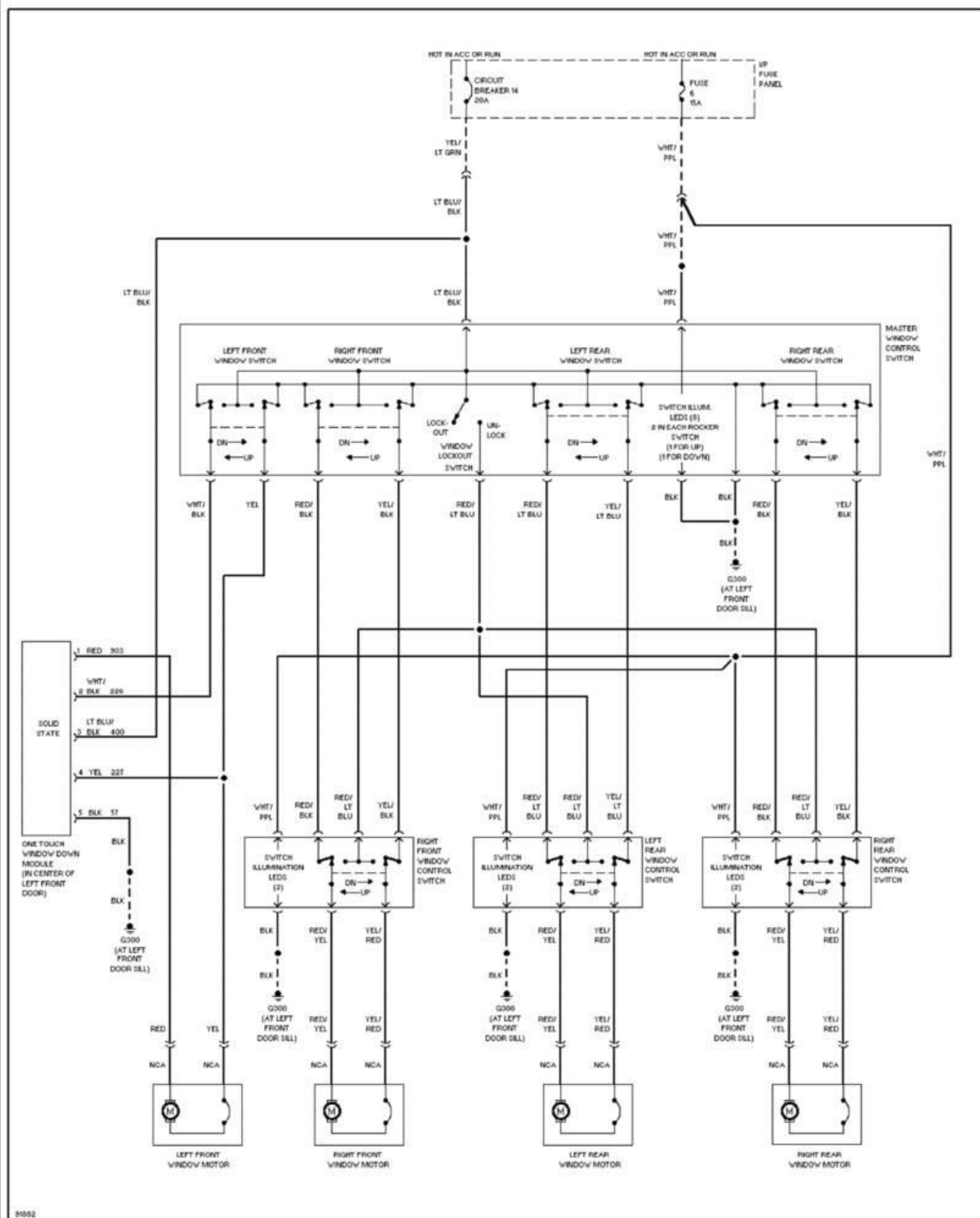

91882

1992 System Wiring Diagrams
Ford - Taurus

PAVLIN

Fig. 14: Radio Circuits, Base Radio W/ Cassette Deck
1992 Ford Taurus LX

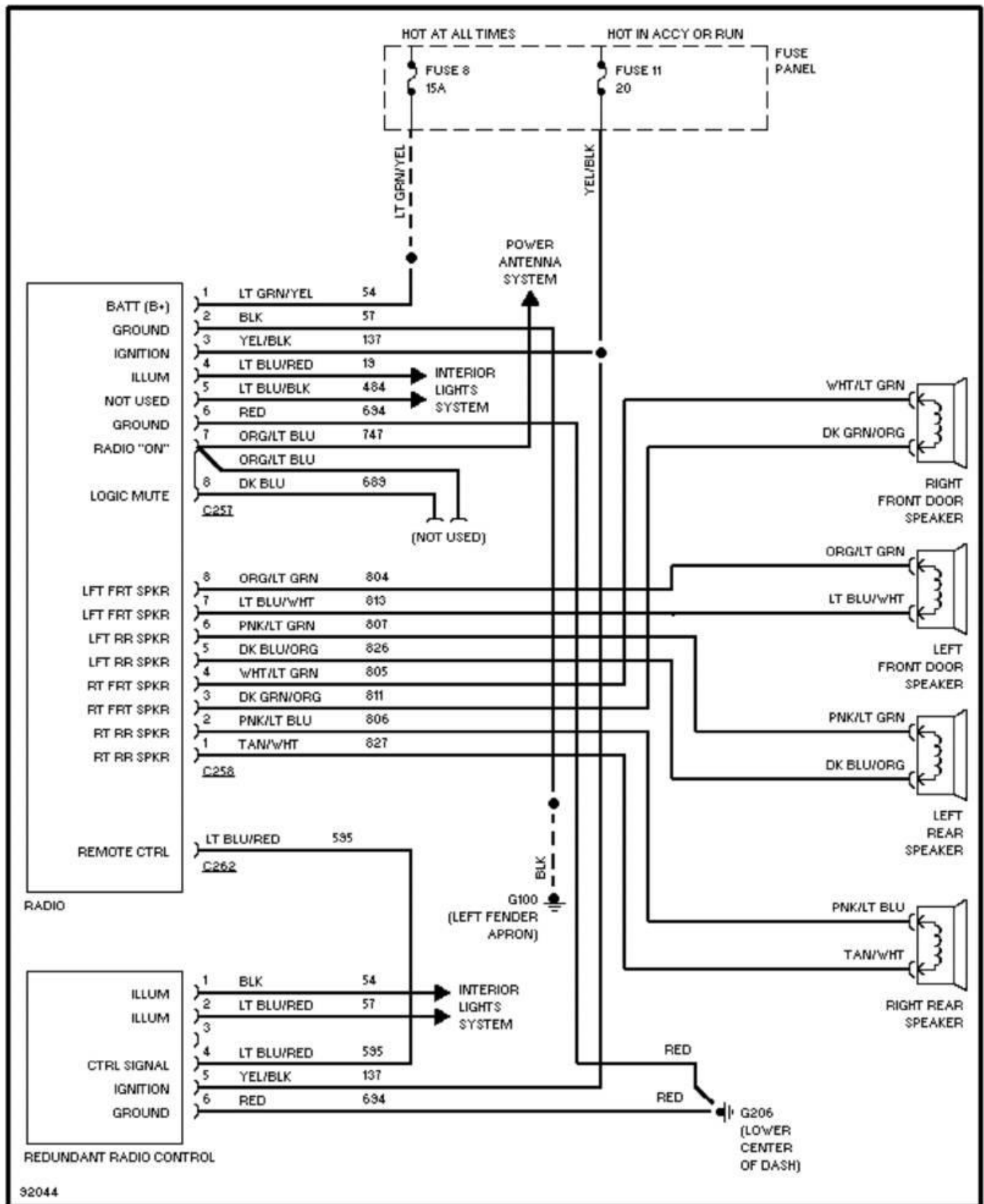

32044

1992 System Wiring Diagrams
Ford - Taurus

PAVLIN

Fig. 16: Charging Circuit
1992 Ford Taurus LX

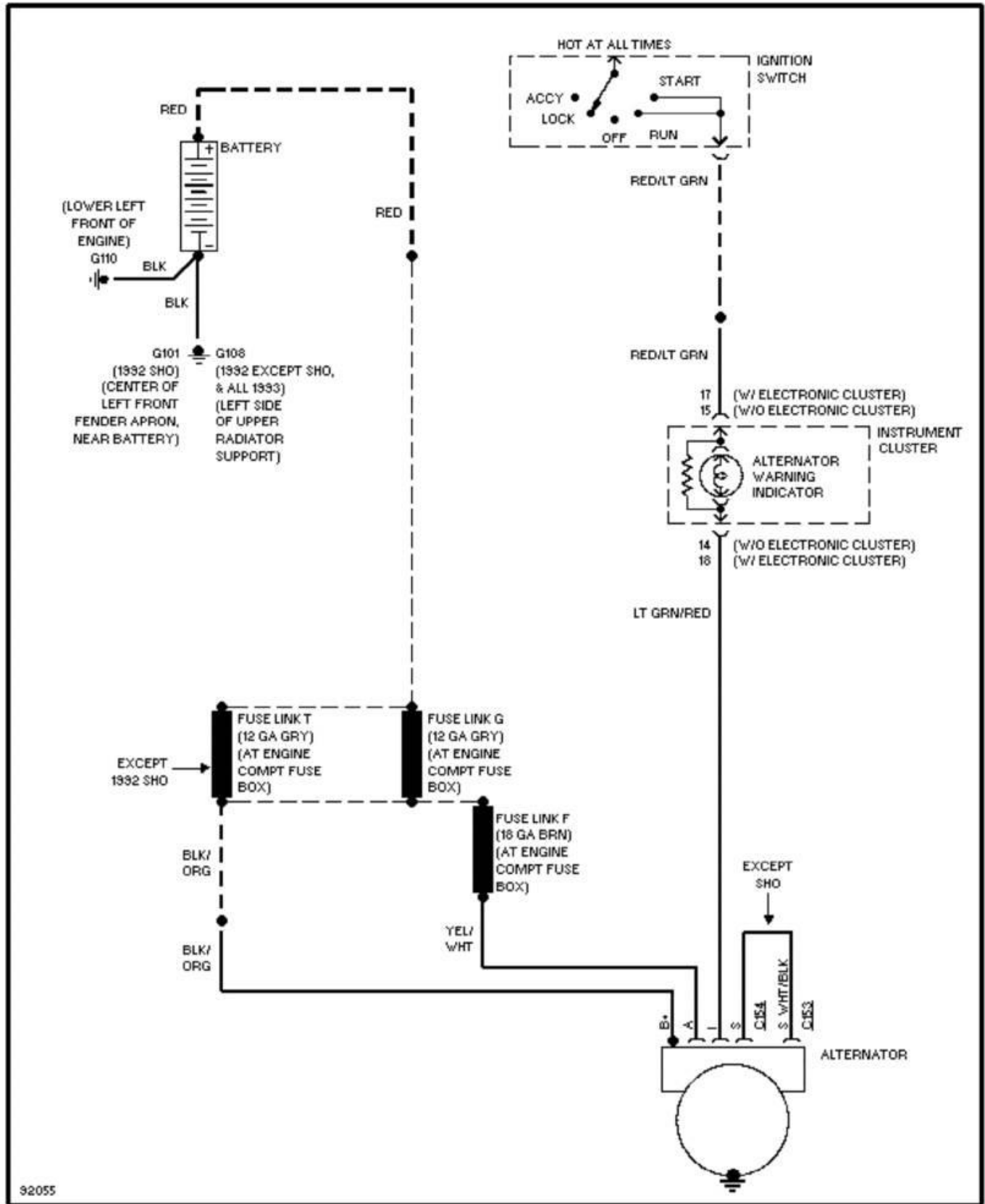

92055

1992 System Wiring Diagrams
Ford - Taurus

PAVLIN

Fig. 17: Starting Circuit
1992 Ford Taurus LX

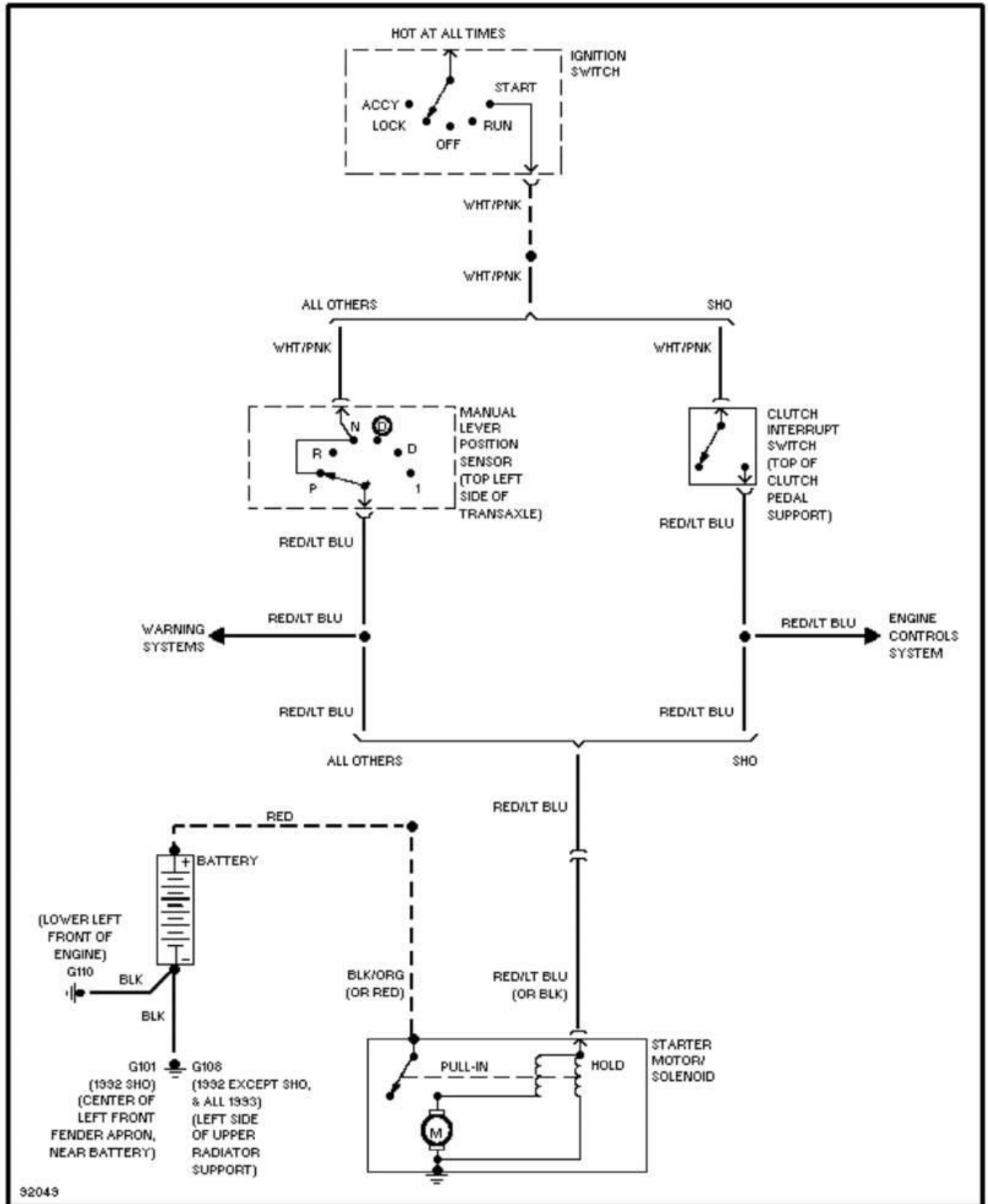

1992 System Wiring Diagrams
Ford - Taurus

PAVLIN

Fig. 18: Tailgate Release Circuit
1992 Ford Taurus LX

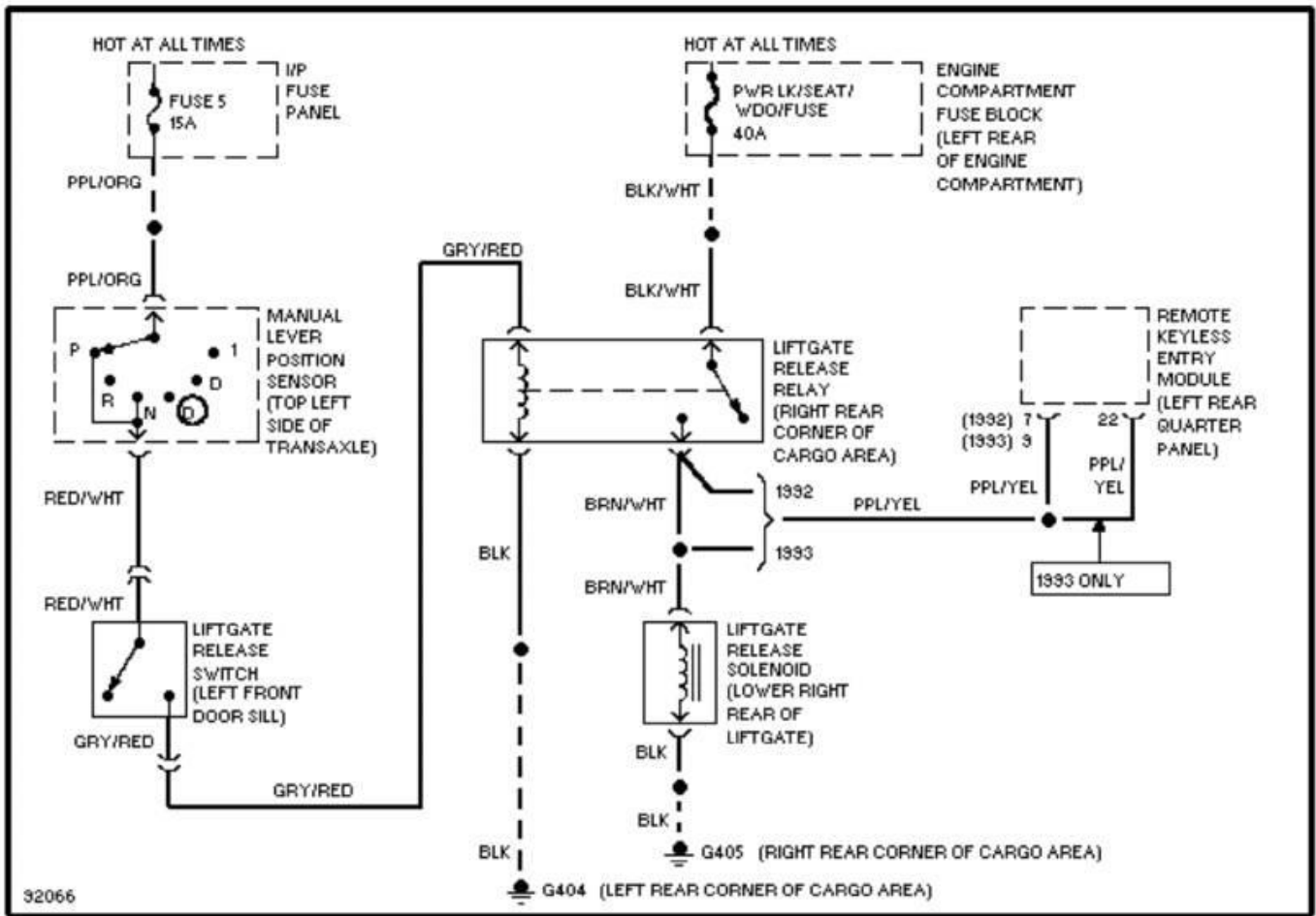

1992 System Wiring Diagrams
Ford - Taurus

PAVLIN

Fig. 19: Trunk Release Circuit
1992 Ford Taurus LX

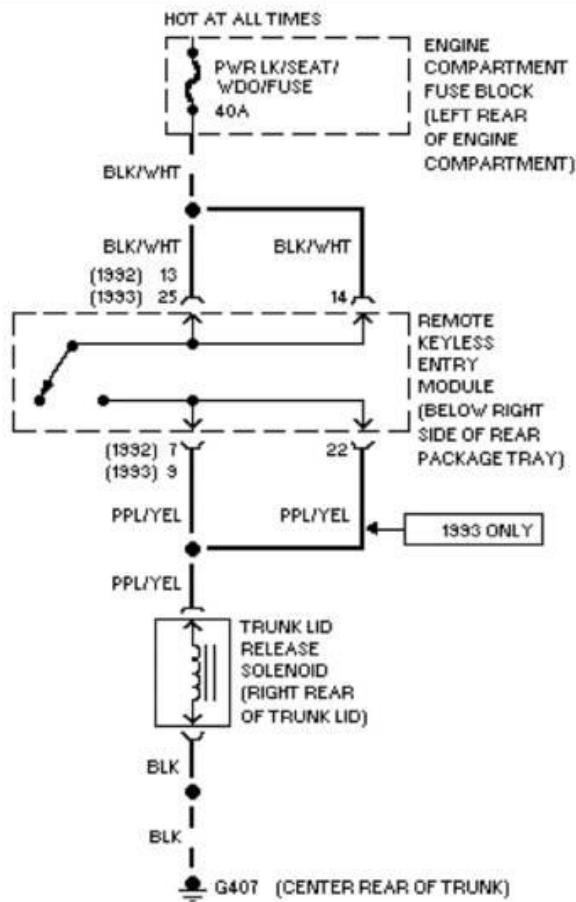

92065

1992 System Wiring Diagrams Ford - Taurus

PAVLIN

Fig. 20: Interval Wiper/Washer Circuit
1992 Ford Taurus LX

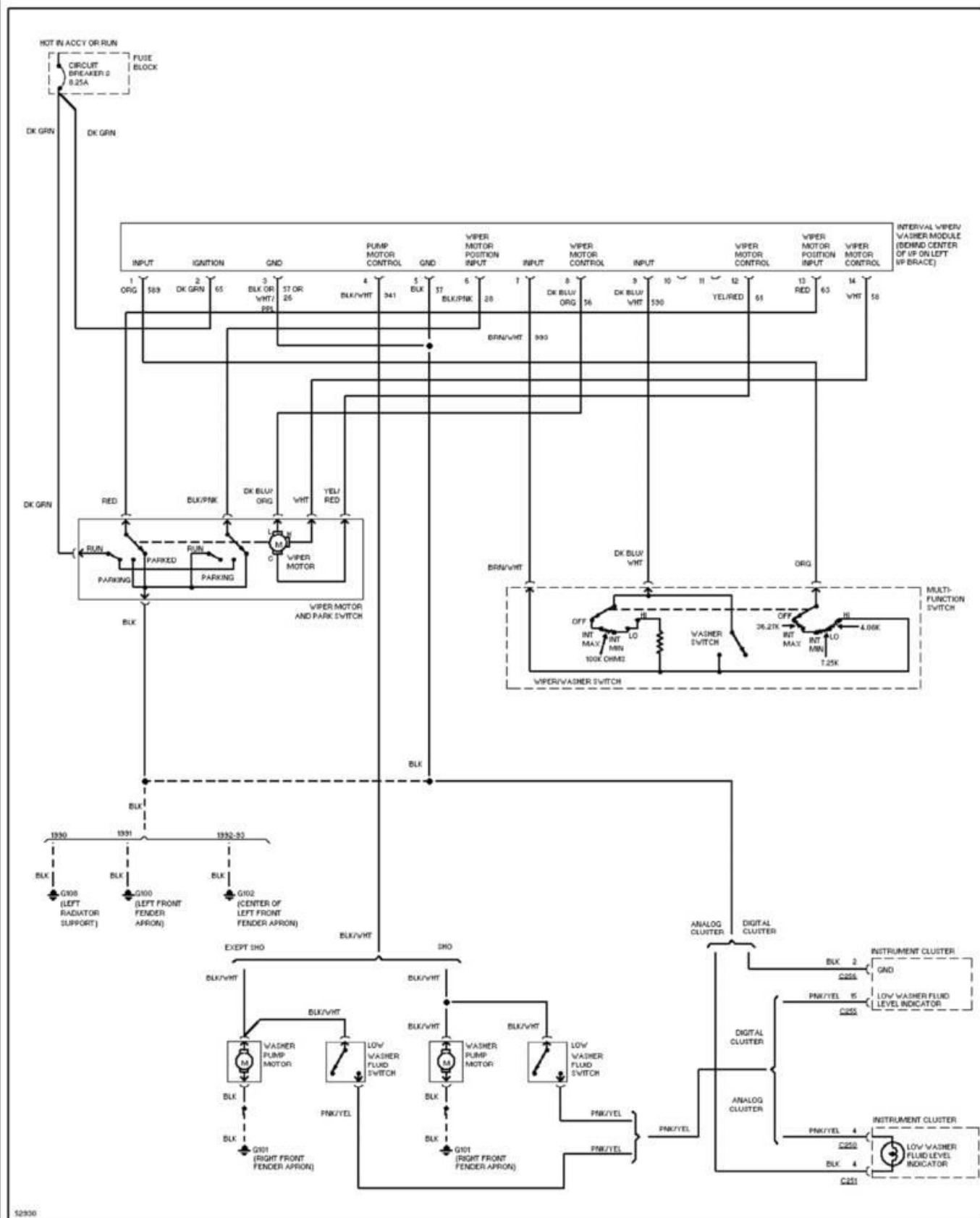

1992 System Wiring Diagrams
Ford - Taurus

PAVLIN

Fig. 21: Rear Wiper/Washer Circuit
1992 Ford Taurus LX

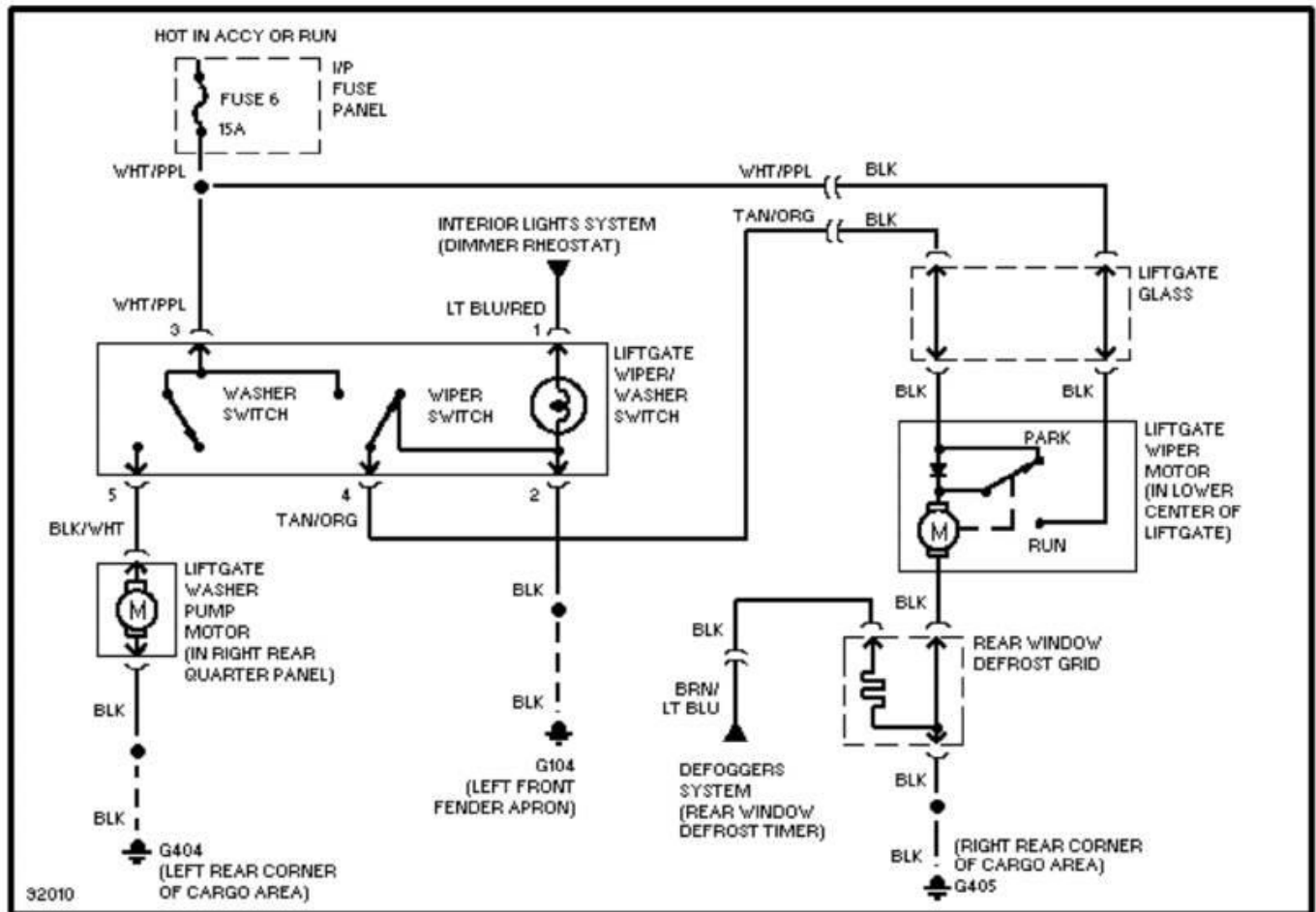

WIRING DIAGRAMS

1991 Wiring Diagrams Ford Motor Co.

PAVLIN

Fig. 1: Headlights (3.0L SHO) & (Except 3.0L SHO) (Grid 1-3)
1992 Ford Taurus LX

COMPONENT LOCATOR:

A/C HEATER SYSTEM	A-D 51
AIRBAG SYSTEM	A-C 52-55
ALTERNATORS	G 7
ANTI-LOCK BRAKE SYSTEM	A-E 44-47
AUTOLAMPS	D-E 61-63
BATTERY	A 6
BRAKE FLUID LEVEL SW	C 64
CLOCK/SRING ASSY	D 39
CLUTCH INTERRUPT START SW (3.0L SHO)	B 6
COOLING FAN (3.0L SHO)	E 22
COOLING FAN (3.0L)	E 30
COURTESY LTS	A-C 69-73
CRUISE CONTROL SYSTEM	A-C 39
DIS MODULE (3.0L SHO)	A-D 48
EATC CONTROL SYSTEM	A-D 48
ELECT ENGINE CONTROL (ECC) MOD (3.0L SHO)	A-D 16
ELECT ENGINE CONTROL (ECC) MOD (3.0L)	A-D 8
ELECT ENGINE CONTROL (ECC) MOD (3.0L)	A-D 24
ENGINE COMPT FIB	C-E 4
ENGINE COMPT LT	A 6
FOG LT IN-LINE FUSE	C 2
FOG LT RELAY (3.0L SHO)	C 9
FOG LT SW	E 59
FUEL PUMP/FUEL GAUGE SENDER	B 80
FUSE BLOCK (F/B)	C-D 33-34
GEAR SELECT SW (EX 3.0L SHO)	C-E 55
GROUND A	D 1-2
GROUND B	D 1-2
GROUND C	A 5
GROUND D	B 5
GROUND E (3.0L SHO)	A 18
GROUND E (3.0L)	E 10
GROUND E (3.0L)	B 26
GROUND F (3.0L SHO)	D 18
GROUND H	A-E 40
GROUND I	E 46
GROUND J	D 50
GROUND K	D-E 52
GROUND L	E 52
GROUND M	E 42
GROUND N	A 71
GROUND O	B-D 76
GROUND P	B 80-82
HEATER SYSTEM	E 48-51
HEGO SENSORS (3.0L SHO)	A 21
HEGO SENSORS (3.0L)	A 15
HEGO SENSORS (3.0L)	A 31
HORN RELAY	E 39
IGNITION COIL (3.0L)	E 11
IGNITION COIL (3.0L)	D 27
IGNITION SW	A 33-35
ILLUMINATED ENTRY TIMER	D 60
INERTIA SW (3.0L SHO)	D 22
INERTIA SW (3.0L)	C 16
INST PANEL DIMMING RHEOSTAT	D 63
INSTRUMENT CLUSTER (ANALOG/SHO)	A 64-67
INSTRUMENT CLUSTER (DIGITAL)	E 64-67
INTEGRATED RELAY CONTROLLER (MOD 3.0L SHO)	C-E 23
INTEGRATED RELAY CONTROLLER (MOD 3.0L)	C-E 15
INTEGRATED RELAY CONTROLLER (MOD 3.0L)	C-E 31
KEYLESS ENTRY SYSTEM	B-E 78
LAMP OUT WARNING MODULE	A 69
LIFTGATE RELEASE	D 68-69
LOW OIL LEVEL RELAY	B 67
MAIR LT SW	E 50
MOONROCK	E 88-91
MULTI-FUNCTION SW	A-D 56
POLICE ACCY RELAY	B 4
POWER ANTENNA MODULE	D 69
POWER DOOR LOCKS (W/ KEYLESS ENTRY)	A 78-79
POWER DOOR LOCKS (W/O KEYLESS ENTRY)	A-B 72-73
POWER MIRROR SW	E 76
POWER SEATS	C-E 75
POWER WINDOWS	C-E 72-74
RADIATOR COOLANT SENSOR (3.0L SHO)	C 67
REAR WINDOW DEFOG	A-C 68-71
REAR WIPER WASHER	B-D 71
SEAT BELT SW	C 52
SELF TEST OUTPUT (STO) CONN (3.0L SHO)	C 20
SELF TEST OUTPUT (STO) CONN (3.0L)	C 12
SHIF LOCK ACTUATOR	D 52
STARTER MOTOR	A 7
STOP LT SW	A 56
VAPS MODULE	E 7
VEHICLE SPEED SENSOR	C 7
WARNING CHIME MODULE	C 52
WINDSHIELD WIPER/WASHER SYS	D-E 54-59

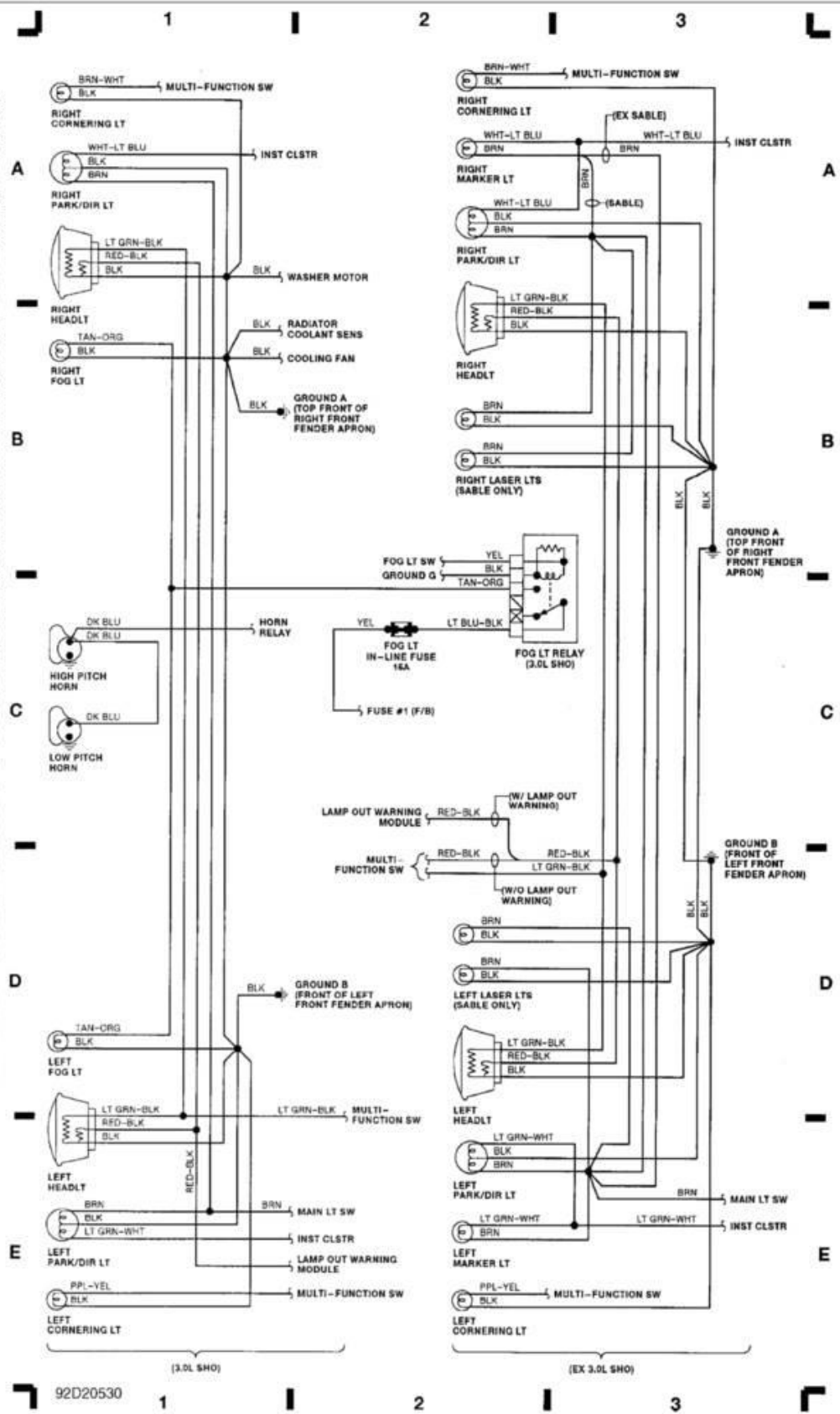

WIRING DIAGRAMS

1991 Wiring Diagrams Ford Motor Co.

PAVLIN

Fig. 2: Engine Compartment, VAPS, Engine Compartment F/B (Grid 4-7)
1992 Ford Taurus LX

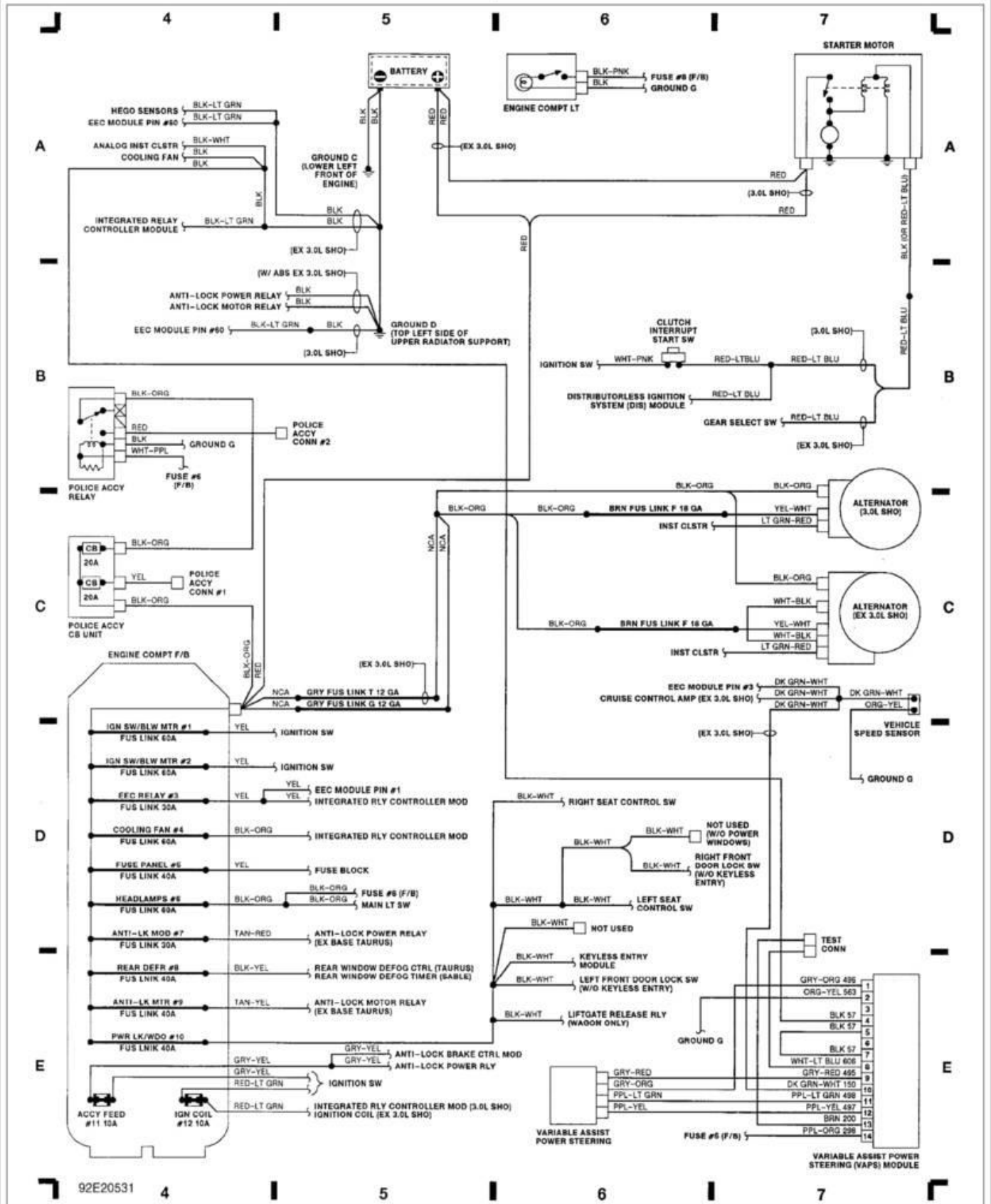

WIRING DIAGRAMS

1991 Wiring Diagrams Ford Motor Co.

PAVLIN

Fig. 3: Electronic Engine Control (3.0L) (Grid 8-11)
1992 Ford Taurus LX

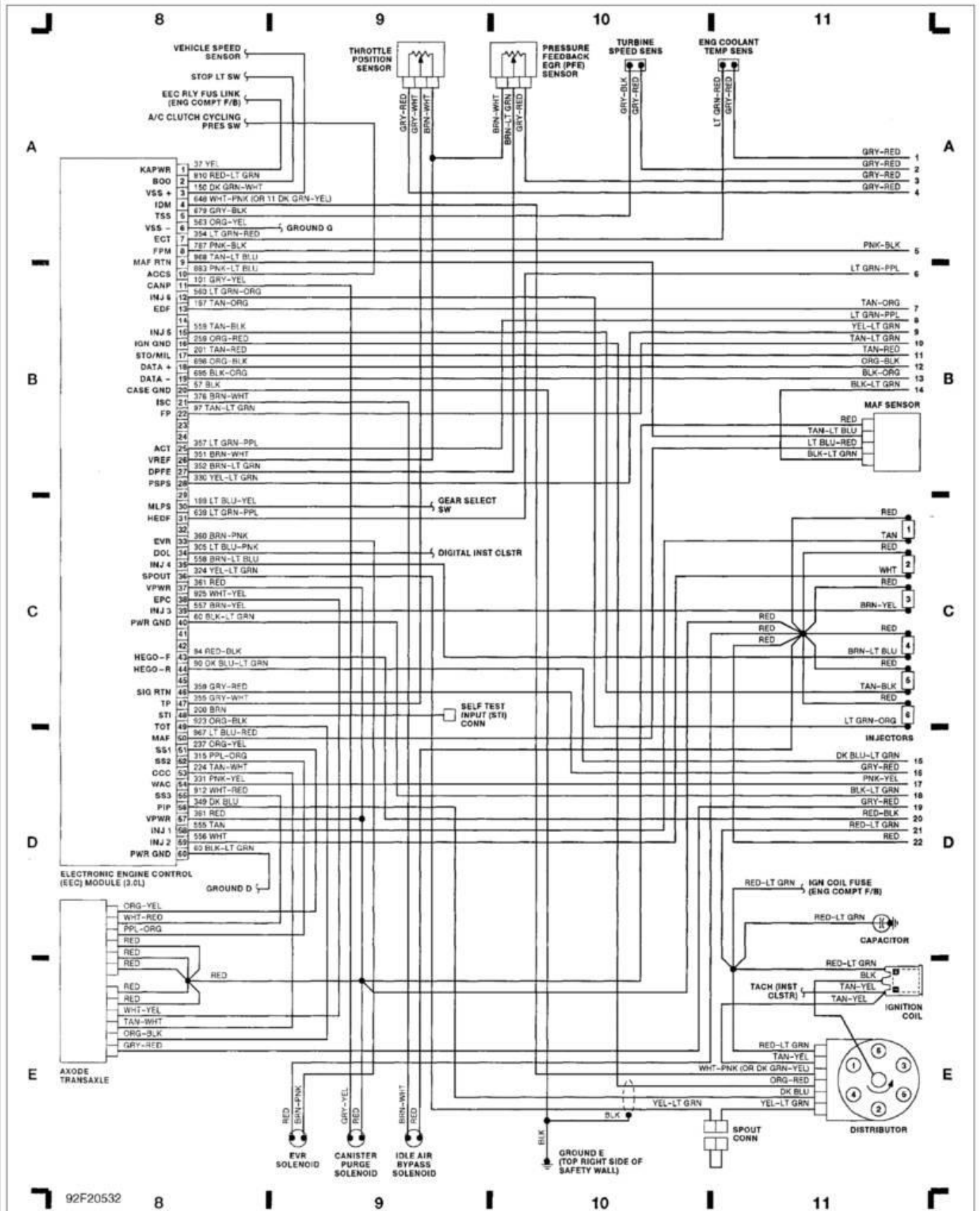

WIRING DIAGRAMS
1991 Wiring Diagrams Ford Motor Co.

PAVLIN

Fig. 4: Integrated Relay Controller Module (3.0L) (Grid 12-15)
 1992 Ford Taurus LX

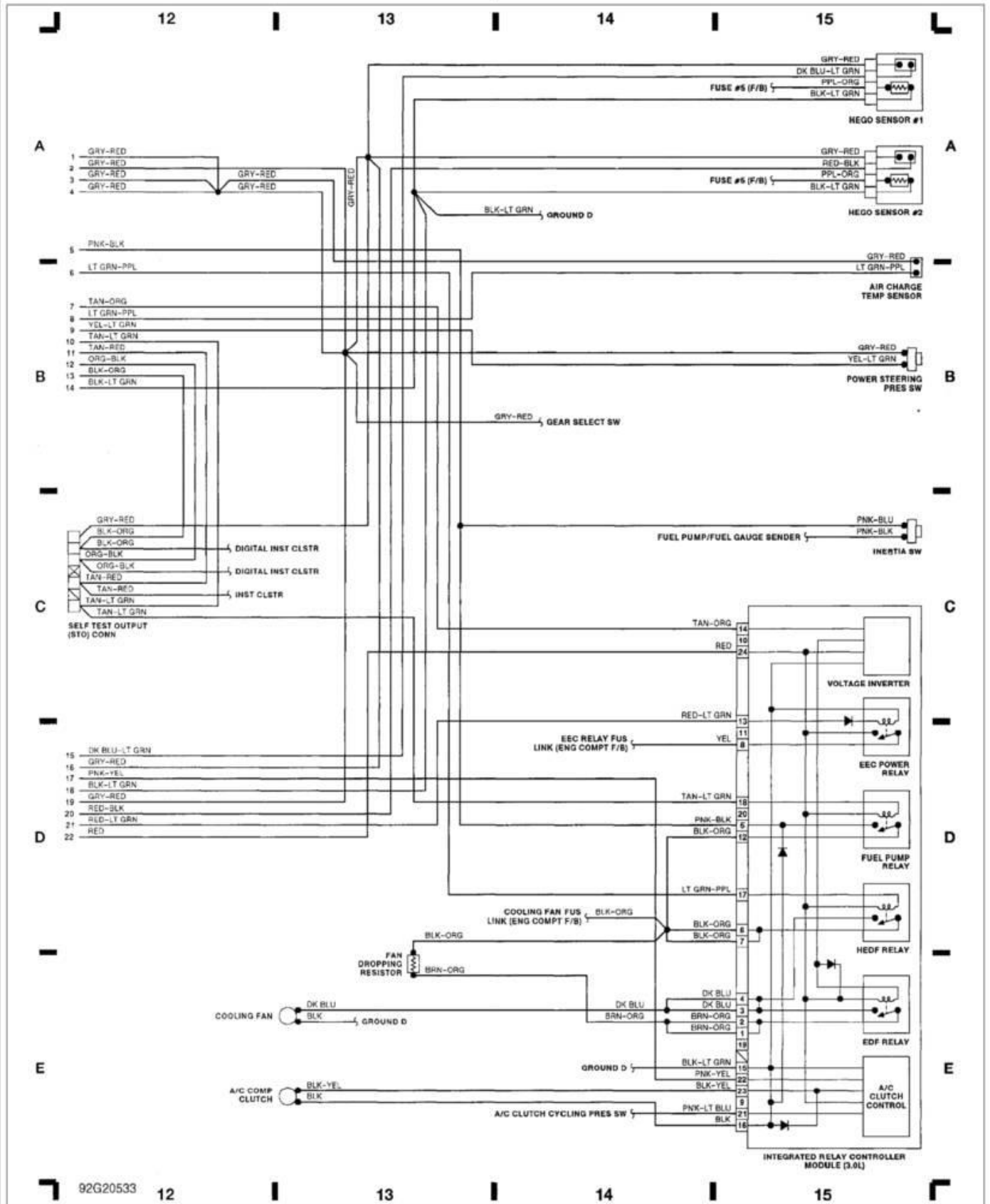

92G20533

WIRING DIAGRAMS

1991 Wiring Diagrams Ford Motor Co.

PAVLIN

Fig. 5: Electronic Engine Control (3.0L SHO) (Grid 16-19)
1992 Ford Taurus LX

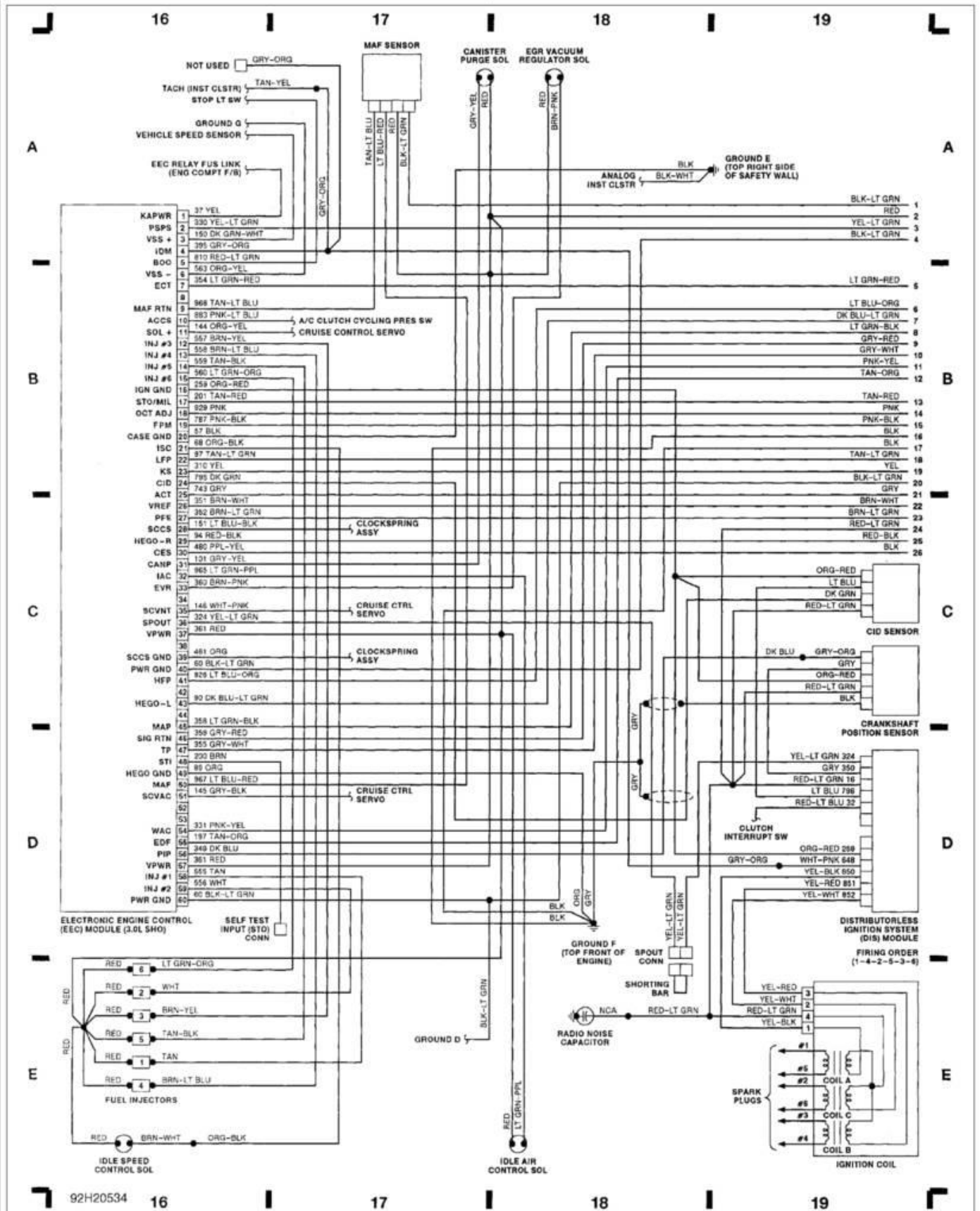

WIRING DIAGRAMS

1991 Wiring Diagrams Ford Motor Co.

PAVLIN

Fig. 6: Integrated Relay Controller Module (3.0L SHO)
 (Grid 20-23)
 1992 Ford Taurus LX

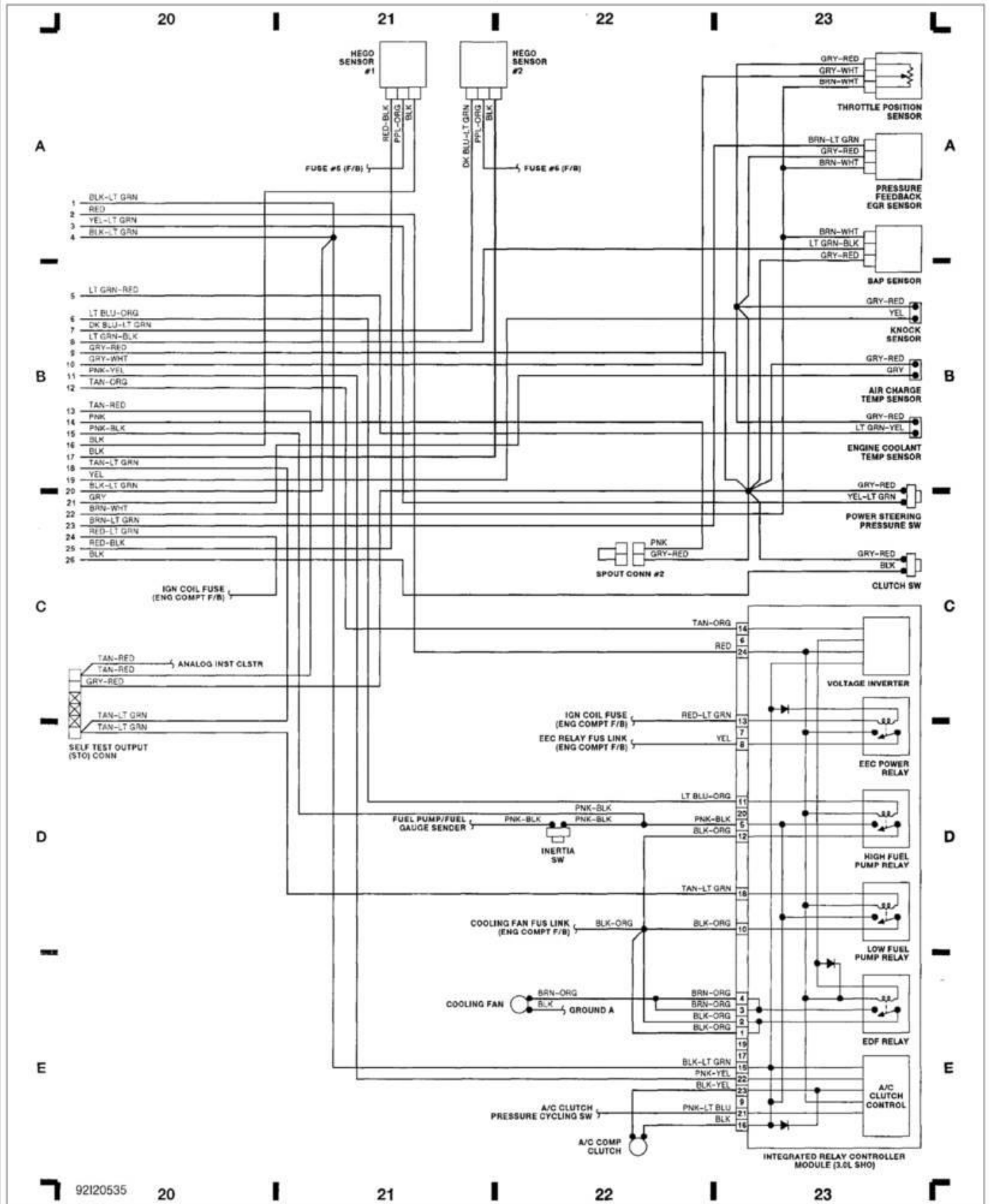

92I20535

WIRING DIAGRAMS

1991 Wiring Diagrams Ford Motor Co.

PAVLIN

Fig. 7: Electronic Engine Control (3.8L) (Grid 24-27)
1992 Ford Taurus LX

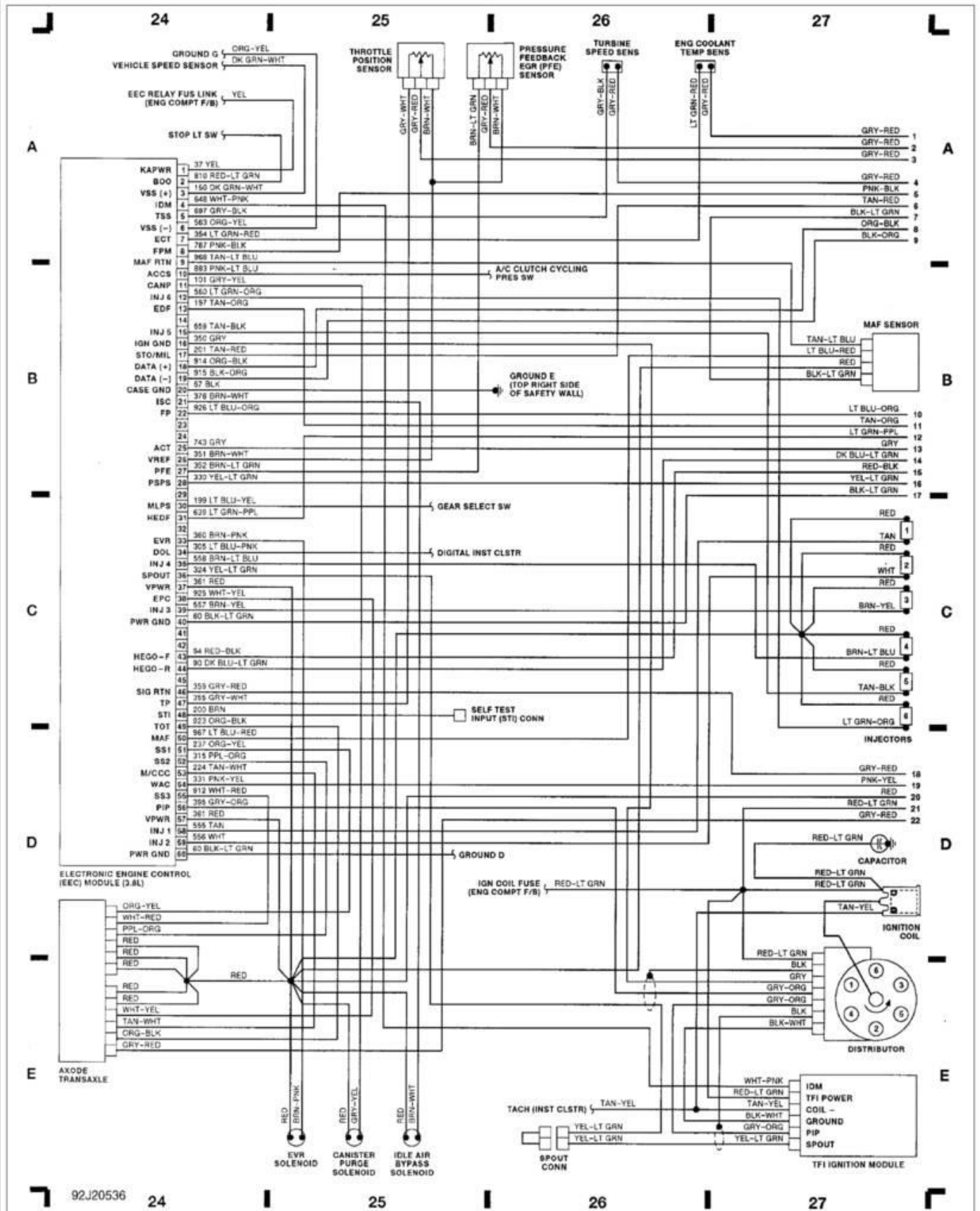

WIRING DIAGRAMS
1991 Wiring Diagrams Ford Motor Co.

PAVLIN

Fig. 8: Integrated Relay Controller Module (3.8L) (Grid 28-31)
 1992 Ford Taurus LX

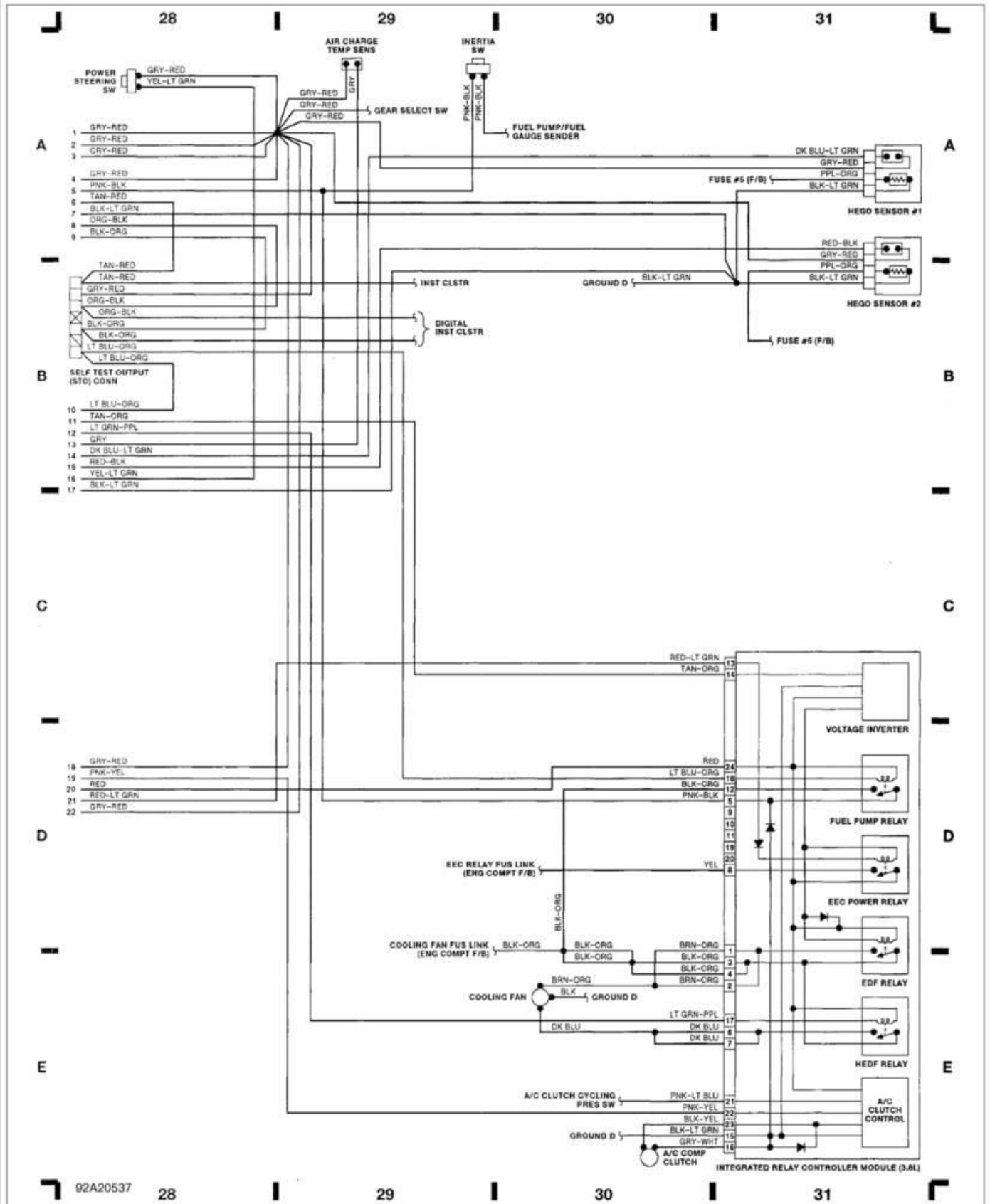

WIRING DIAGRAMS

1991 Wiring Diagrams Ford Motor Co.

PAVLIN

Fig. 9: Ignition Switch, Fuse Block (F/B) (Grid 32-35)
1992 Ford Taurus LX

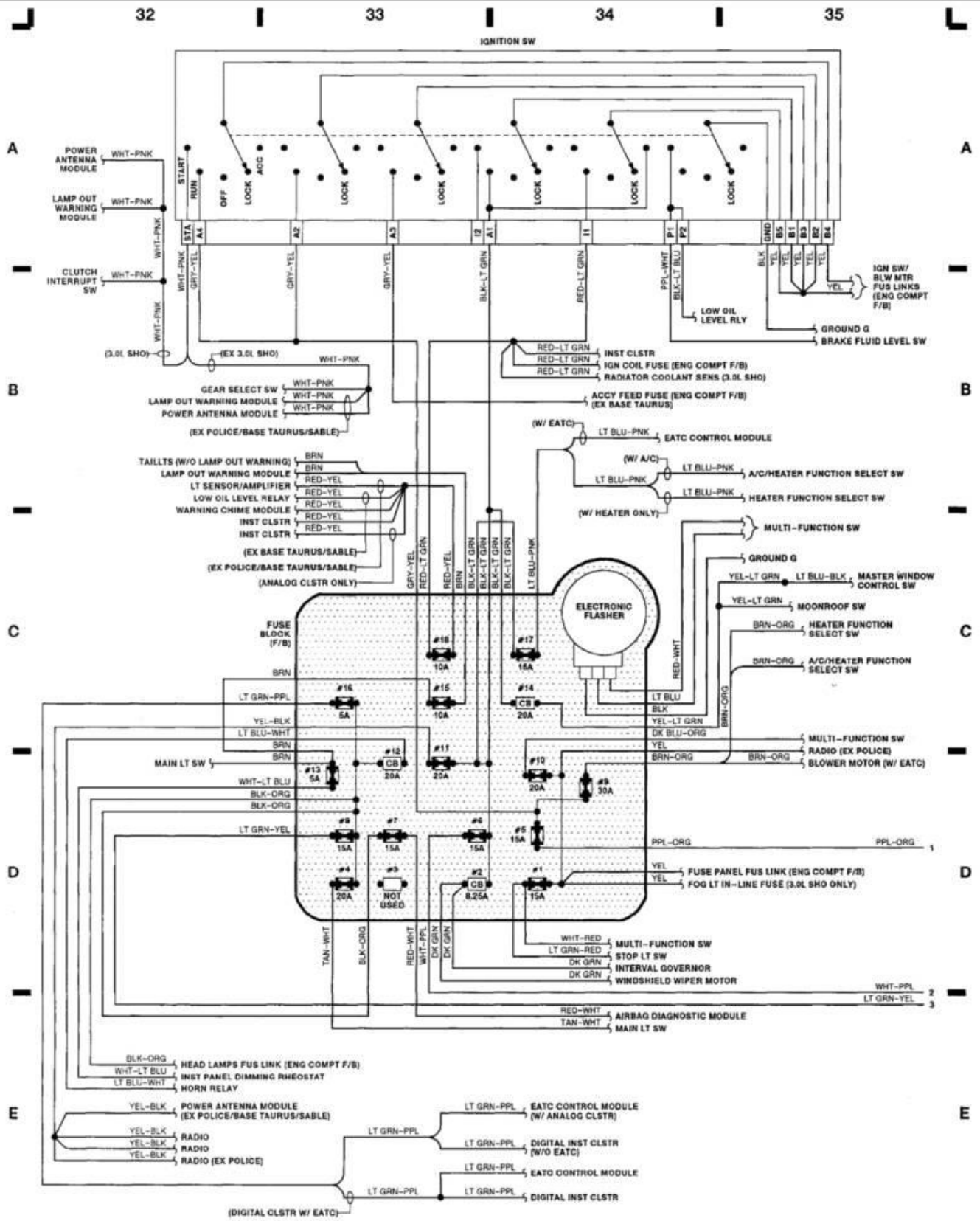

92B20538

WIRING DIAGRAMS
1991 Wiring Diagrams Ford Motor Co.

PAVLIN

Fig. 10: Cruise Control, Clockspring/Slip Ring Assy (Grid 36-39)
 1992 Ford Taurus LX

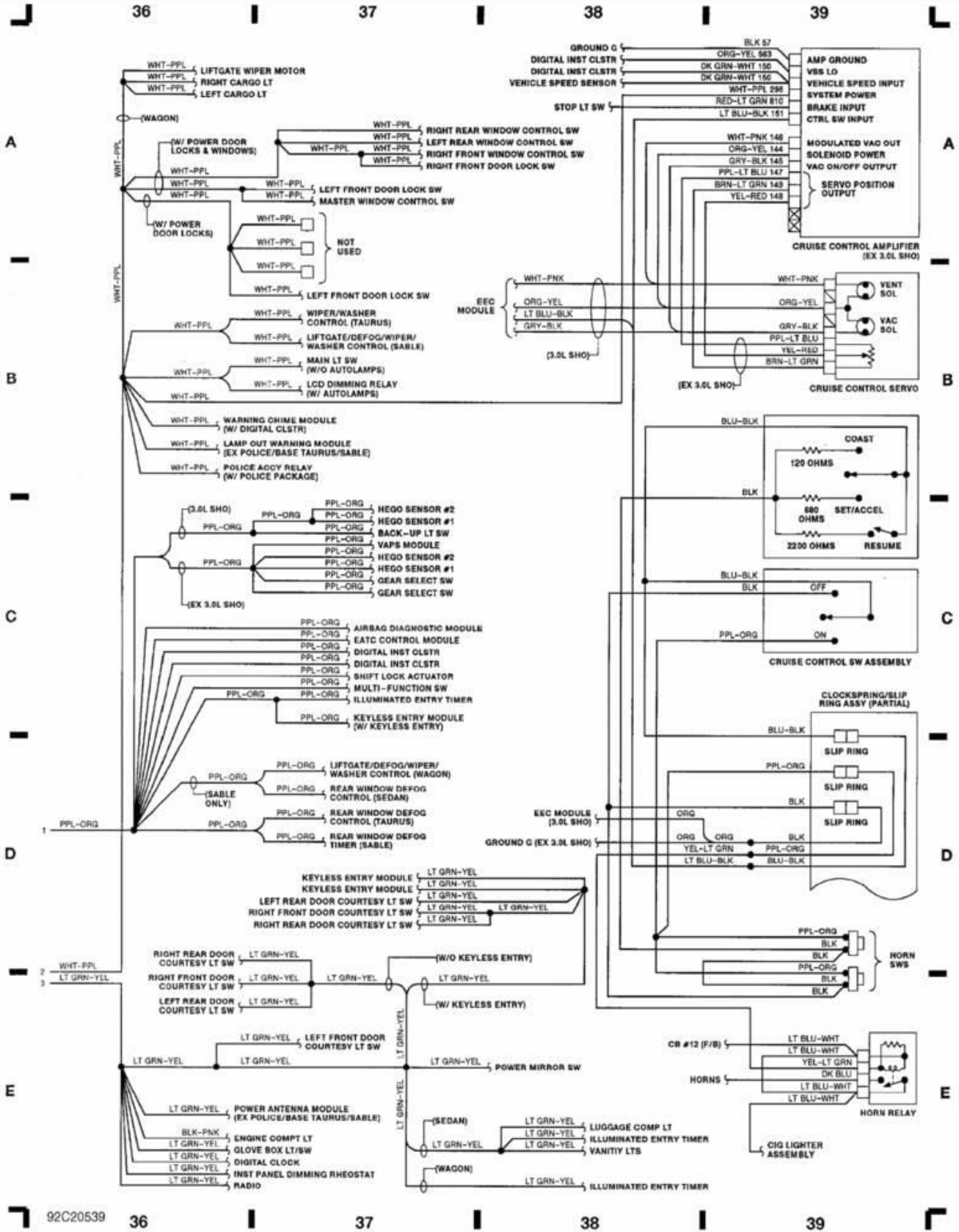

92C20539

WIRING DIAGRAMS

1991 Wiring Diagrams Ford Motor Co.

PAVLIN

Fig. 11: Ground G Locations (All Models) (Grid 40-43)
1992 Ford Taurus LX

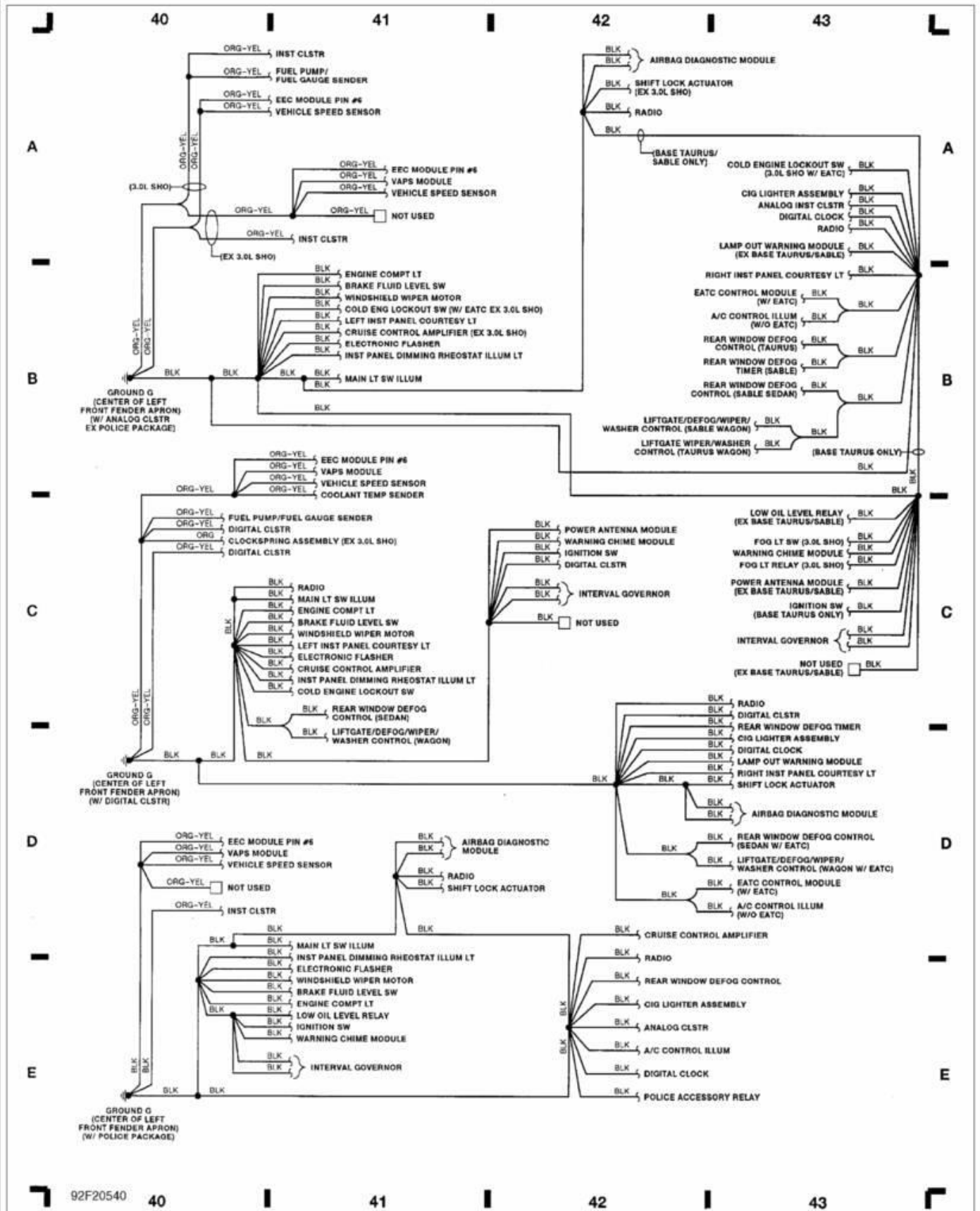

92F20540

WIRING DIAGRAMS

1991 Wiring Diagrams Ford Motor Co.

PAVLIN

Fig. 12: Anti-Lock Brake Control Module (Grid 44-47)
1992 Ford Taurus LX

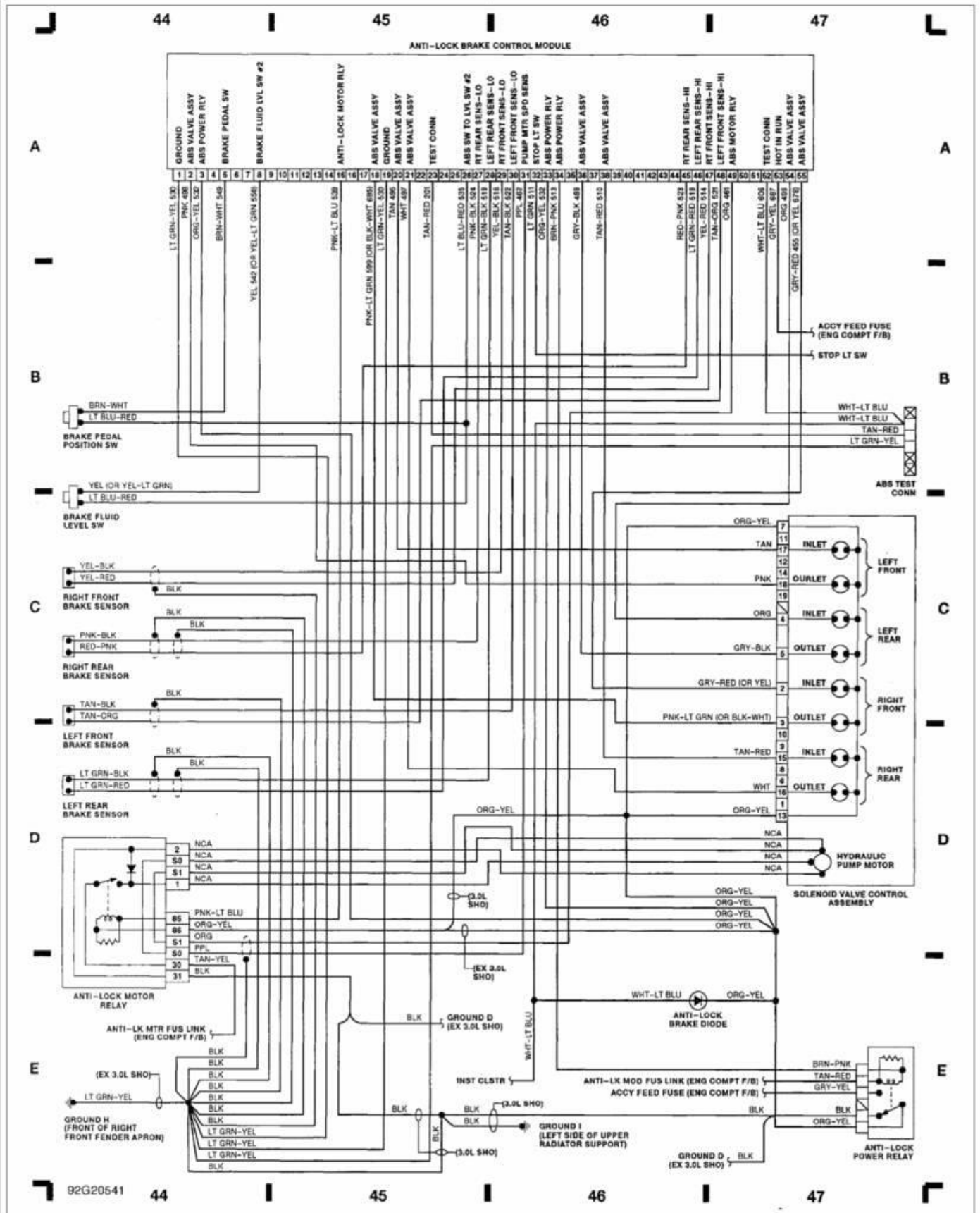

WIRING DIAGRAMS

1991 Wiring Diagrams Ford Motor Co.

PAVLIN

Fig. 13: EACT Control Module, A/C & Heater System (Grid 48-51)
1992 Ford Taurus LX

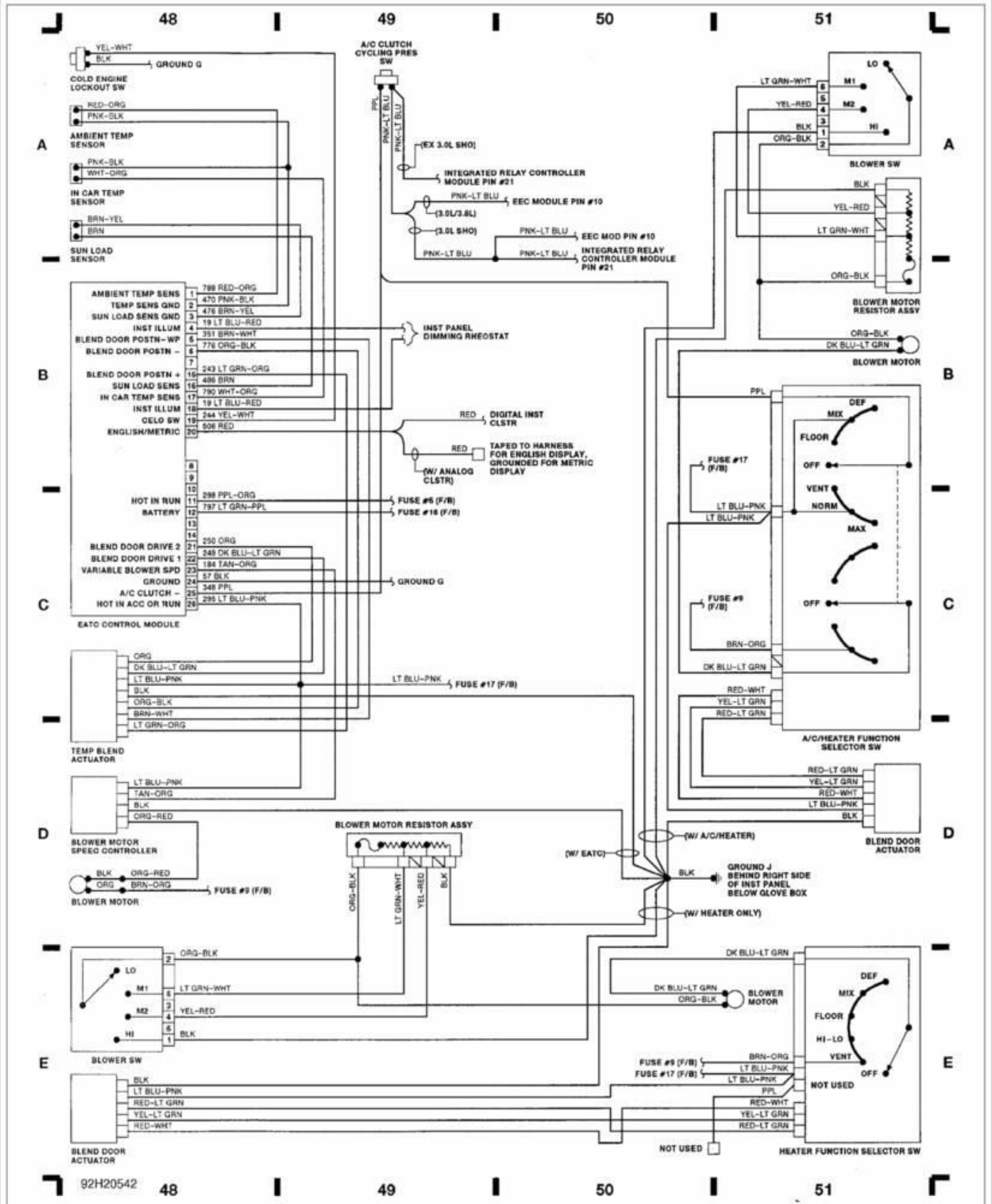

WIRING DIAGRAMS

1991 Wiring Diagrams Ford Motor Co.

PAVLIN

Fig. 14: Air Bag, Gear Select Sw, Warning Chime Mod
(Grid 52-55)
1992 Ford Taurus LX

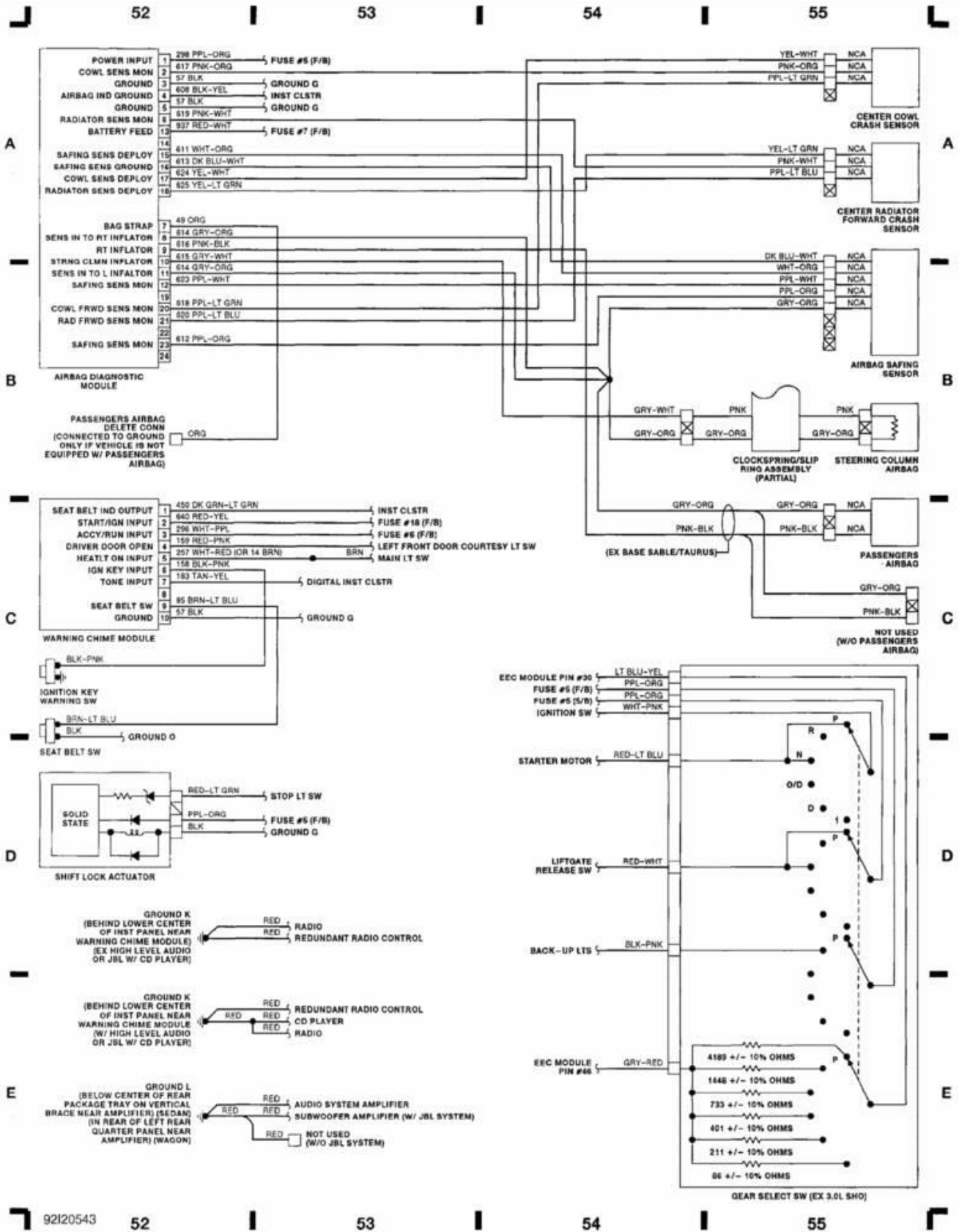

WIRING DIAGRAMS

1991 Wiring Diagrams Ford Motor Co.

PAVLIN

Fig. 15: Multi-Function Sw, Lamp Out Warning Module
(Grid 56-59)
1992 Ford Taurus LX

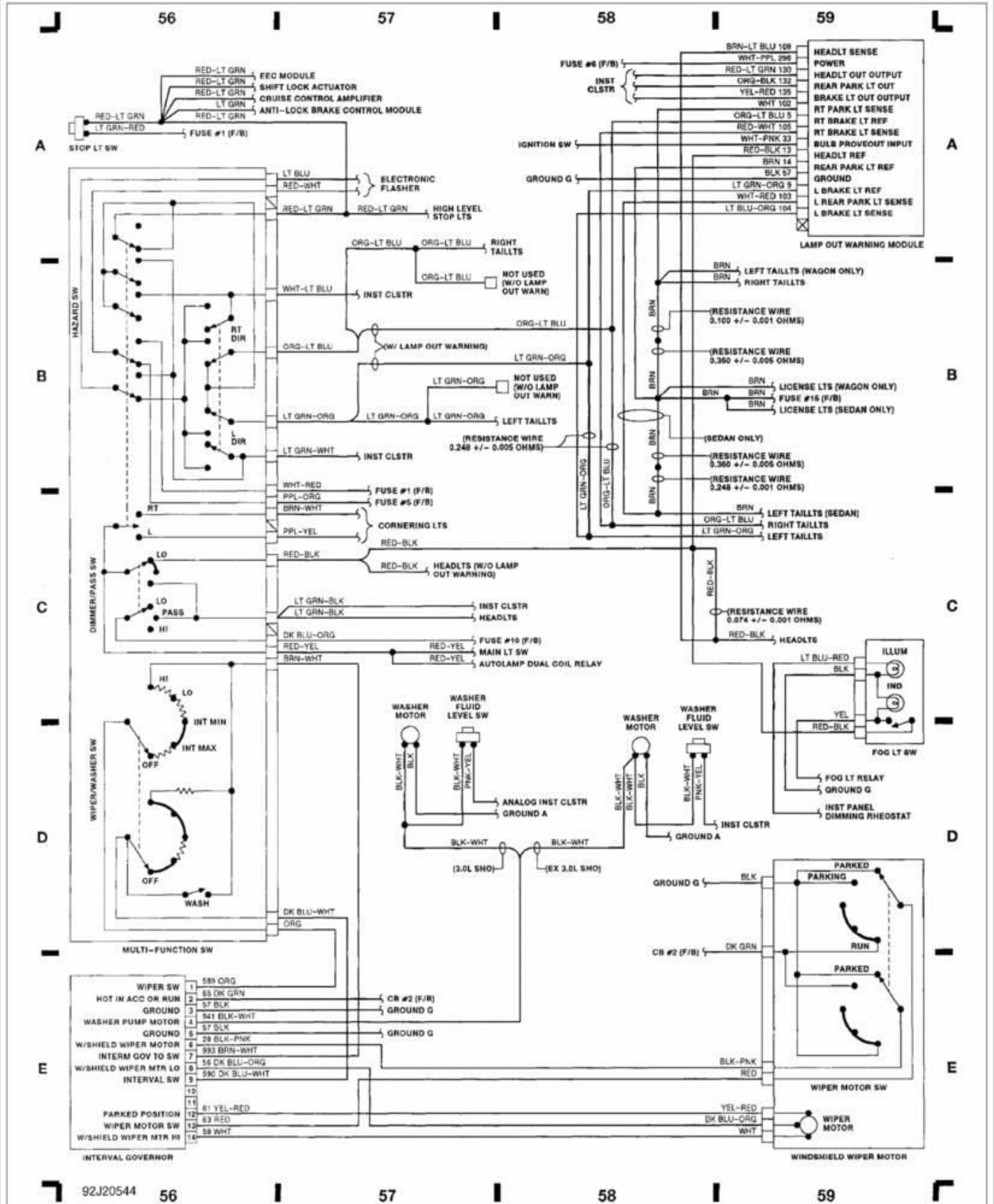

WIRING DIAGRAMS
1991 Wiring Diagrams Ford Motor Co.

PAVLIN

Fig. 16: Main Light Switch, Courtesy Lights (Grid 60-63)
 1992 Ford Taurus LX

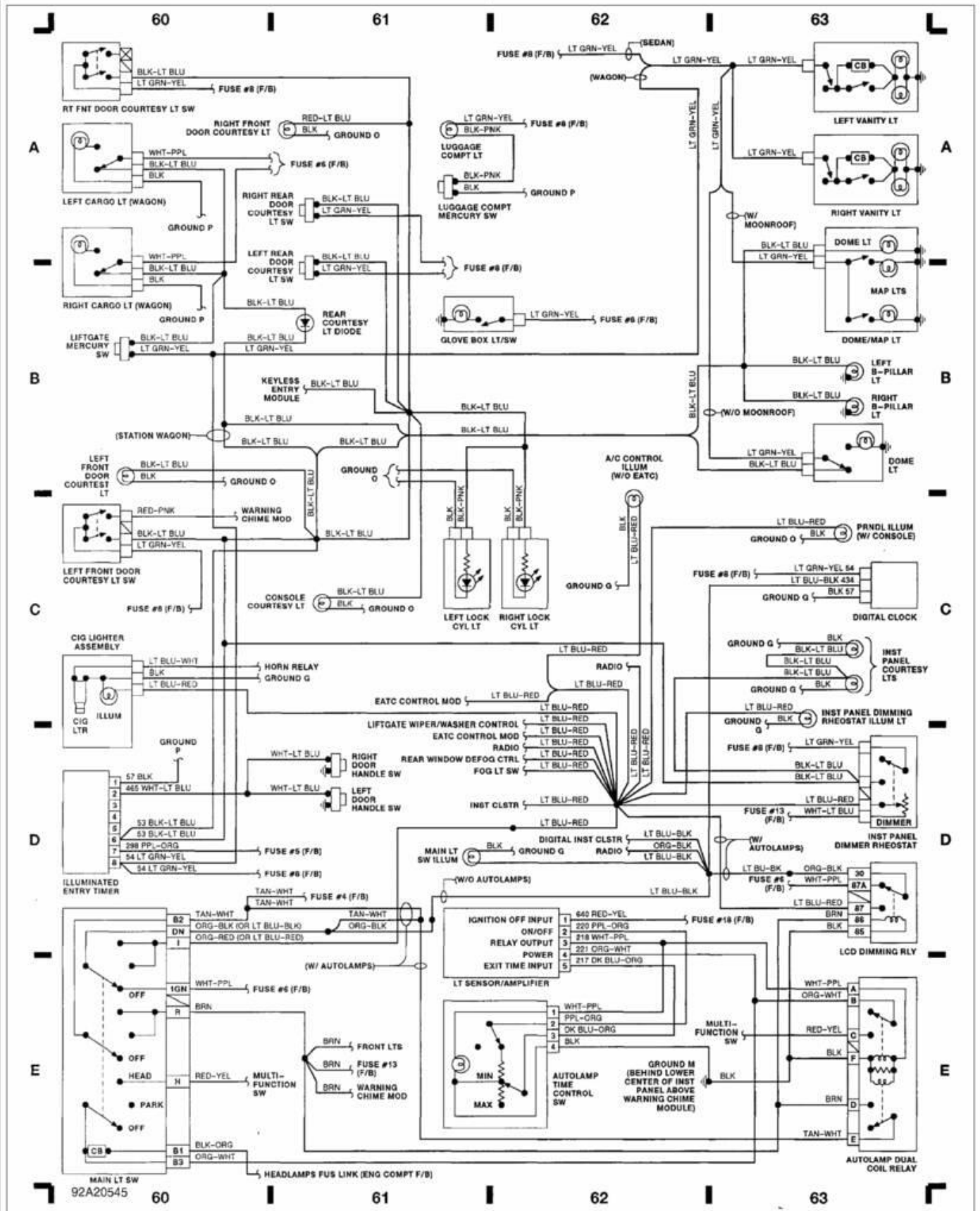

WIRING DIAGRAMS

1991 Wiring Diagrams Ford Motor Co.

PAVLIN

Fig. 17: Analog/SHO & Digital Instrument Panel (Grid 64-67)
1992 Ford Taurus LX

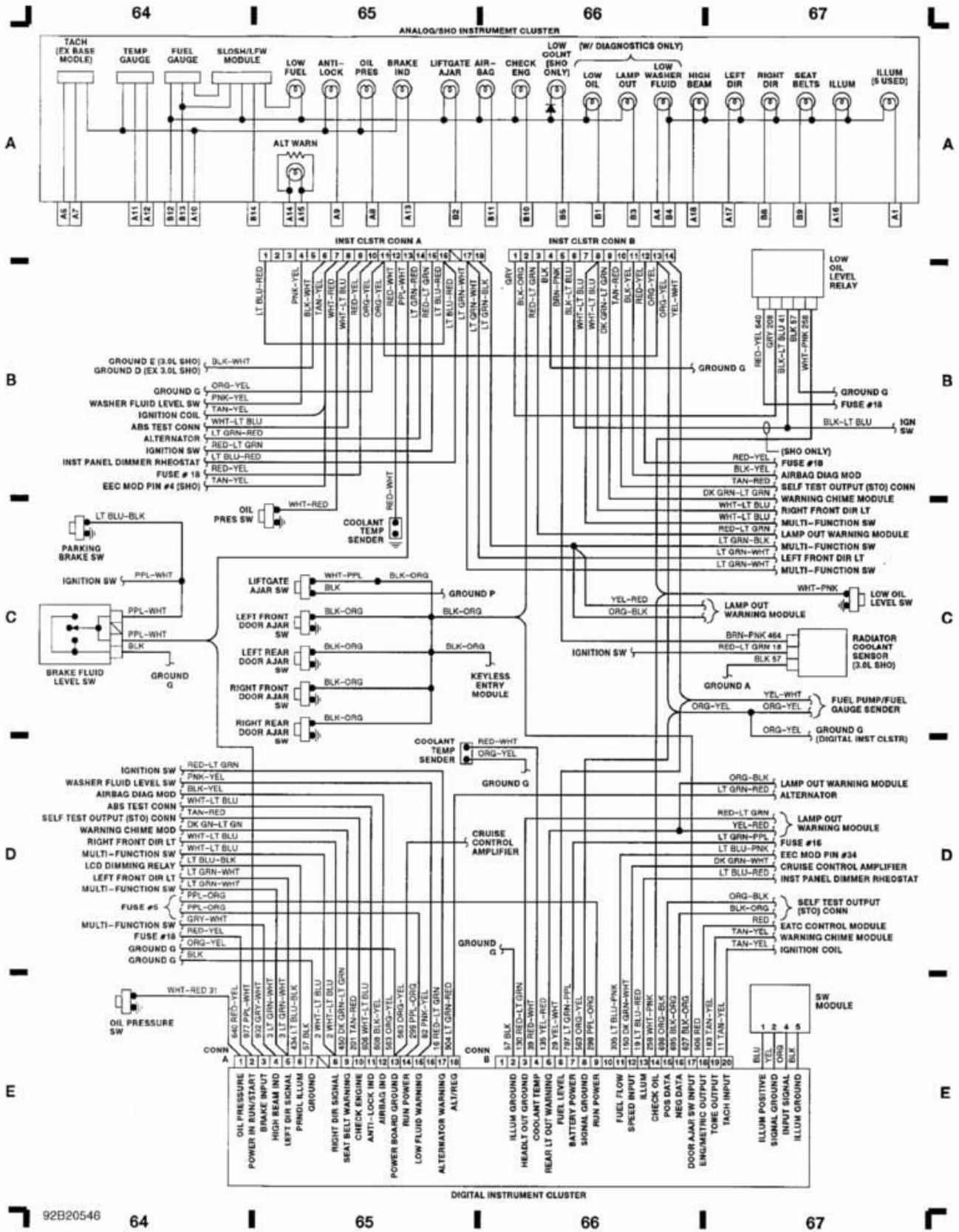

WIRING DIAGRAMS

1991 Wiring Diagrams Ford Motor Co.

PAVLIN

Fig. 18: Power Antenna/Moonroof, Rear Defogger, Liftgate (Grid 68-71)
1992 Ford Taurus LX

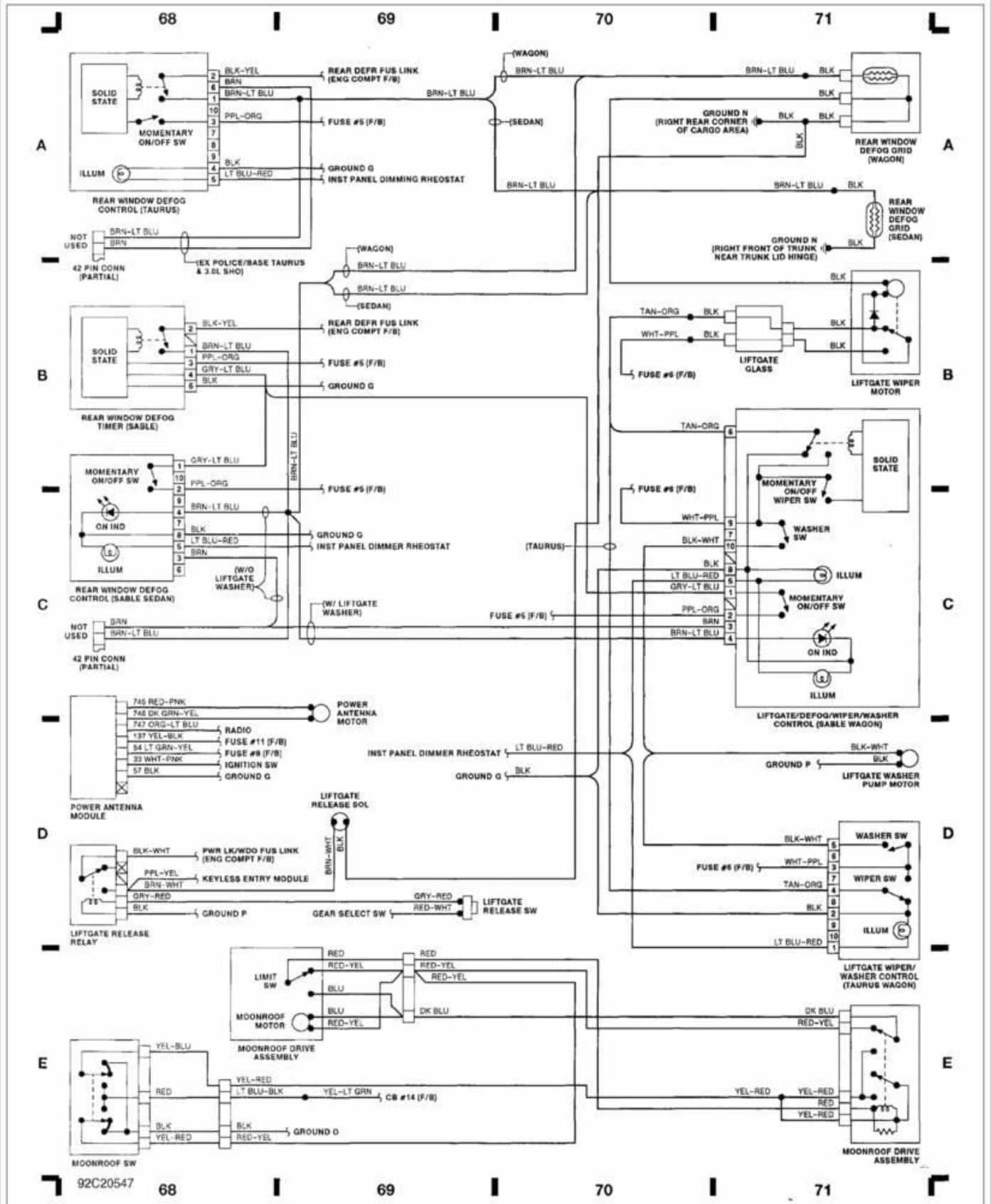

WIRING DIAGRAMS

1991 Wiring Diagrams Ford Motor Co.

PAVLIN

Fig. 19: Pwr Windows/Seats, Pwr Doors W/O Keyless Entry (Grid 72-75)
1992 Ford Taurus LX

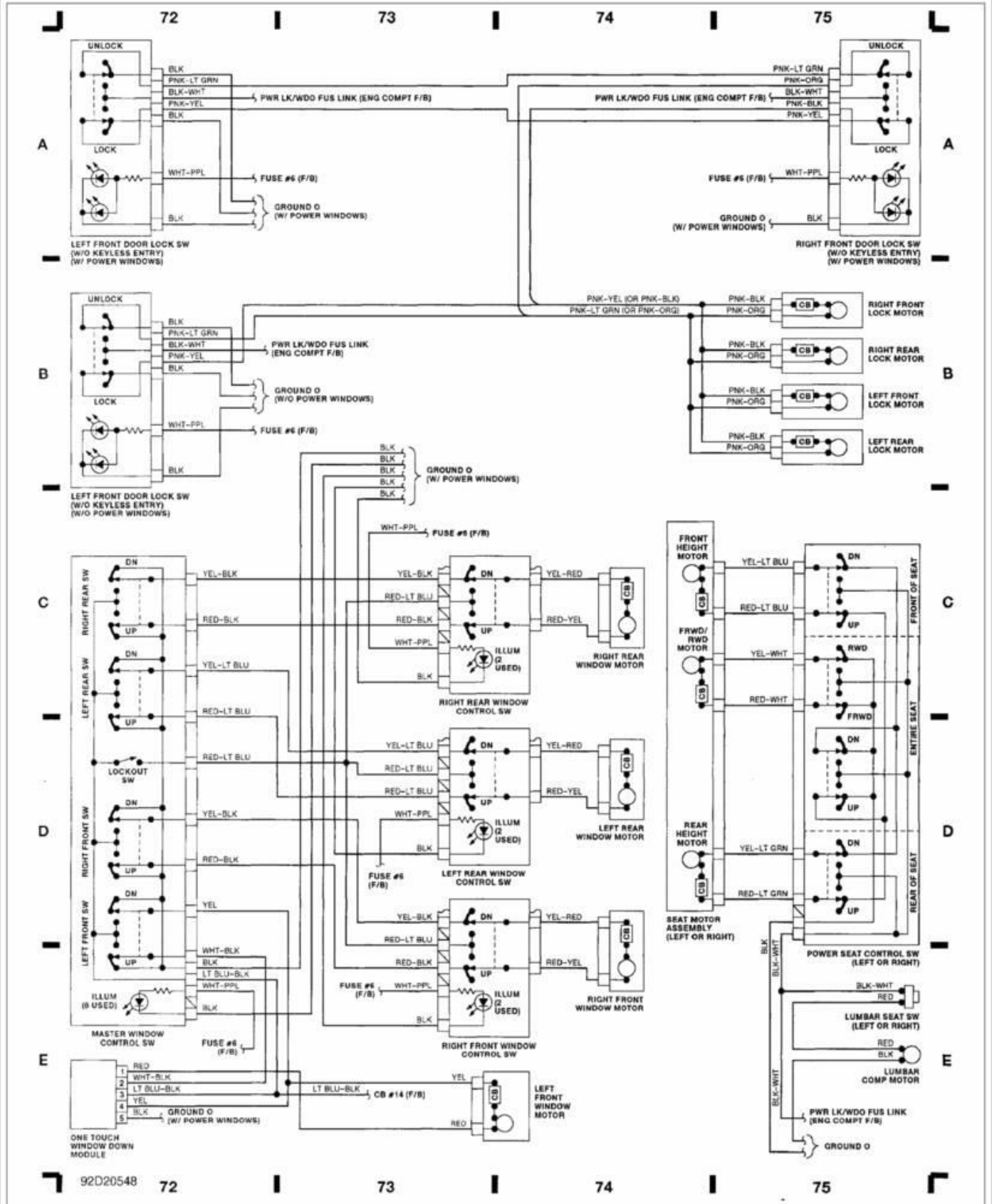

WIRING DIAGRAMS

1991 Wiring Diagrams Ford Motor Co.

PAVLIN

Fig. 20: Power Mirror, Power Doors W/Keyless Entry
 (Grid 76-79)
 1992 Ford Taurus LX

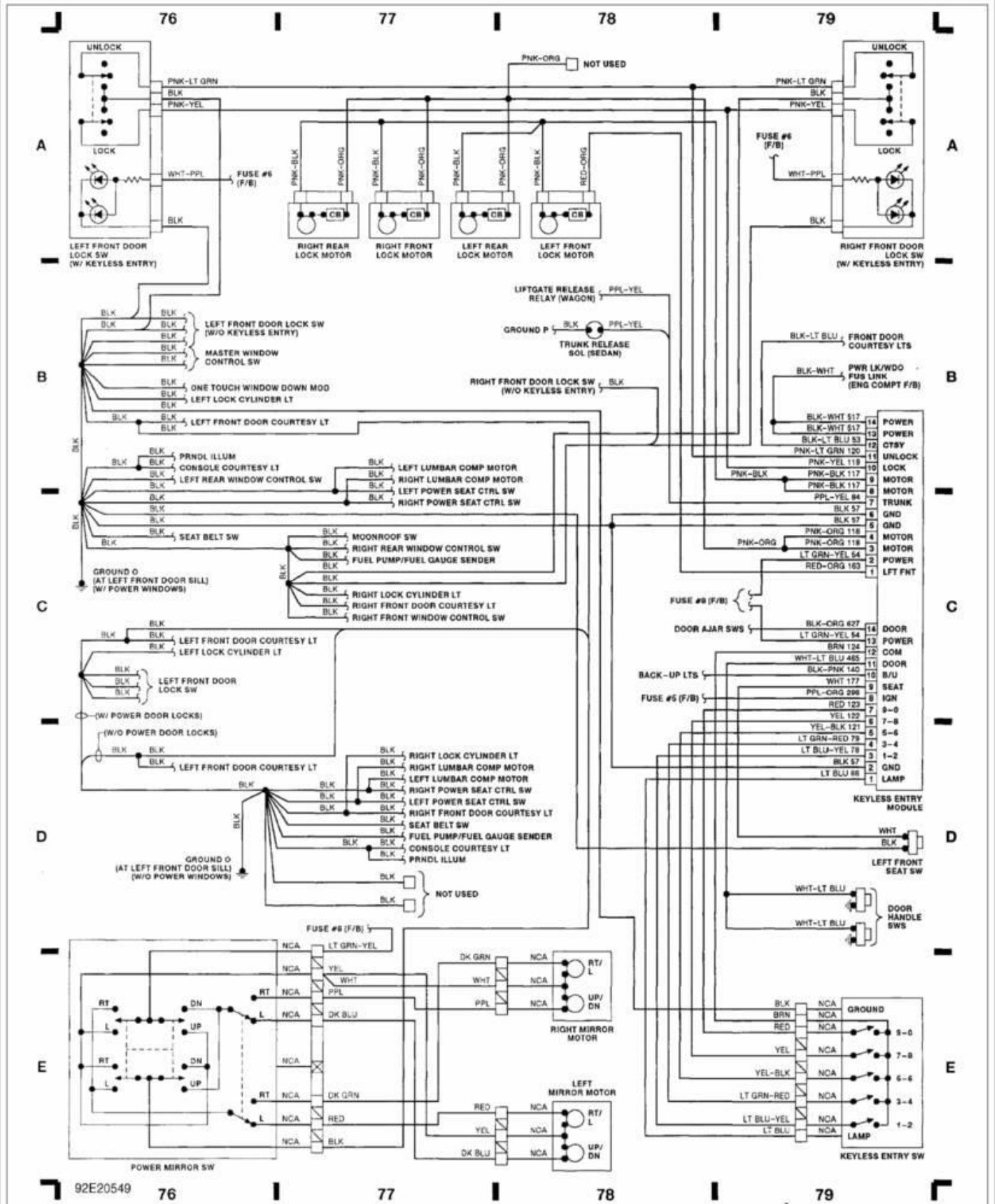

WIRING DIAGRAMS

1991 Wiring Diagrams Ford Motor Co.

PAVLIN

Fig. 21: Taillights (Wagon & Sedan) (Grid 80-83)
1992 Ford Taurus LX

